

Name : _____ ()

Class : Primary 6 _____

CHIJ ST NICHOLAS GIRLS' SCHOOL

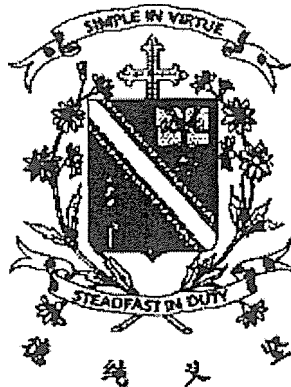

Primary 6

Preliminary Examination

SCIENCE

BOOKLET A

23 August 2023

Total Time for Booklets A and B: 1 hour 45 minutes

**28 questions
56 marks**

**Do not open this booklet until you are told to do so.
Follow all instructions carefully.**

This paper consists of 15 printed pages.

Section A (28 x 2 marks = 56 marks)

For each question from 1 to 28, four options are given. One of them is the correct answer. Make your choice (1, 2, 3 or 4). Shade the correct oval (1, 2, 3 or 4) on the Optical Answer Sheet provided.

1. Study the three organisms shown below.



fern



mushrooms

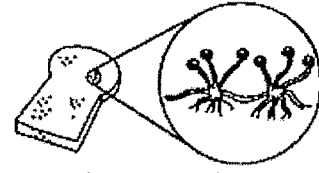

moulds

Which statement (s) is/are correct?

- A They reproduce by spores.
- B They cannot make their own food.
- C They help to decompose dead organisms.

- (1) A only
- (2) C only
- (3) B and C only
- (4) A, B and C

2. The graph shows the change in the amounts of two gases A and B in a garden over a period of time.

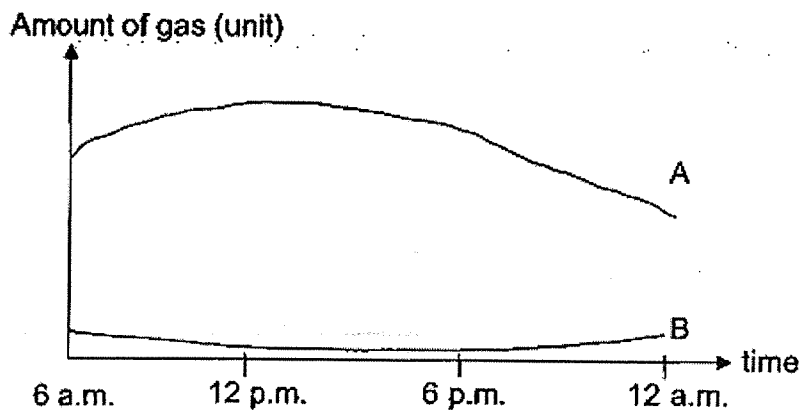

Which of the following identifies the gas and explains the change in the amounts correctly?

	Gas A	Gas B	Process
(1)	oxygen	carbon dioxide	respiration by plants
(2)	nitrogen	oxygen	respiration by plants
(3)	oxygen	carbon dioxide	photosynthesis by plants
(4)	carbon dioxide	oxygen	photosynthesis by plants

3. The diagram below shows two different flowers from the same plant.

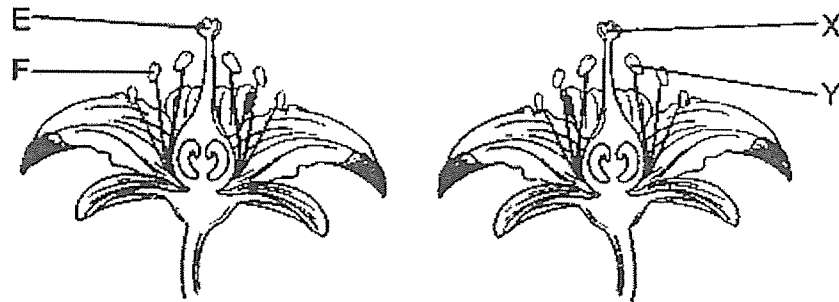

Pollination takes place when pollen grains are transferred from parts _____.

- (1) F to X
 (2) F to Y
 (3) X to E
 (4) X to Y
4. Which of the statements below is true about the reproduction of humans?
- A Many sperms are needed to fertilise one female egg cell.
 B The female egg cell takes more than 1 year to develop into a foetus.
 C For fertilisation to occur, the nucleus of the sperm must fuse with the nucleus of the female egg cell.
 D The developing foetus will have genetic characteristics from both parents.
- (1) A and B only
 (2) A and D only
 (3) B and C only
 (4) C and D only
5. The table below shows some organisms at different places in a garden.

Places where organisms are found	
At or near a pond	At a field
<ul style="list-style-type: none"> • 2 frogs • 4 hydrilla plants • 2 dragonflies • 5 tadpoles • 4 goldfish 	<ul style="list-style-type: none"> • 2 butterflies • 3 caterpillars • 7 bees • 1 tree

Based on the table above, which statement is correct?

- (1) There are 2 habitats and 2 communities in the garden.
 (2) There are 4 populations and 2 communities at the field.
 (3) There are 4 populations and 1 community at or near the pond.
 (4) There are 17 populations in the pond and 13 populations at the field.

6. Shawn caught three organisms X, Y and Z from a pond and placed them in two aquariums A and B. He placed organisms X and Y in aquarium A and organisms X and Z in aquarium B. He then put equal number of plants in each aquarium and left the aquariums near the window.

He counted the number of organisms in the aquariums every week for a month and did not observe any dead organisms in it. His results are shown in the graphs below.

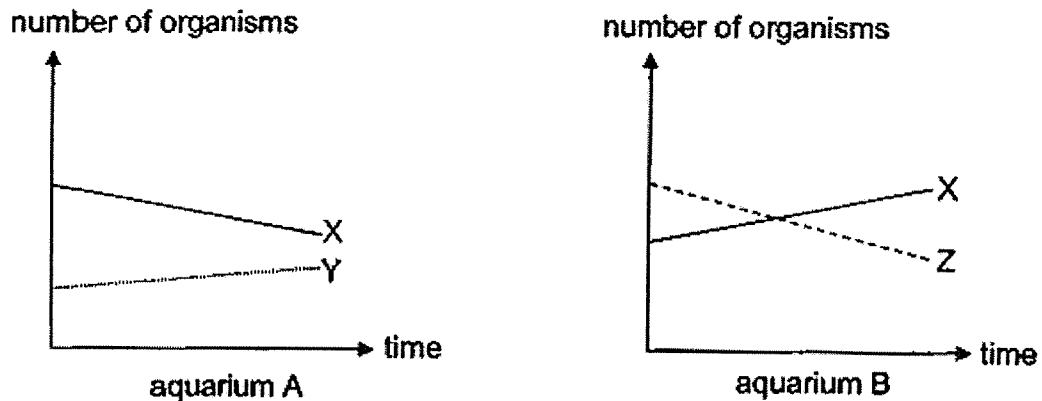

From the graphs above, which of the following shows part of the food chain linking the three organisms?

- (1) $X \rightarrow Y \rightarrow Z$
- (2) $Y \rightarrow X \rightarrow Z$
- (3) $Z \rightarrow X \rightarrow Y$
- (4) $Z \rightarrow Y \rightarrow X$

7. The difference in appearance between leaf A and leaf B is caused by different types of organisms acting on the leaves.

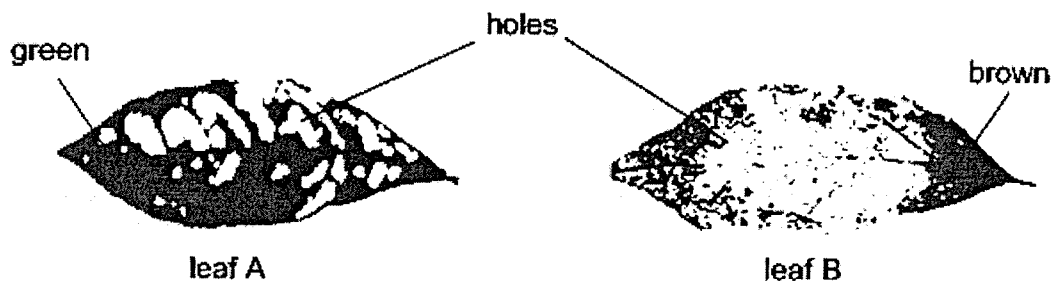

Which of the following shows correctly the type of organism that caused the appearance of leaf A and leaf B?

	Leaf A	Leaf B
(1)	plant eater	plant eater
(2)	plant eater	decomposer
(3)	decomposer	plant eater
(4)	decomposer	decomposer

8. The statements below are about adaptations of some animals.

- A Animal P hunts in groups.
- B Animal Q has thick fur to keep itself warm.
- C Animal R uses breathing tube to breathe in water.
- D Animal S eats a large amount of food before hibernation.

Which of the following shows how the adaptations can be classified?

	Structural adaptation	Behavioural adaptation
(1)	A only	B, C and D
(2)	B only	A, C and D
(3)	A and D	B and C
(4)	B and C	A and D

9. The table below shows 3 organisms grouped according to 2 physical factors M and N that are found in the environment they live in.

Organism	Physical factor M	Physical factor N
Y	High	Low
Algae	High	High
Earthworm	Low	High

Which of the following best represents physical factors M and N and the habitat that organism Y can be most likely found in?

	Physical factor M	Physical factor N	Habitat
(1)	Light	Moisture	Pond
(2)	Light	Moisture	Desert
(3)	Moisture	Light	Pond
(4)	Moisture	Light	Desert

10. Which of the following is a result of global warming?

- (1) Air pollution
- (2) Deforestation
- (3) Burning of fossil fuels
- (4) Floods and droughts

11. Which of the following is a positive impact on the environment when we recycle?

- A It reduces the need to cut down more trees.
- B It reduces the amount of rubbish buried in landfills.
- C It slows down the depletion of our natural resources.

- (1) A only
- (2) A and B only
- (3) B and C only
- (4) A, B and C

12. Study the table below.

Substance	Has a definite shape	Has a definite volume
P	No	Yes
Q	Yes	Yes

Which of the following conclusion is correct?

- (1) Both substance P and Q cannot be compressed.
- (2) Substance P is a liquid while substance Q is a gas.
- (3) Substance P is a solid while substance Q is a liquid.
- (4) Both substance P and Q take the shape of the container.

13. Jane made a ball out of plasticine and put it into a beaker of water. The water level rose from 50 cm^3 to 90 cm^3 .

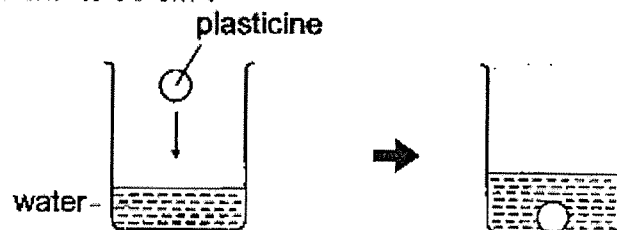

She took the plasticine out and made it into 4 smaller balls. She then placed them into another beaker containing 120 cm^3 of water as shown.

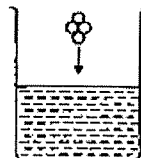

What is the water level after the 4 smaller balls were placed into the beaker of water?

- (1) 120 cm^3
- (2) 124 cm^3
- (3) 140 cm^3
- (4) 160 cm^3

14. Two similar solids are dropped slowly into a container with 3 openings as shown below.

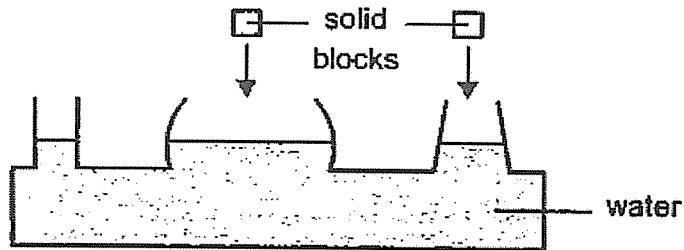

Which of the following shows the correct water level in the container after the solids were dropped into the container?

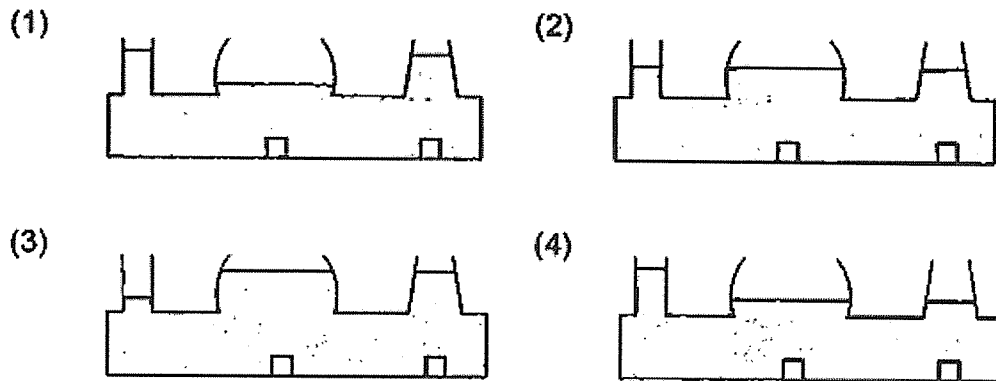

15. The diagram below shows a protective suit worn by firefighters when they are at work.

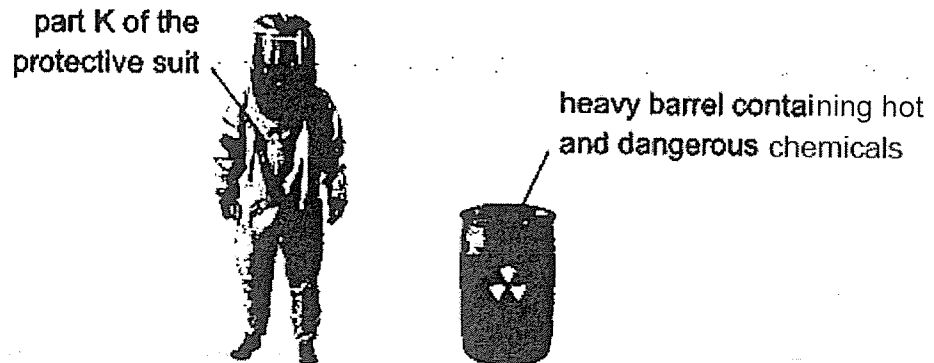

Based on the properties shown below, which material W, X, Y or Z is the most suitable for making part K of the suit above?

	Material	Property		
		Flexible	Waterproof	Heat Conductivity
(1)	W	no	yes	poor
(2)	X	yes	yes	good
(3)	Y	yes	yes	poor
(4)	Z	yes	no	good

16. Ali conducted an experiment on 2 bags, each made of a different material P and Q. He placed 5 kg of books into each bag and lifted them above the ground as shown below.

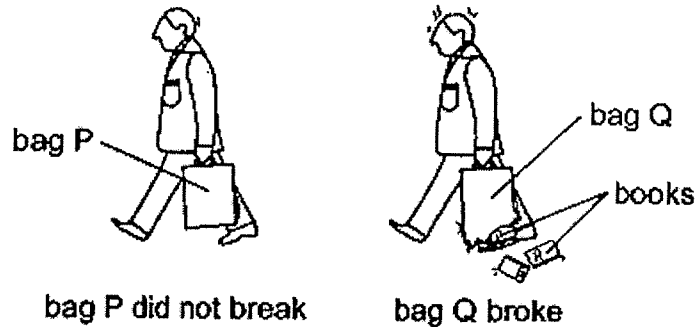

Based on the above results, which of the following is true about the bags?

- (1) P is heavier than Q.
 - (2) P is stronger than Q.
 - (3) P is less flexible than Q.
 - (4) P is less absorbent than Q.
17. Which of the following diagrams correctly shows how light rays enter the person's eyes to enable him to see the book?

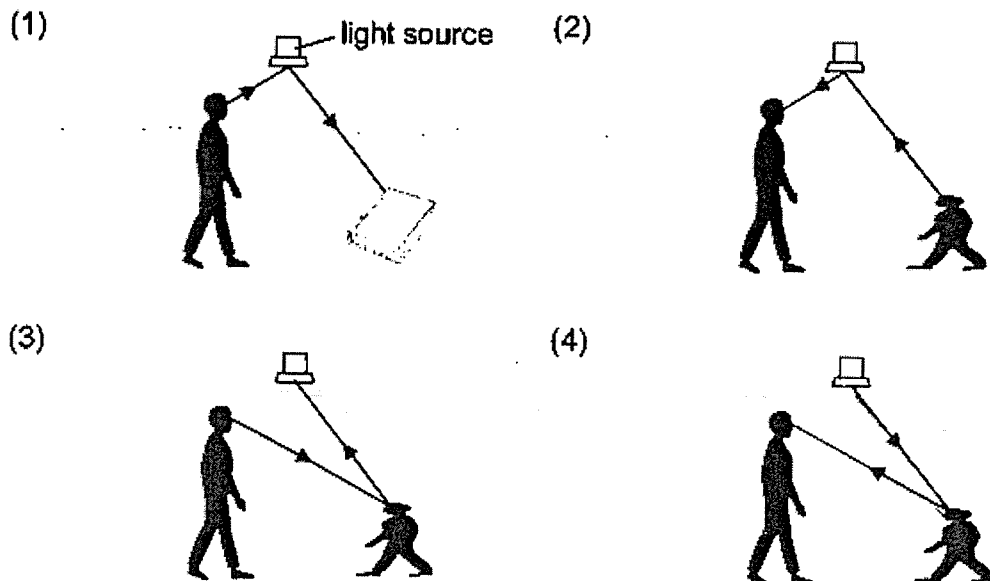

18. The diagram below shows the layout of the stage for a shadow performance.

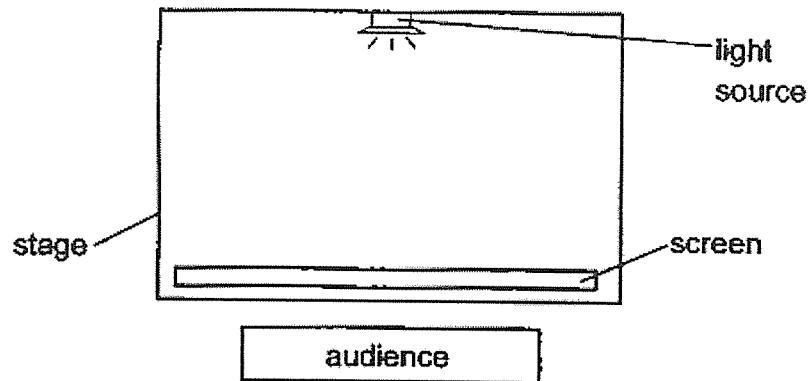

There were 3 actors E, F and G who were of the same height. The audience saw the shadows of the actors on the screen as shown.

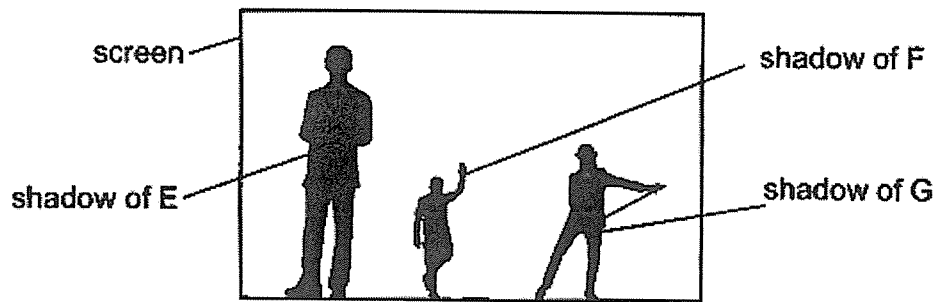

Which of the following shows the positions of actors E, F and G?

(1)

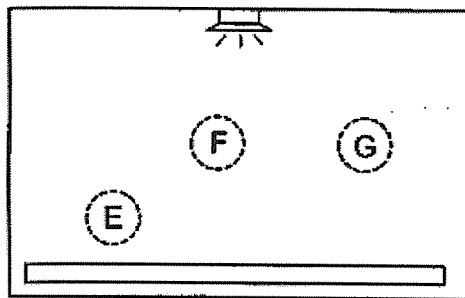

(2)

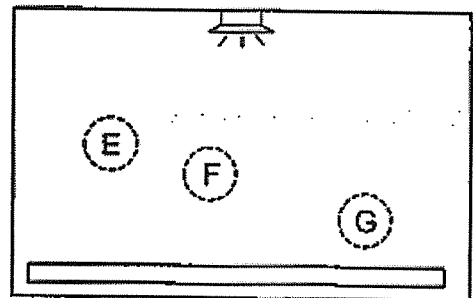

(3)

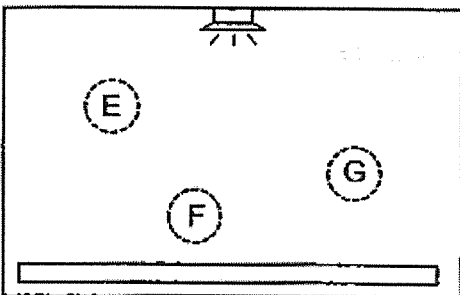

(4)

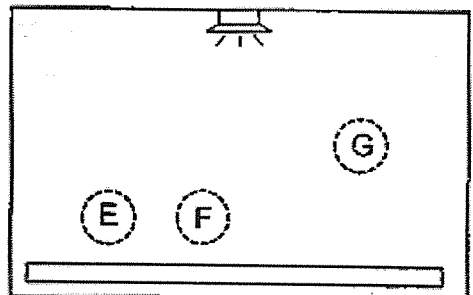

19. Han Wei built a machine to separate different items based on a certain property of material. A mixture of items made of different materials was poured onto a conveyor belt A. A magnet placed in conveyor belt B would attract some of the items and drop them into bin D as it moves. Belt A would then move the remaining items to be collected in bin C.

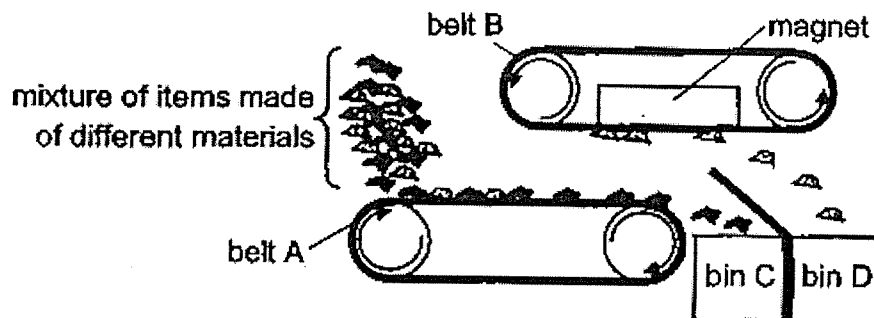

Based on the results, which of the following could have been collected in bins C and D?

	items collected in bin C	items collected in bin D
(1)	plastic chips	steel nails
(2)	copper nails	glass beads
(3)	steel nails	iron nails
(4)	glass beads	copper nails

20. The diagram below shows some identical thumbtacks A, B, C and D attached to a metal frame with equal amount of wax.

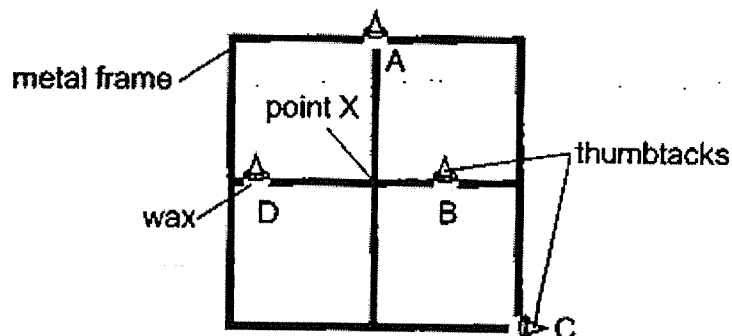

Point X on the metal frame was heated with a strong flame for 15 minutes.

Which of the following shows the correct order in which the thumbtacks would fall off from the metal frame?

	first to drop			last to drop
(1)	A	B	C	D
(2)	A	D	B	C
(3)	B	C	D	A
(4)	B	D	A	C

21. Fauzi could not open the metal container below as the lid was too tight.

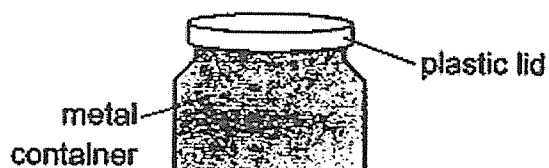

Which of the following actions will allow him to open the container more easily?

- (1) Heat the plastic lid over a strong flame.
 - (2) Heat the metal container over a strong flame.
 - (3) Place some ice cubes on the top part of the plastic lid.
 - (4) Place some ice cubes around the sides of the metal container.
22. The table below shows the state of matter of 4 substances E, F, G and H at 18 °C and 82 °C.

Substance	State of matter of the substance	
	at 18 °C	at 82 °C
E	solid	solid
F	solid	liquid
G	liquid	liquid
H	liquid	gas

Which of the substances E, F, G or H will most likely have a melting point of 10 °C and a boiling point of 95 °C?

- (1) E
- (2) F
- (3) G
- (4) H

23. Raju conducted an experiment to find out if different weather conditions affects the rate of evaporation of water. He soaked 3 identical towels X, Y and Z in equal amounts of water before hanging them to dry under different conditions as shown below.

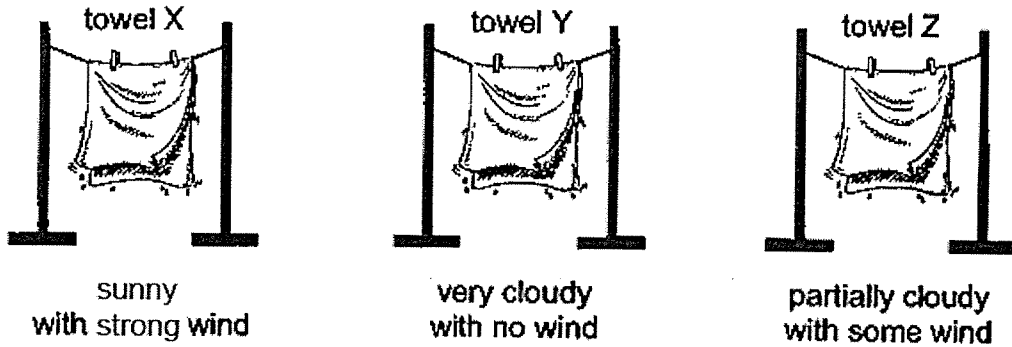

Which of the following graphs shows the change in the mass of the wet towels over a period of time?

(1)

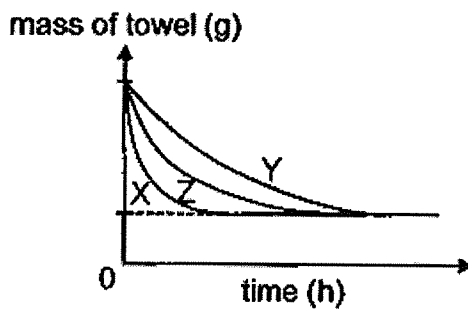

(2)

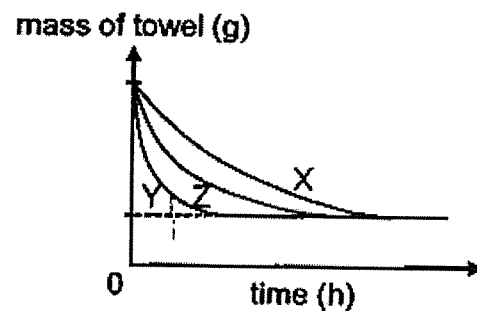

(3)

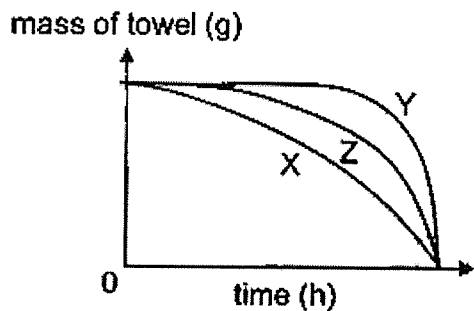

(4)

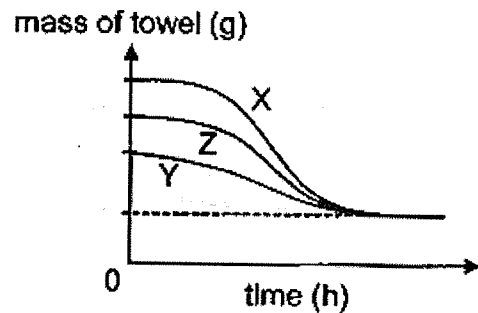

24. Nan Xing set up 4 different circuits using identical bulbs and batteries as shown below. All electrical components used are in good working condition.

In which of the circuits below will bulb T be the brightest

(1)

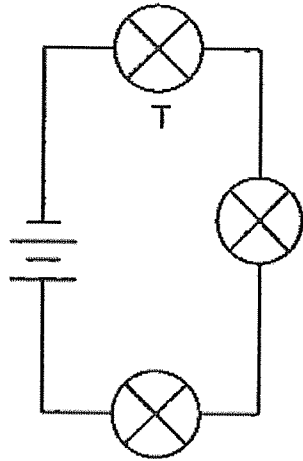

(2)

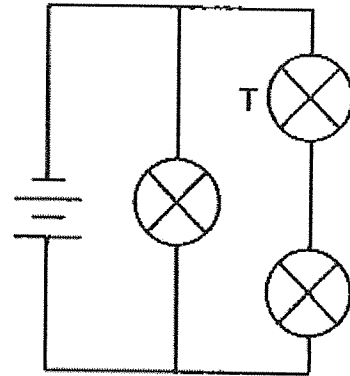

(3)

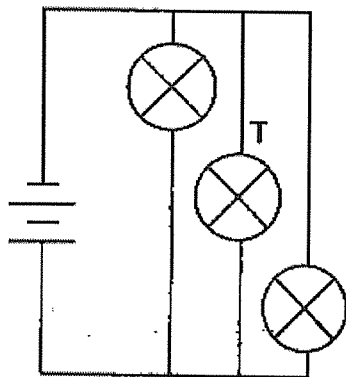

(4)

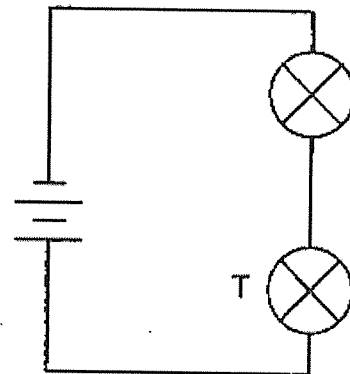

25. Which of the following are renewable sources of energy?

- A oil
- B solar
- C natural gas
- D running water

- (1) A and C only
- (2) A and D only
- (3) B and C only
- (4) B and D only

26. The diagram below shows 4 steel cubes A, B, C and D, each of the same volume. Cubes A and C are placed on a wooden support while cubes B and D are hung from a ceiling.

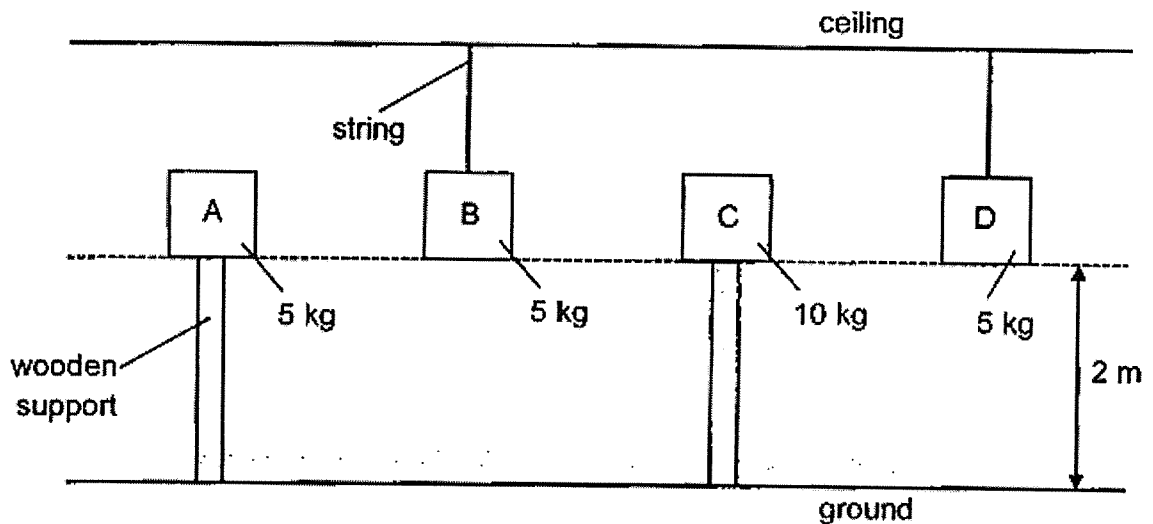

Which of the following statements is true about the amount of gravitational potential energy possessed by the cubes above?

- (1) Cube B has less gravitational potential energy than cube D.
- (2) Cube A has more gravitational potential energy than cube C.
- (3) Cube A has the same amount of gravitational potential energy as cube B.
- (4) Cube C has the same amount of gravitational potential energy as cube D.

27. The diagram below shows the movement of a gymnast as she runs towards a jump board from A to D.

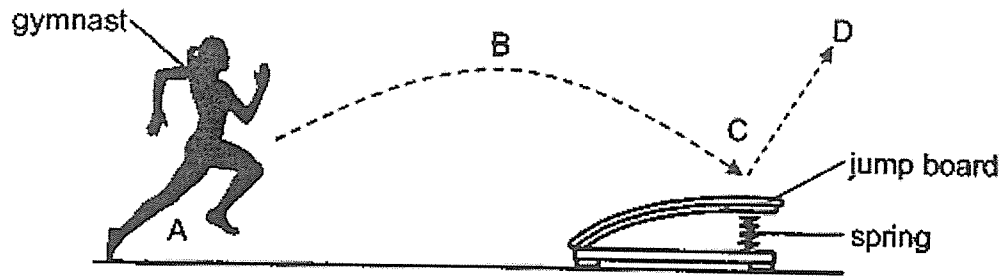

Which of the following correctly identifies the forces acting on her as she moves from B to C to D?

	Downward force at B	Upward force at C
(1)	gravitational force	frictional force
(2)	gravitational force	elastic spring force
(3)	frictional force	elastic spring force
(4)	elastic spring force	gravitational force

28. Ron conducted an experiment using the set-up below.

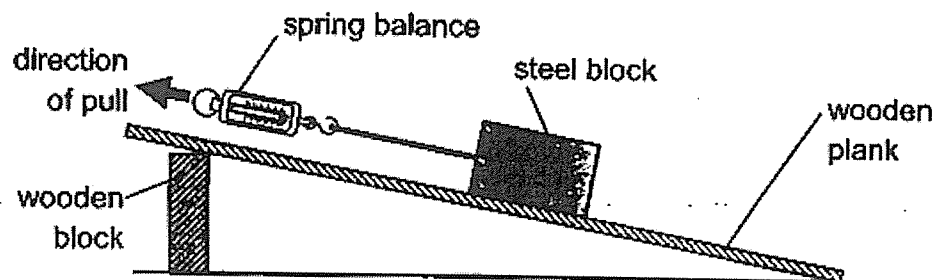

He pulled the steel block up the wooden plank using a spring balance with a constant force. The reading on the spring balance showed 20 units.

Which of the following action(s) will allow him to decrease the reading on the spring balance?

- A Wrap the steel block with sandpaper.
 - B Place a magnet under the steel block.
 - C Apply some oil onto the surface of the wooden plank.
- (1) A only
 (2) C only
 (3) A and B only
 (4) B and C only

END OF BOOKLET A

Name : _____ ()

Class : Primary 6 _____

CHIJ ST NICHOLAS GIRLS' SCHOOL

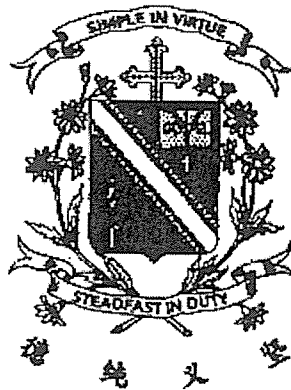

Primary 6

Preliminary Examination

SCIENCE

BOOKLET B

23 August 2023

Total Time for Booklets A and B: 1 hour 45 minutes

**13 questions
44 marks**

**Do not open this booklet until you are told to do so.
Follow all Instructions carefully.
Answer all questions.**

This booklet consists of 15 printed pages.

Booklet A	56
Booklet B	44
Total	100

Parent's Signature/Date

Section B (44 marks)

For questions 29 to 41, write your answers in this booklet. The number of marks available is shown in the brackets at the end of each question or part question.

29. Farinah conducted an experiment using the set-up shown below.

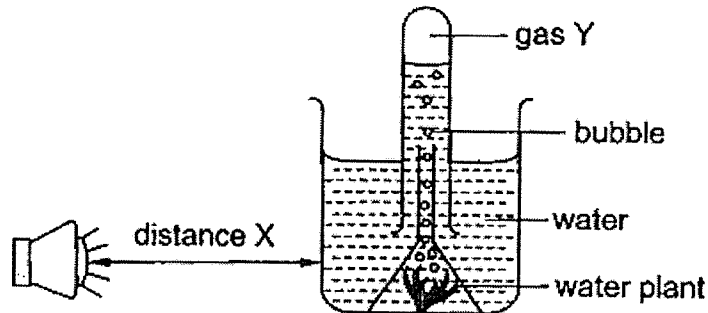

Farinah placed a lamp at different distances from her set-up and counted the number of bubbles produced per minute. She recorded her results of the experiment in the table below.

Distance X (cm)	Number of bubbles per minute
5	30
10	29
15	25
20	20
25	15

(a) State the hypothesis of Farinah's experiment. [1]

(b) Identify gas Y. [1]

(c) Explain how the number of bubbles produced is affected by the distance of the lamp from the water plant. [2]

(d) What changes can be made to the above set-up if Farinah wanted to find out how the amount of carbon dioxide affects the number of bubbles produced? [1]

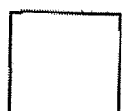

30. Geralyn collected some water samples X, Y and Z from different parts of a river. She placed an orange-coloured block at the bottom of the container and poured in water sample X. She stopped pouring when she cannot see the block and recorded the height of the water h as shown below.

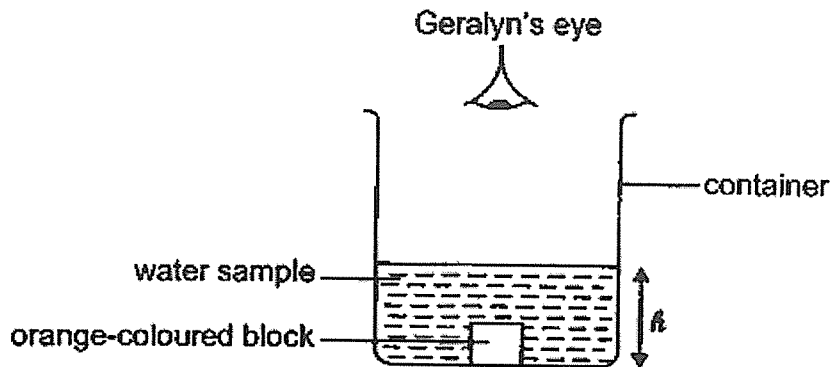

Geralyn then repeated the experiment with water samples Y and Z.

Water sample	X	Y	Z
Height, h (cm)	11	2	6

- (a) Which water sample X, Y or Z will be least suitable for aquatic plants to grow? Explain your answer. [2]

The diagram below shows the different parts of the river where the water samples X, Y and Z were collected.

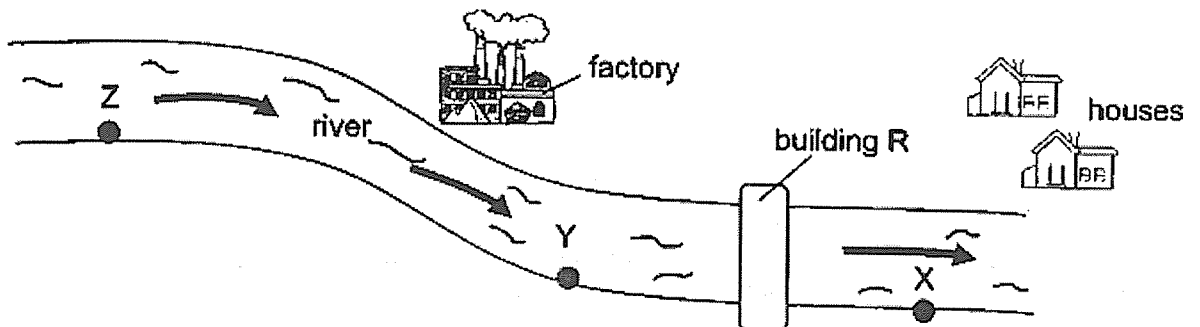

- (b) Based on the results of the experiment, what could building R be? State a reason for your answer. [1]



31. Study the food web below.

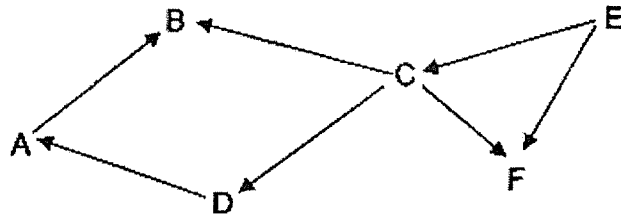

- (a) Based on the food web above, which organism(s) is/are food producers? [1]
Explain your answer.

Some organism X is introduced into the habitat. They prey on organisms F and D.

- (b) How will the population of organism C be affected after some time? [1]
Explain your answer.



32. Fruit A is a special fruit which contains numerous male and female flowers inside the fruit. It emits a unique odour when it is ready for pollination. This odour will attract insect X to go into fruit A through a tiny hole to lay its eggs inside. As insect X enters fruit A, some pollen grains on insect X's body will pollinate the female flowers.

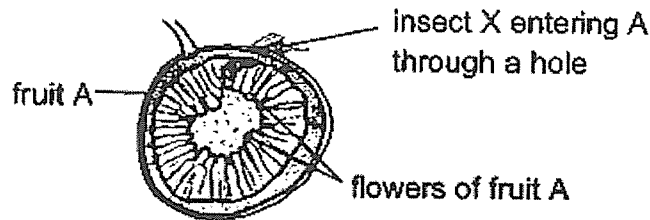

- (a) How does this interaction between fruit A and insect X benefit each other? [2]

(i) Benefit for fruit A: _____

(ii) Benefit for Insect X: _____

The tiny hole which insect X enters is usually small enough for it to enter only.



- (b) How is this tiny hole an advantage for insect X? [1]

The female insect X dies in fruit A after laying her eggs. Fruit A will produce a substance which will cause insect A's body to be disintegrated to become nutrients.

- (c) Give a reason how this is an advantage for the young of fruit A. [1]

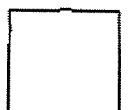

33. Raymond conducted an experiment using the set-up below. Each ball had an identical plastic body but was attached with a different number of plastic hooks. He made 10 copies of each type of ball.

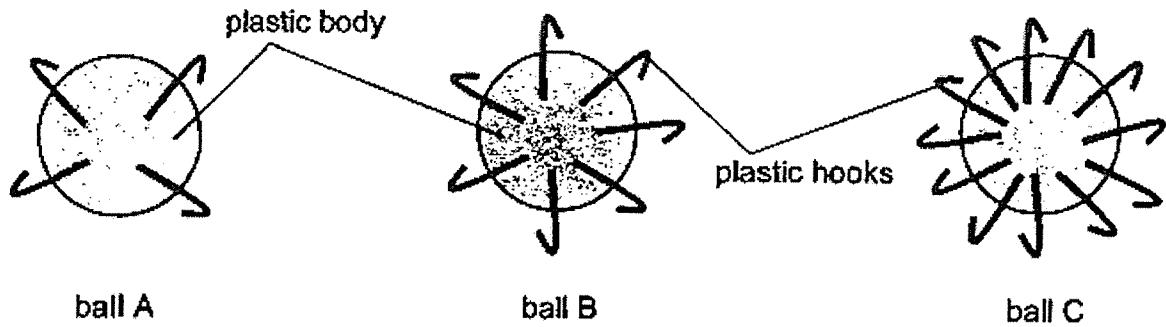

He threw each type of balls into 3 separate similar containers whose inner surfaces are covered with similar furry cloths. He then shook the containers before opening them to count the number of balls that were stuck on the cloths.

The results are recorded in the table below.

Type of Ball	Number of hooks on each ball	Number of balls used	Number of balls found stuck to the cloth
A	4	10	3
B	7	10	5
C	12	10	9

- (a) State the aim of the experiment. [1]

- (b) Based on the results, what can be concluded about the number of hooks on each type of ball and the number of balls stuck to the cloth at the end of the experiment? [1]

- (c) How can the results of the experiment be made more reliable? [1]

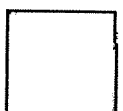

The diagram below shows how the fruits of plant H and J are dispersed.

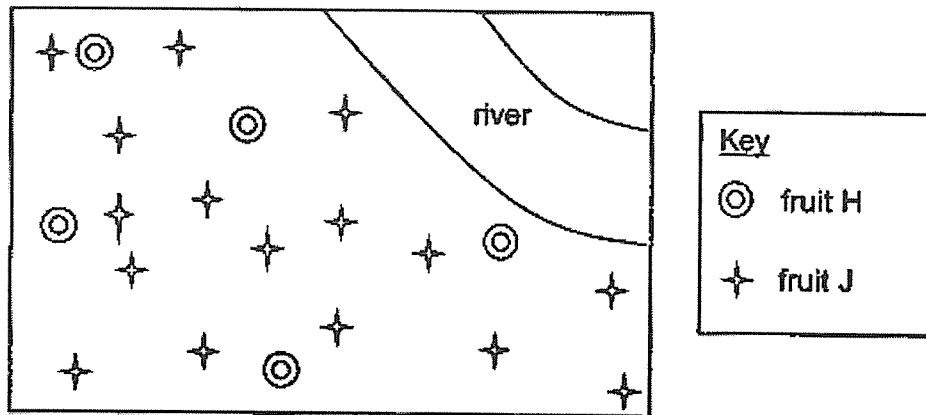

(d) Based on the physical characteristics of the two fruits shown below, which one is most likely to be the fruit of plant J? Put a tick (✓) in the appropriate box below.

[1]

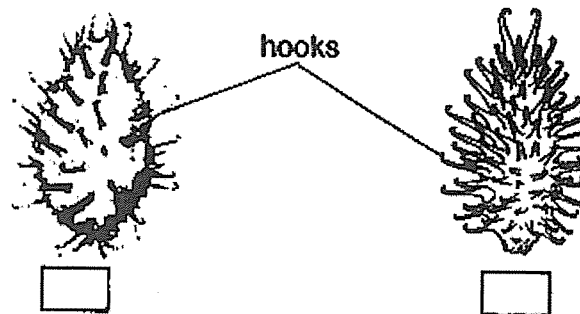

(e) Explain for your choice in (d).

[1]

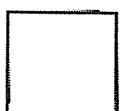

34. Study the set-up below.

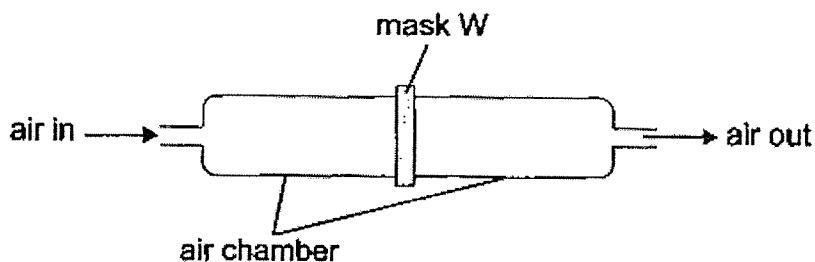

Air was pumped into the air chamber for 10 minutes before mask W was removed to observe the amount of particles on it. Mask W was then replaced with mask X, Y and Z and the experiment was repeated for each mask. The results are as shown below.

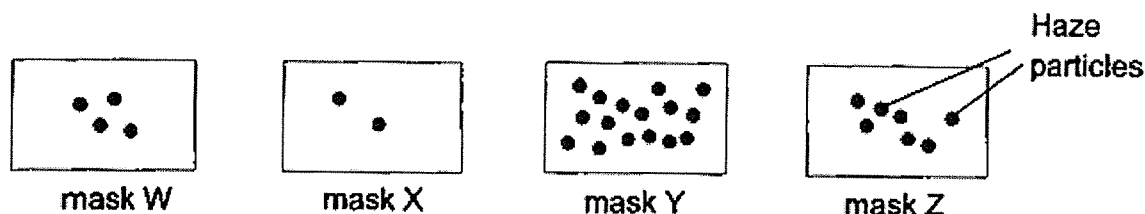

(a) Based on the results, which mask W, X, Y or Z is most suitable to be used during the haze season? State a reason for your answer. [1]

(b) Other than the size of the mask, state one other variable that must be kept constant in order for the experiment to be fair. [1]

(c) State one action of man that can cause haze. [1]



35. Shaoguang conducted an experiment in a dark room using the set-up below. The light sensor detects a reading of 50 units when Material P was placed at position X.

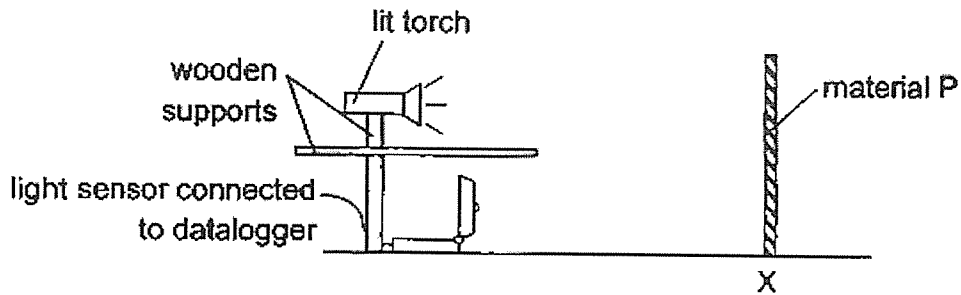

He repeated the experiment using materials Q and R and recorded his results in the table below.

Material	Amount of light detected (units)
P	50
Q	250
R	100

- (a) Based on the results, arrange materials P, Q and R according to the transparency of the materials. [1]

Greatest transparency	→	Least transparency

- (b) The diagram below shows a high visibility vest worn by traffic police officers when they go out patrolling at night. These vests have highly reflective stripes sewn on them as shown by part Z below.

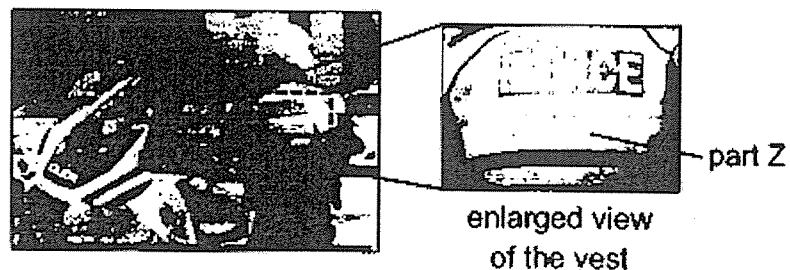

The reflective stripes keep the police officers safe while they are on duty at night. Which material P, Q or R should be used to make part Z of the vest above? Explain your answer. [2]

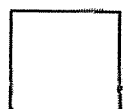

36. Henry placed 3 ring magnets through a wooden support. The North and South poles of ring magnet E are as shown below.

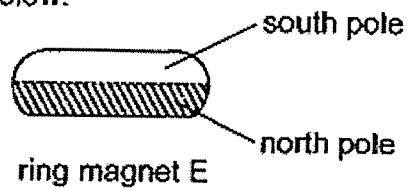

- (a) In the diagram below, shade only the north poles of ring magnets F and G based on the given set-up. [1]

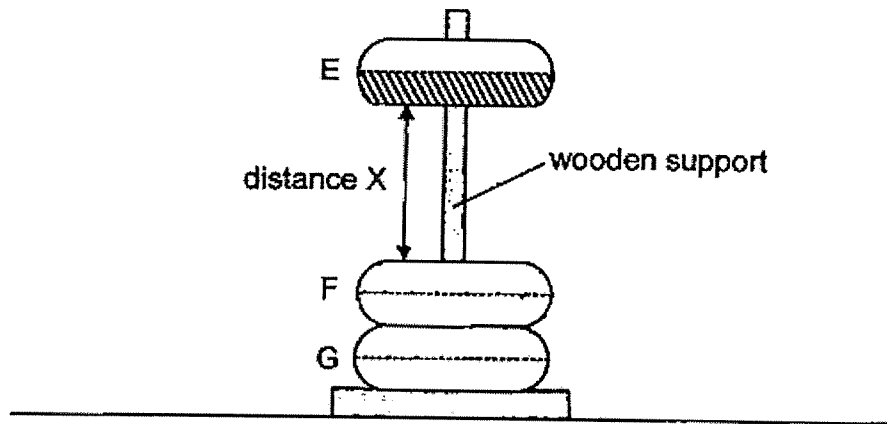

- (b) State a property of magnet that allows the observation between ring magnets F and G to occur. [1]

- (c) Without pushing magnet E, what can Henry do to magnet E to reduce distance X as shown in the diagram above? Explain your answer. [1]



37. Toby conducted an experiment to find out if the amount of trapped air affects the time taken to completely melt a ball of wax. In the set-up below, he placed a ball of 100 g of wax into a double-walled container A with 200 cm³ of trapped air. The container was then placed on a heating plate and the time taken for the wax to melt completely was measured.

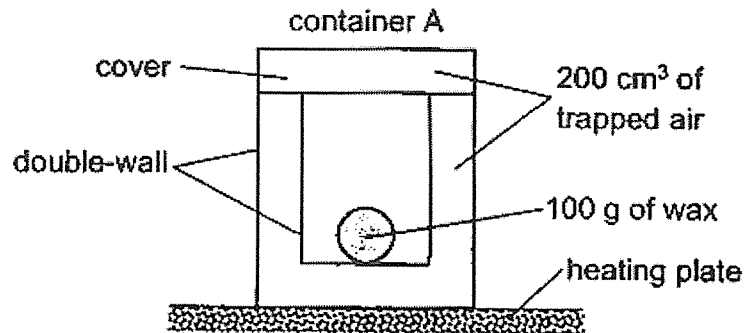

He then repeated the experiment with containers B and C of the same size. Containers B and C are made of identical materials but contain different amounts of trapped air. The results are recorded in the table below.

Container	Mass of wax (g)	Amount of trapped air (cm ³)	Time taken for wax to melt completely (s)
A	100	200	60
B	100	400	150
C	100	700	300

- (a) Is the experiment fair? Explain your answer. [1]

- (b) Based on the results, what is the relationship between the amount of trapped air and the time taken for the wax to be melted amount? [1]

- (c) A delivery rider wanted to deliver cooked food to a customer's house. Which container A, B or C should be used to deliver the cooked food such that the food remains the warmest? Explain your answer. [2]



38. (a) What is freezing?

[1]

Sarah placed a tub of yoghurt from the freezer on a table. After a short time, a thin layer of white solid was formed on the surfaces of the tub.

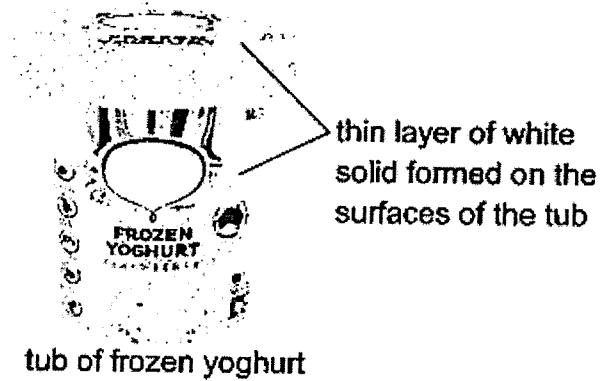

(b) Explain how the white solid was formed.

[2]

(c) What can she expect to observe on the table at the base of the tub after 5 minutes? Explain your answer.

[1]



39. An experiment was conducted using the 3 circuits below. Identical batteries, wires and bulbs were used and all electrical components were in good working condition.

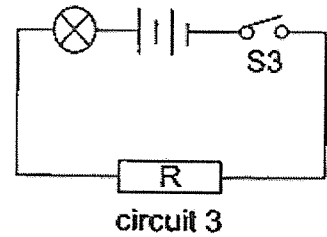
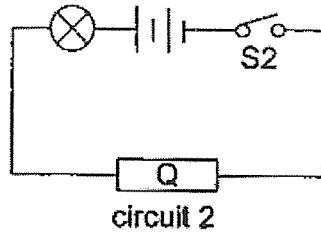
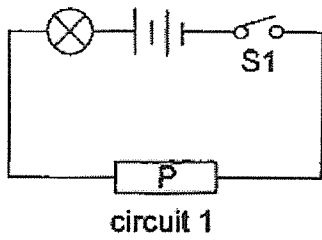

S1, S2 and S3 were then closed and the results were recorded in the table below.

Circuit	Did the bulb light up?
1	yes
2	yes
3	no

Larry then connected materials P, Q and R into circuit 4 as shown below.

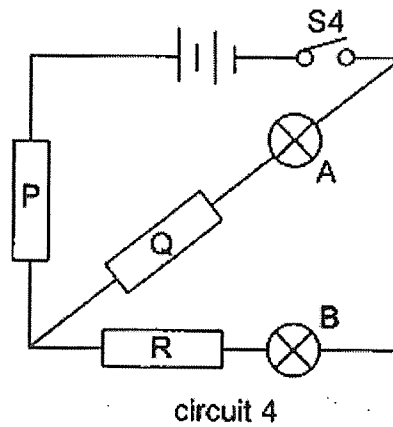

Which bulb A or B will light up when S4 is closed? Explain your answer. [2]

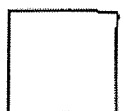

40. At a construction site, a crane with a heavy metal ball is used to demolish large brick or concrete walls. To demolish a wall, the crane pulls the metal ball backwards to position A and then releases it to hit the wall as shown below.

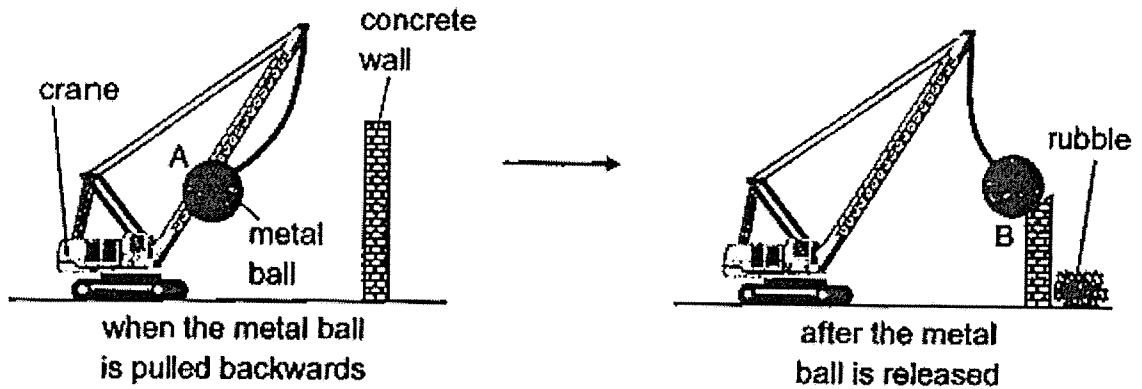

- (a) State the main energy changes that take place in the above observation. [1]

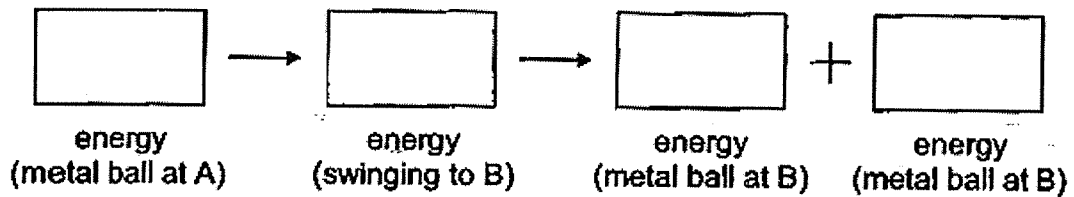

- (b) Without swinging the metal ball higher or faster, state one change to the metal ball that will enable the wall to be demolished faster. Explain your answer in terms of energy conversion. [2]



41. The diagrams below show how a wooden peg containing a metal spring is used to hold up items on a clothesline. The grips of the wooden peg can be opened by squeezing the handles firmly. A photo was held up on a clothesline by first squeezing and then releasing the handles.

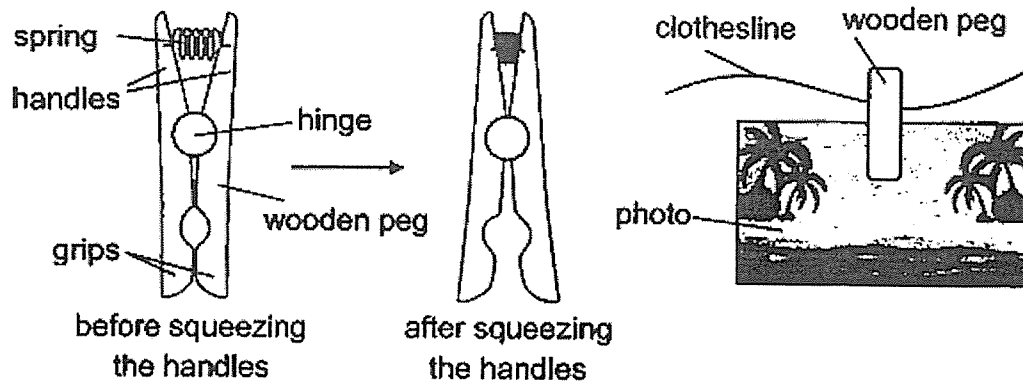

- (a) State the force that enables the photo to be held up by the wooden peg. [1]

An experiment was conducted to investigate the effects of forces on two springs E and F, each of original length 15 cm. A 200-g load was hung on each spring and their new lengths were then measured.

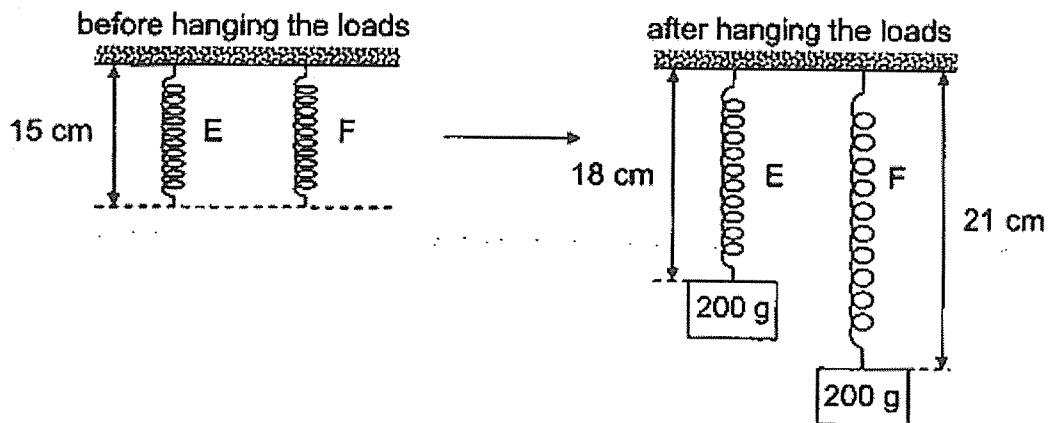

- (b) Based on the results above, which spring E or F can be used in the wooden peg in (a) to hold up a photo of greater mass? Explain your answer in terms of forces. [2]

END OF PAPER

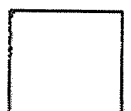

SCHOOL : CHIJ PRIMARY SCHOOL
LEVEL : PRIMARY 6
SUBJECT : SCIENCE
TERM : 2023 PRELIMINARY EXAMINATION



SECTION A

Q1	Q2	Q3	Q4	Q5	Q6	Q7	Q8	Q9	Q10
1	3	1	4	3	3	2	4	2	4
Q11	Q12	Q13	Q14	Q15	Q16	Q17	Q18	Q19	Q20
4	1	4	2	4	2	4	3	1	4
Q21	Q22	Q23	Q24	Q25	Q26	Q27	Q28		
4	3	1	3	4	3	2	2		

NAME: _____ () CLASS: P6 _____ DATE: _____

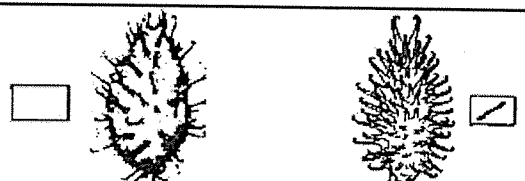
INSTRUCTIONS: Please fill in this sheet using **GREEN INK** only.

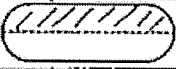
QN. NO.	CORRECTION(S)	
29	(a)	Hypothesis: The rate of photosynthesis will increase/decrease when there is more/less light.
	(b)	Gas Y: Oxygen
	(c)	As the lamp is moved further from the plant, the light intensity decrease. With less light, the rate of photosynthesis decreases, causing less bubbles to be produced.
	(d)	Add baking soda / fixed distance X
30	(a)	Y. The weight of the water is the least. The water is the dirtiest. Least amount of light will be able to pass through. The aquatic plants photosynthesis the least and will die eventually. Thus there will be the least aquatic plants found there.
	(b)	Water treatment plant. The amount of pollutant become lesser as it passes through R.
31	(a)	E. It does not depend on other organisms for food as it can make its own food.
	(b)	C will increase. X will feed on D and F, causing their population to decrease. C will have lesser predators as D and F feed on it. Thus, C will start to increase in its population.
32	(a)	(i) Benefit for fruit A: Fertilisation can occur and reproduction will take place, it will develop into a fruit.
		(ii) Benefit for insect X: The eggs of X can be protected by the fruit from its predators and have a higher chance of hatching.
	(b)	Other bigger insects will not be able to enter to eat the eggs of insect X.
	(c)	A will more nutrients for the plant to grow healthier.
33	(a)	To find out if the number of hooks on each ball affects the number of balls found stuck to the cloth.
	(b)	The greater the number of hooks on each type of ball, the greater the number of balls struck to the cloth in the end.
	(c)	Repeat the experiment a few more times and calculate the average.
	(d)	
	(e)	The fruit has more hooks so it is able to hook onto the outer covering of animals easily, so more seeds of J can be dispersed further away from their parent plant.
34	(a)	Y. It has the most haze particles collected on the mask particles able to pass through, this shows that it can block most the most of the haze particles from the lungs.
	(b)	The thickness of the mask
	(c)	Deforestation by burning of trees

QN. NO.		CORRECTION(S)		
35	(a)	<p style="text-align: center;"> Greatest transparency → Least transparency </p> <div style="display: flex; justify-content: space-around; align-items: center;"> <div style="border: 1px solid black; padding: 5px; text-align: center;">P</div> <div style="border: 1px solid black; padding: 5px; text-align: center;">R</div> <div style="border: 1px solid black; padding: 5px; text-align: center;">Q</div> </div>		
	(b)	P, Q will allow the most amount of light to be reflected. Most light from the vehicles can be reflected off the vest and into the drivers' eyes, thus allowing them to spot the officer more easily.		
36	(a)	<div style="display: flex; justify-content: space-around; align-items: center;"> <div style="text-align: center;"> F  </div> <div style="text-align: center;"> G  </div> </div>		
	(b)	Unlike poles of magnets attract each other		
	(c)	Heat E which decreases the magnetic strength of magnet E. This result in a weaker repulsion, hence E will float nearer to E.		
37	(a)	Yes, the experiment is fair as there is only 1 changed variable which is the amount of air trapped.		
	(b)	The greater the amount of trapped air, the longer the time taken for the wax to melt completely.		
	(c)	C. As C took the longest time for the wax to completely melt. C contains the most amount of trapped air and air is the poor conductor of heat, so the cooked food will lose heat the slowest to the surrounding.		
38	(a)	Freezing is the change of state of a substance from the liquid to the solid state by losing heat.		
	(b)	Warmer water vapour from the surrounding air touches the cooler outer surface of the tub, loses heat and condense to form water droplets. The water droplets the loses heat to the cooler tub of frozen yoghurt and freezes to form the white solid.		
	(c)	She can expect to see a puddle of water at the base of the tub. The white solid gained heat from the warmer surroundings and melt to water droplets.		
39	A will light up. Both P and Q are both electrical conductors, thus when S4 is closed, the circuit is closed thus electricity can flow through to light up bulb A.			
40	(a)	<div style="display: flex; justify-content: center; align-items: center; gap: 20px;"> <div style="border: 1px solid black; padding: 5px; text-align: center;">gravitational potential <small>energy (metal ball at A)</small></div> <div style="font-size: 1.5em;">→</div> <div style="border: 1px solid black; padding: 5px; text-align: center;">kinetic <small>energy (swinging to B)</small></div> <div style="font-size: 1.5em;">→</div> <div style="border: 1px solid black; padding: 5px; text-align: center;">heat <small>energy (metal ball at B)</small></div> <div style="font-size: 1.5em;">+</div> <div style="border: 1px solid black; padding: 5px; text-align: center;">sound <small>energy (metal ball at B)</small></div> </div>		
	(b)	Change a metal ball of greater mass. Metal ball of greater mass will have more gravitational potential energy converted to more kinetic energy of the metal ball upon impact with the wall B.		
41	(a)	Frictional force		
	(b)	E. As E extended to a shorter length so E is stiffer. This will cause E to extent more elastic spring force. Thus E will allow for a tighter grip to hold up a photo of greater mass.		
END OF PAPER				

