

NANYANG PRIMARY SCHOOL

2023  
PRIMARY 6  
PRELIMINARY EXAMINATION

SCIENCE  
(BOOKLET A)

Total Time for Booklets A and B: 1 h 45 min

**INSTRUCTIONS TO CANDIDATES**

1. Write your name and index number in the space provided.
2. Do not open this booklet until you are told to do so.
3. Follow all instructions carefully.
4. Answer all questions.
5. For each question from 1 to 28, four options are given.  
Indicate your choice in this booklet.  
Shade the correct oval (1, 2, 3 or 4) on the Optical Answer Sheet provided.

Name: \_\_\_\_\_ (    )

Class: Primary 6 (    )

Booklet A consists of 15 printed pages including this cover page.



**Section A: Multiple Choice Questions [56 marks]**

1. Study the diagram below.

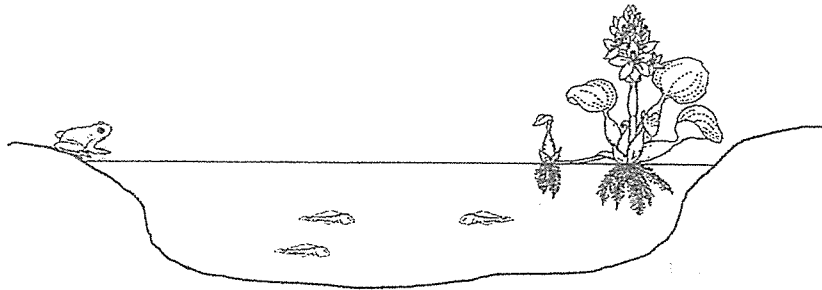

What do the frog and tadpoles above form?

- (1) a habitat
- (2) a population
- (3) an organism
- (4) a community

2. Animal K feeds on the fruits of plant T. The graphs below show the number of fruits of plant T and the number of animal K over the same period of time in the same location.

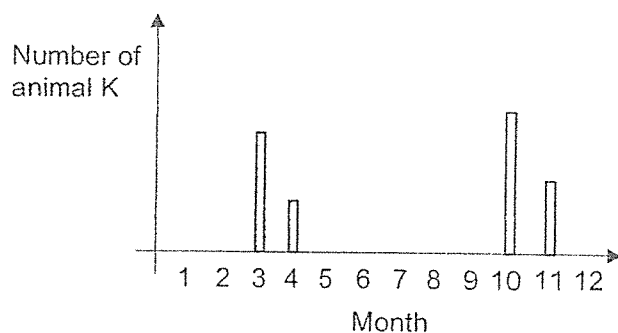
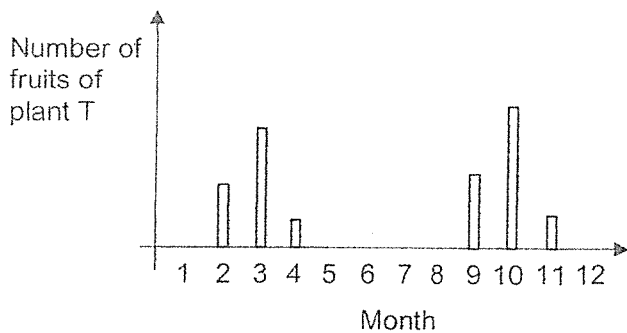

Based only on the information above, which of the following statements about the number of animal K is correct?

	Observation of Number of Animal K	Reason for Observation
(1)	increased from month 4 to 5	lack of shelter
(2)	decreased from month 4 to 5	moved to another place to search for food
(3)	remained the same from month 6 to 7	lack of predators
(4)	remained the same from month 6 to 7	number of births same as number of deaths

Study the food web below and answer questions 3 and 4.

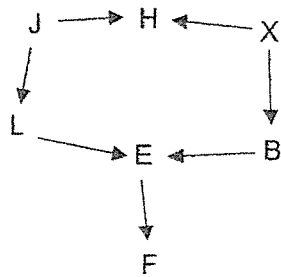

3. Based on the food web above, which one of the following correctly identifies organism H?

- (1) producer
- (2) plant-eater
- (3) animal-eater
- (4) plant-and-animal-eater

4. Based on the food web above, how many predators are there?

- (1) 1
- (2) 2
- (3) 5
- (4) 4

5. Study the food web below.

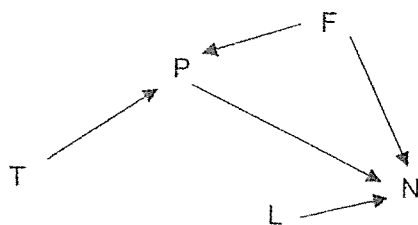

Which one of the following statements best explains the reason for an increase in the population of organism P?

- (1) population of organism T increase
- (2) population of organism N increase
- (3) population of organism F decrease
- (4) population of organism L decrease

6. Which one of the following is an example of structural adaptation?

- (1) Mosquito larvae have breathing tubes to take in air.
- (2) Birds building nests on the edge of cliffs to deter predators.
- (3) Peacocks waving tail feathers to attract the attention of mates.
- (4) Crocodiles lying under the sun to increase body temperature.

7. Study the animal below.

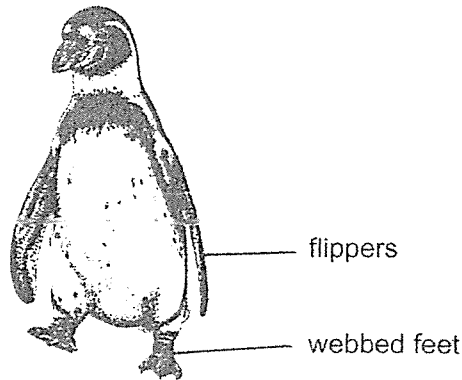

Which one of the following correctly explains the animal's adaptation to survive in an ocean habitat?

	Adaptation	Reason
(1)	Flippers	To help with swimming in water
(2)	Webbed feet	To grip prey
(3)	Streamlined body shape	To attract mates
(4)	Tightly packed feathers	To help gaseous exchange in water

8. In hot and dry habitats, some plants have thin spiky leaves as shown below.

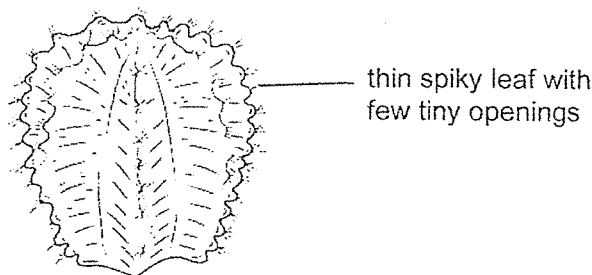

Which one of the following best explains how this adaptation allows them to survive the high daytime temperatures?

- (1) Increases the rate of photosynthesis.
- (2) Prevents plant-eaters from eating the plant.
- (3) More water can evaporate from the plant during the day.
- (4) Reduces the rate of water vapour leaving the plant during the day.

9. Study the two animals, P and L, shown below.



animal P



animal L

An experiment was conducted with the two animals, P and L, to find out the amount of time needed for them to find food in a dimly-lit cage as shown below.

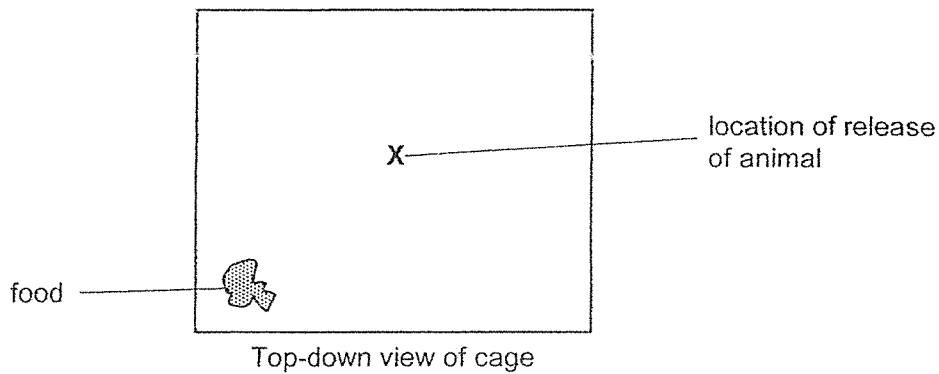

The experiment was repeated with a brightly-lit cage. The results are shown below.

Dimly-lit cage				
Animal	Time taken for animal to find food (s)			
	1 <sup>st</sup> try	2 <sup>nd</sup> try	3 <sup>rd</sup> try	Average
P	205	212	216	211
L	20	22	21	21

Brightly-lit cage				
Animal	Time taken for animal to find food (s)			
	1 <sup>st</sup> try	2 <sup>nd</sup> try	3 <sup>rd</sup> try	Average
P	23	26	23	24
L	28	22	25	25

Which one of the following is true about the findings above?

- (1) Animal P can see better than animal L in a dimly-lit environment.
- (2) Animal P took a longer time to find food in a brightly-lit environment.
- (3) Both animals P and L took the same time to find food in both environments.
- (4) Animal L is better adapted to find food in a dimly-lit environment than animal P.

10. The diagram below shows the young of animal F. After hatching, the young of animal F feeds on the egg yolk that was in the egg as shown below and the egg yolk will become smaller over time.

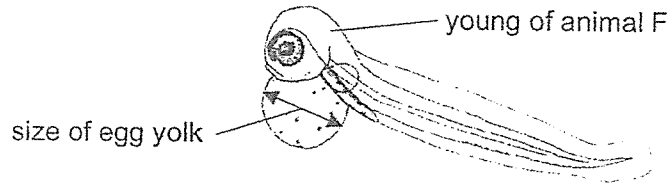

An experiment was carried out to find how the size of egg yolk during hatching affects the number of young that survive to adulthood. The results are shown below.

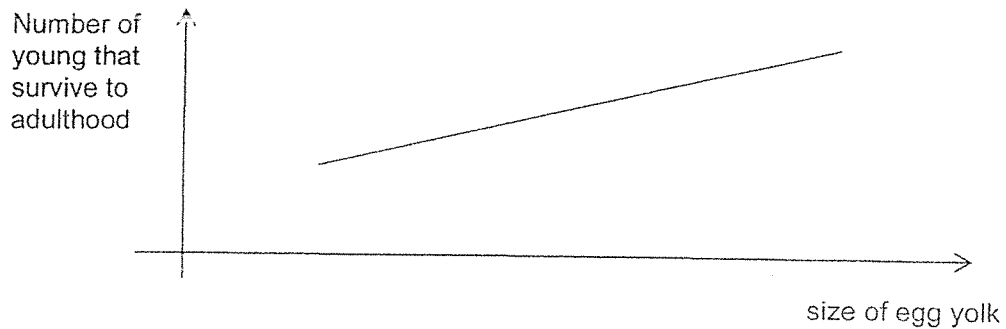

Based on the information above, which one of the following statements best explains the results?

- (1) The higher the chances of young surviving to adulthood causes a larger size of egg yolk.
- (2) A larger egg yolk during hatching increases the chances of young surviving to adulthood.
- (3) The smaller the egg yolk during hatching, the higher the chances of young surviving to adulthood.
- (4) The size of egg yolk during hatching does not affect the chances of young surviving to adulthood.

11. A large amount of plastic bags are disposed daily.

Which one of the following actions reduce the amount of plastic bags ending up in landfills and oceans?

- A Replace plastic bags with reusable bags.
- B Discard plastic bags into trash bins after one use.
- C Build recycling centres that can process plastic waste.

- (1) A and B only
- (2) A and C only
- (3) B and C only
- (4) A, B and C

12. Which of the following describes ways to reduce the rate of deforestation?

- A Create products that can replace wood and paper products.
- B Collect waste paper and use it to make new paper products.
- C Design better cutting tools to cut down trees more effectively.
- D Build concrete walls along riverbanks to prevent soil from being washed away.

- (1) B only
- (2) A and B only
- (3) C and D only
- (4) A, C and D only

13. Study the diagram below.

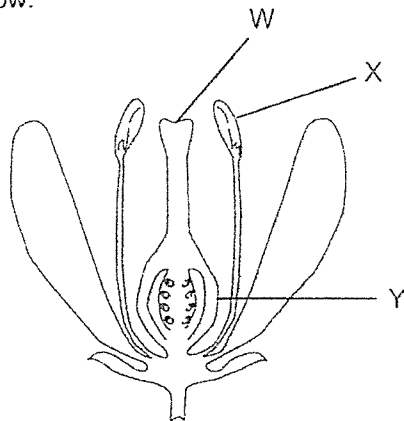

During the process of pollination, pollen grains are transferred from which part to which part?

	From	To
(1)	W	X
(2)	W	Y
(3)	X	W
(4)	X	Y

14. Study the information in the table below.

Types of cells	Parts where the cells are found	
	Parts of a flowering plant	Parts of a human
male reproductive cell	A	C
female reproductive cell	B	D

Which of the following correctly identify A, B, C and D?

	A	B	C	D
(1)	ovules	filament	testes	ovary
(2)	ovary	filament	ovary	testes
(3)	anther	ovules	ovary	testes
(4)	anther	ovules	testes	ovary

15. A farmer removed the food carrying tubes from a tree as shown in the diagram below.

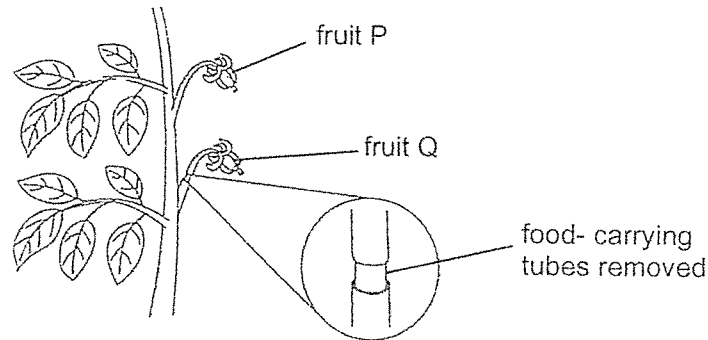

After two weeks, the farmer noticed that only fruit P became bigger.

Which of the following explains why only fruit P became bigger?

- (1) Fruit P was able to make more food than fruit Q.
- (2) Water taken in by the roots was transported to fruit P only.
- (3) Food made by the leaves was transported to fruit P but not fruit Q.
- (4) Water-carrying tubes transported more water to fruit Q than to fruit P.

16. Which of the following is a function of the human skeletal system?

- A It protects organs in the body.
- B It transports food around the body.
- C It transports blood around the body.

- (1) A only
- (2) A and B only
- (3) B and C only
- (4) A, B and C

17. Ariel was rushing home so she pushed the supermarket trolley and ran at the same time, as shown in the diagram below.



Which of the following correctly states the **main** energy conversion shown above?

	(Ariel standing still)		(Ariel running)		(trolley moving)
(1)	kinetic energy	→	potential energy	→	kinetic energy + sound energy
(2)	kinetic energy	→	kinetic energy	→	potential energy
(3)	potential energy	→	kinetic energy	→	potential energy + sound energy
(4)	potential energy	→	kinetic energy	→	kinetic energy + sound energy

18. Shirley hung a plastic ball from the ceiling using a string. She released the ball at position W and it swung to position X then to position Y, as shown in the diagram below.

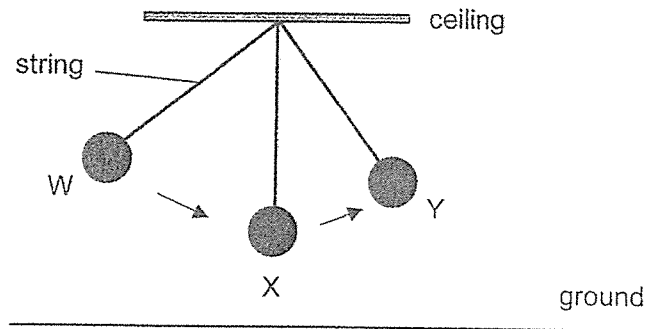

Which of the following graphs are correct?

	kinetic energy of ball from W to X	potential energy of ball from X to Y
(1)		
(2)		
(3)		
(4)		

19. Ali can easily lift a box when it is empty. However, he needed more strength to lift the box when it is filled with books.



Which one of the following explains why it was harder to lift the box when it was filled with books?

- (1) There was less frictional force between the box and the floor.
  - (2) There was less gravitational force between the box and Earth.
  - (3) There was more gravitational force between the box and Earth.
  - (4) There was more frictional force between the box and Ali's hands.
20. Toy blocks were held together by friction between the blocks. Mary attached blocks Q and R to block P. When another block S was added, blocks R and S detached from block Q and fell to the ground.

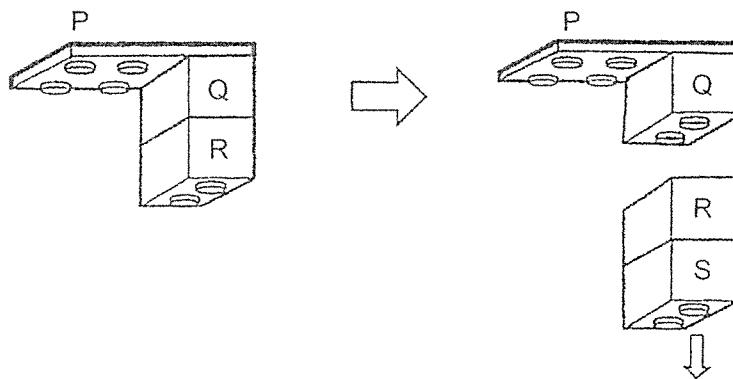

Which one of the following explains why blocks R and S fell?

- (1) The weight of S was greater than the weight of R.
- (2) Friction between R and Q was less than the total weight of R and S.
- (3) Friction between Q and P was less than the total weight of Q, R and S.
- (4) The total weight of R and S was greater than the total weight of R and Q.

21. Thomas constructed four electrical circuits as shown below.

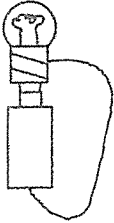

Circuit A

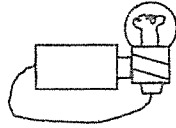

Circuit B



Circuit C

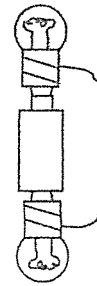

Circuit D

In which one of these four electrical circuits will the bulb(s) **not** light up?

- |     |   |     |   |
|-----|---|-----|---|
| (1) | A | (2) | B |
| (3) | C | (4) | D |

22. Study the three electrical circuits shown below. They are made up of identical bulbs, batteries and wires.

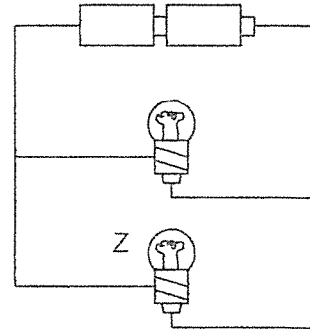
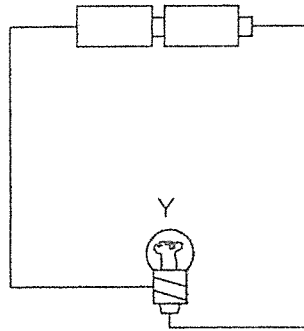
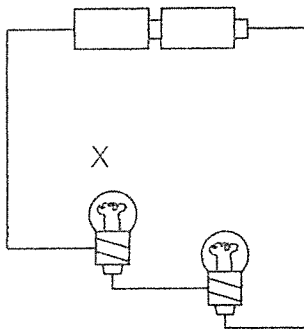

Which of the following observation(s) is/are correct?

- |   |                                 |
|---|---------------------------------|
| A | Bulb Z is as bright as bulb Y.  |
| B | Bulb X is brighter than bulb Y. |
| C | Bulb X is dimmer than bulb Z.   |
- 
- |     |              |     |              |
|-----|--------------|-----|--------------|
| (1) | A only       | (2) | B only       |
| (3) | A and C only | (4) | B and C only |

23. Which one of the following is **not** an example of using electricity safely or wisely?

- (1) Using energy saving bulbs.
- (2) Plugging in one plug per socket.
- (3) Turning off the lights when they are not in use.
- (4) Using electrical appliances with exposed wires.

24. Sue entered a dark room and could not see anything so she turned on the light. When she looked through the glass doors of a wooden cupboard, she could see the toys inside it, as shown below.

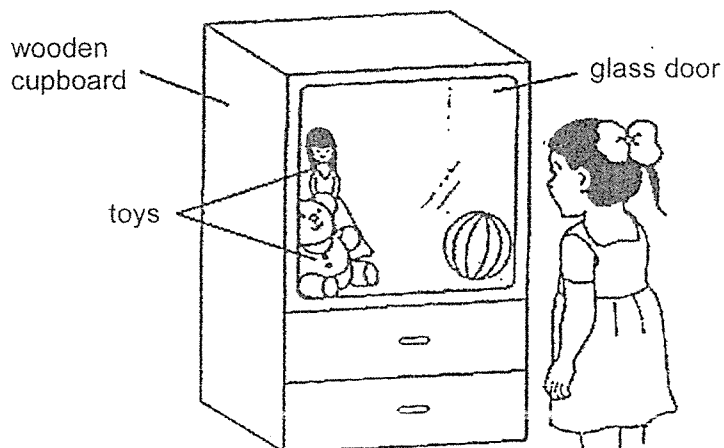

Which of the following explain(s) why she could see the toys?

- A The toys are light sources.
- B Light can pass through the glass.
- C The toys reflected light into her eyes.

- (1) A only
- (3) A and B only

- (2) C only
- (4) B and C only

25. Chris placed a cup of cold water on a wooden table as shown below.

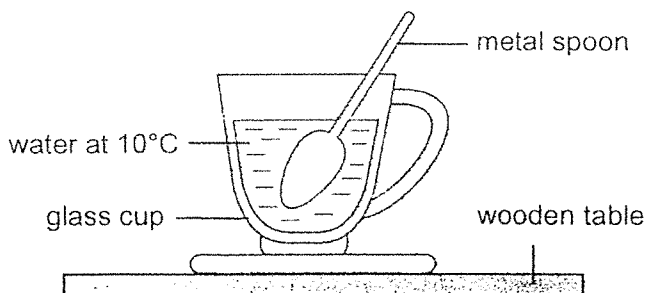

After some time, he observed that the temperature of the water had increased.

Which one of the following statements explains his observation?

- (1) The water in the cup had lost heat to the metal spoon.
- (2) The water in the cup gained heat from the surrounding.
- (3) The metal spoon gained heat from the water in the cup.
- (4) The surrounding air gained heat from the water in the cup.



28. Mary put an equal number of paperclips into two containers, A and B. She pushed two identical magnets into the two containers as shown in the diagram below.

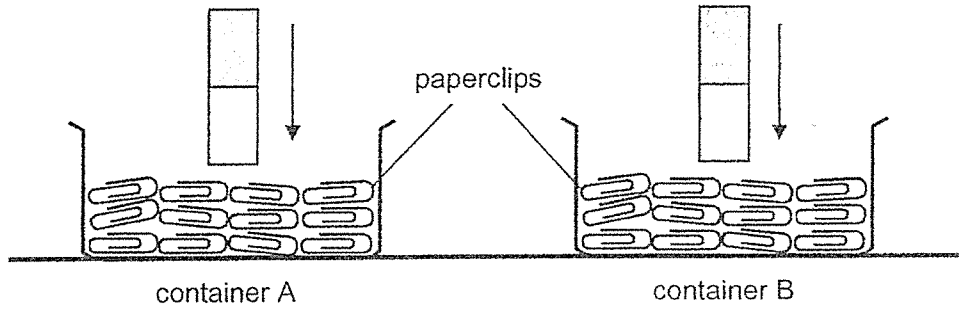

When she lifted both the magnets, she observed that the paperclips in container A were attracted to the magnet whereas the paperclips in container B were not attracted to the magnet as shown in the diagram below.

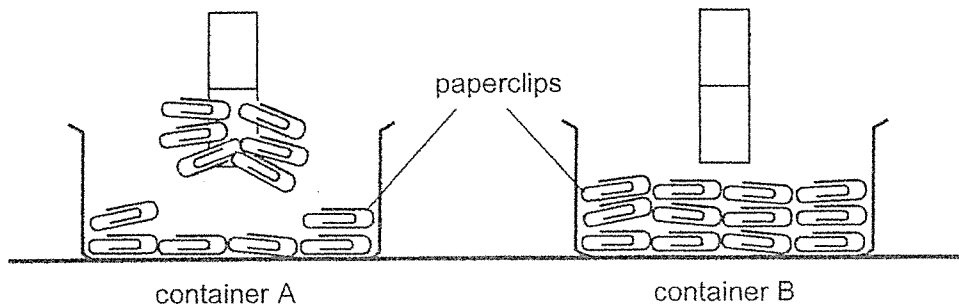

What could the materials of the paperclips in containers A and B most likely be made of?

	material of paperclips in container A	material of paperclips in container B
(1)	iron	steel
(2)	steel	plastic
(3)	plastic	plastic
(4)	plastic	iron

~ END OF BOOKLET A ~

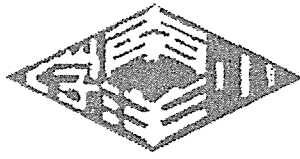

**NANYANG PRIMARY SCHOOL**

**2023  
PRIMARY 6  
PRELIMINAR EXAMINATION**

**SCIENCE  
(BOOKLET B)**

**Total Time for Booklets A and B: 1 h 45 min**

**INSTRUCTIONS TO CANDIDATES**

1. Write your name and index number in the space provided.
2. Do not open this booklet until you are told to do so.
3. Follow all instructions carefully.
4. Answer all questions.
5. Write your answers to Questions 29 to 40 in the spaces provided.

Booklet A: /56

Booklet B: /44

Total: /100

Name: \_\_\_\_\_ ( )

Class: Primary 6 ( )

Parent's signature: \_\_\_\_\_

Please sign and return the paper the next day. Any queries should be raised at the same time when returning the paper.

Booklet B consists of 17 printed pages including this cover page.

**Section B: Open-Ended Questions [44 marks]**

29. Plants, F and L, are found in the same pond as shown below.

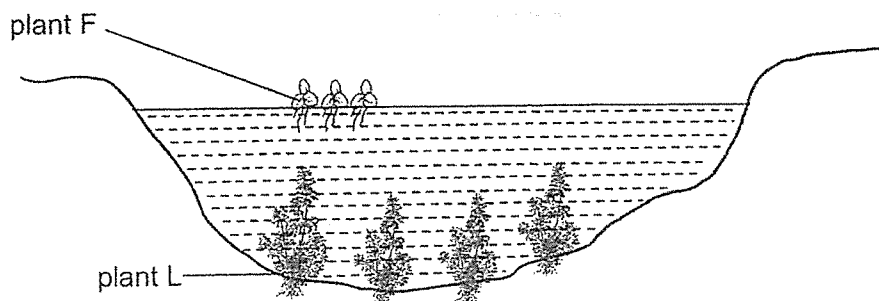

When there are heavy rains, soil is washed into the pond, increasing the amount of mineral salts in the water, causing the population of plant F to increase quickly.

- (a) An increase in the population of plant F will cause a decrease in the population of plant L. Explain why.  
[2]

---

---

---

---

---

(continue from Q29)

Animal G lives among the leaves of plant L as shown below.

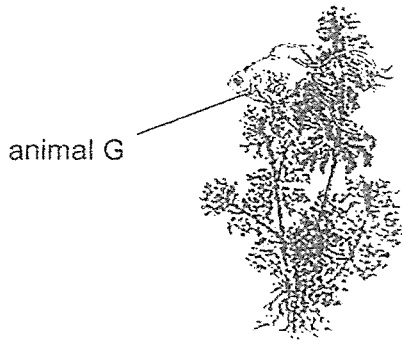

Animal G feeds on the leaves of plant L.

(b) Besides food, state two other benefits plant L can provide for animal G to ensure its survival. [2]

(i) \_\_\_\_\_

\_\_\_\_\_

(ii) \_\_\_\_\_

\_\_\_\_\_

The graph below shows the population of plant L over time.

(c) In the graph below, add another line to show the number of animal G over the same period. Label the graph. [1]

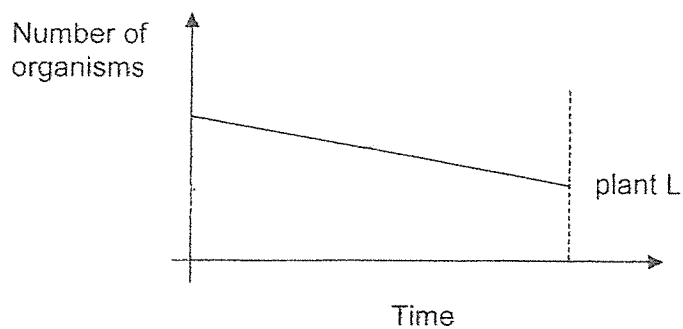

30. The food web below shows the food relationship between some organisms in a rice farm.

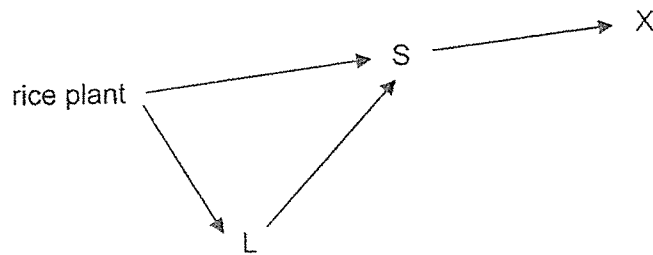

(a) Which organism(s) in the food web above is/are both predator and prey? Give a reason for your answer. [1]

---

---

The farmer increased the number of animal X hoping to increase the amount of rice harvested. However, less rice was harvested as a result.

(b) Based on the information above, explain why less rice was harvested when the farmer increased the number of animal X. [2]

---

---

---

---

---

31. Organism G attaches itself to the gills of fish R and feeds on the blood in the gills as shown below.

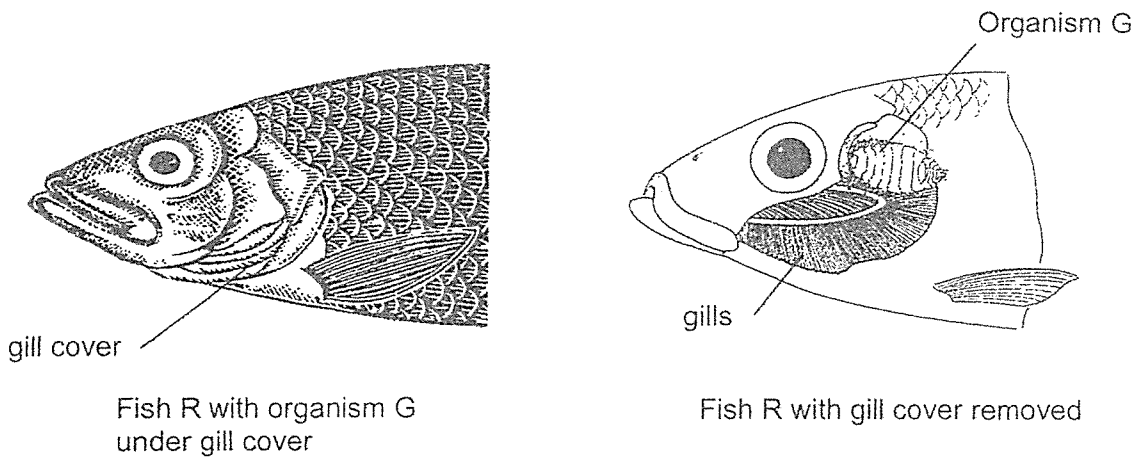

(a) Based on the information above, explain why the following actions help organism G to survive. [2]

(i) Feed on the blood in the gills:

---

---

(ii) Attach itself under the gill cover:

---

---

(b) With organism G attached to the gills, fish R receives less oxygen. Explain why. [2]

---

---

---

32. Mr Tan placed some freshly plucked leaves into a beaker of hot water. He observed bubbles escaping from both the tiny openings on the upper side and underside of the leaves, as shown in the diagram below.

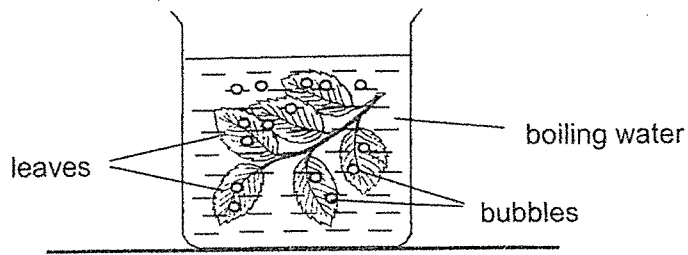

- (a) State the function of the tiny openings in the leaves. [1]

---

---

After observing the leaves, Mr Tan concluded that there are more tiny openings on the underside of the leaves than the upper side of the leaves.

- (b) What did Mr Tan most likely observe about the bubbles on the leaves that led him to make the conclusion? [1]

---

---

33. Gerald conducted an experiment to measure the volume of blood supplied to his legs per minute when he was either running on the ground or sitting on the chair during lesson. He recorded his readings in the bar graph below.

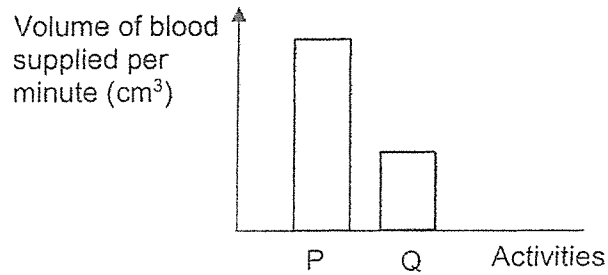

- (a) Suggest one way for Gerald to increase the reliability of his experiment's results. [1]

---

---

- (b) Which bar, P or Q, most likely represents the volume of blood supplied to his legs when he was running? Explain your answer. [2]

---

---

---

34. Samuel ate some food. He was advised to chew his food properly before swallowing.

(a) How does chewing the food into smaller pieces with the teeth help in digestion? [1]

---

---

After three hours, a doctor measured the amount of digested food in different parts of his small intestine, W and X, as shown below. He then measured the amount of water in the undigested food in different parts of Samuel's large intestine, Y and Z as shown below.

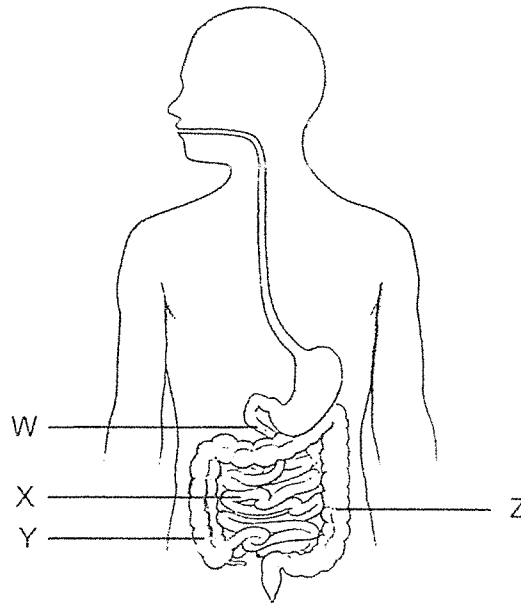

(b) Give a reason why the amount of digested food increased between W and X. [1]

---

---

(c) Give a reason why the amount of water in the undigested food decreased between Y and Z. [1]

---

---

35. Frankie set up an electric circuit as shown in the diagram below. The metal bell will produce a "ding" sound when the hammer hits the metal bell.

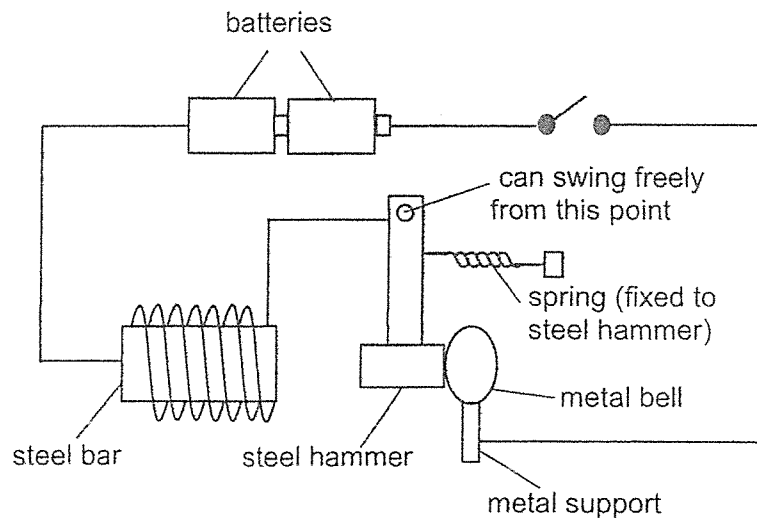

- (a) State the property of the steel bar that allows the system above to work. [1]

---

- (b) Explain how a "ding" sound was produced when a closed circuit is formed. [2]

---

---

---

---

- (c) State one change that can be made to the hammer that would allow the system to produce a louder "ding" sound. [1]

---

---

36. John conducted an experiment with a rubber band and a paper bullet. He placed the paper bullet in the middle of the rubber band and used it to pull the rubber band backwards as shown in the diagram below.

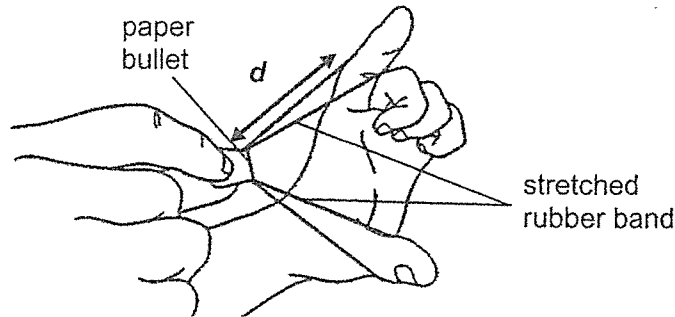

When he released the paper bullet, it would “fly” off the rubber band and land on the floor. He stretched the rubber band to different lengths,  $d$ , and recorded the distance travelled by the paper bullet in the table below.

Length of stretched rubber band (cm)	Distance travelled by the paper bullet (cm)
5	49
6	67
7	90

- (a) What was the aim of John’s experiment? [1]

---



---

- (b) State the **main** energy conversion in the boxes below. The last box had been filled for you. [1]

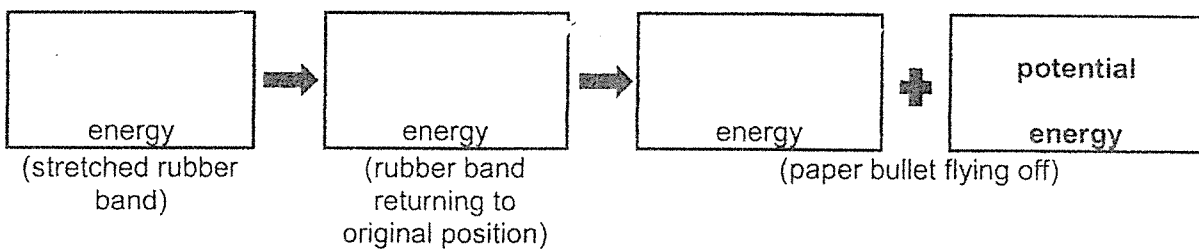

(continue from Q36)

- (c) Using the same rubber band, state two changes John can make to increase the distance travelled by the paper bullet when it is released. [2]

(i) \_\_\_\_\_  
\_\_\_\_\_

(ii) \_\_\_\_\_  
\_\_\_\_\_

- (d) Explain, in terms of energy, why the flying paper bullet will eventually come to a stop on the floor. [1]

\_\_\_\_\_  
\_\_\_\_\_



37. The table below shows the length of springs, X and Y, when blocks of different mass were hung on them as shown below.

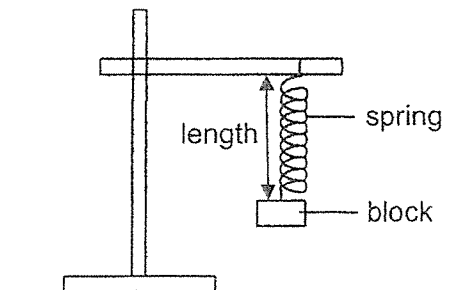

Mass (g)	Length of spring (cm)	
	X	Y
0	10	10
10	12	11
20	14	12
30	16	13
40	18	14
50	20	15

- (a) Using data from the table, explain which spring, X or Y, can extend more easily. [1]

---



---

An experiment was set up below using spring Y. The rod was horizontal when a 50g block was placed in the pan.

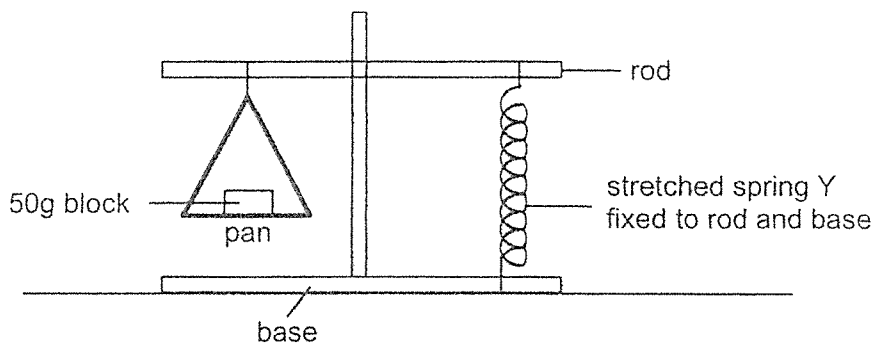

- (b) How does conducting the experiment in an environment without wind increases the accuracy of the results? [1]

---



---

(continue from Q37)

- (c) Which observations, P, Q or R, would be made when the 50g block was replaced with a 20g block?

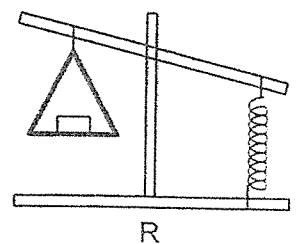
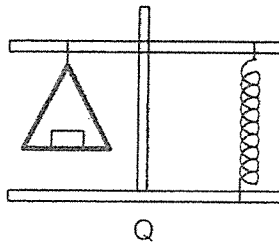
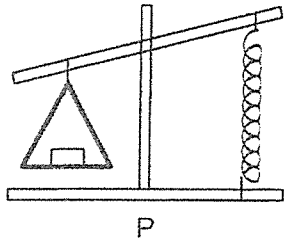

Explain your answer in terms of forces.

[2]

---

---

---

38. Jane built a circuit with three identical bulbs and two batteries. She covered parts of the wires connected to the bulbs with a piece of card as shown below. The lit bulbs could be seen through the holes in the card.

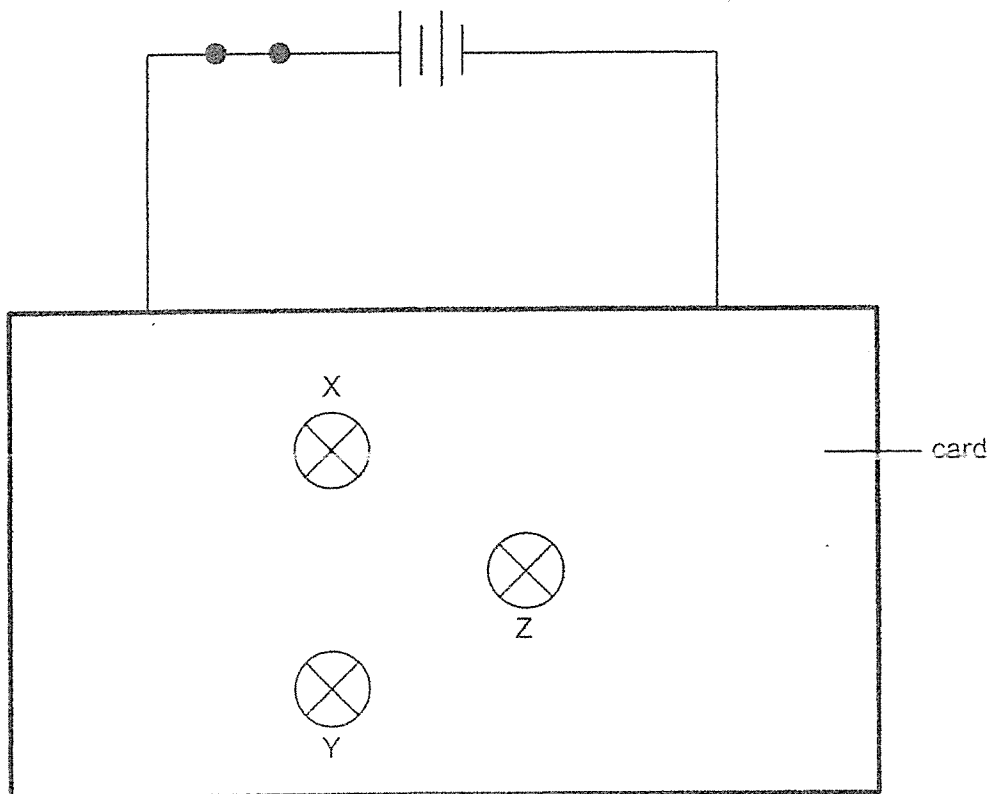

Jane removed bulbs X, Y and Z one at a time before closing the switch. She recorded her observations of how the brightness of the bulbs were affected each time, in the table below.

Bulb removed	Observation
X	Y lit up. Z did not light up.
Y	X lit up. Z lit up.
Z	X did not light up. Y lit up.

(continue from Q38)

- (a) Complete the circuit diagram below by drawing wires to show how the three bulbs could have been connected. [2]

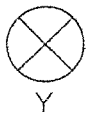
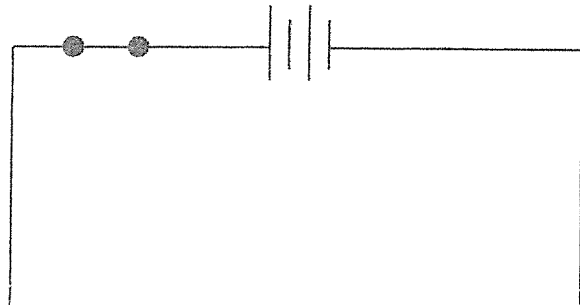

- (b) Without changing the arrangement of the bulbs, state a change that Jane could make to the circuit to increase the brightness of all three bulbs. [1]

---

39. Bala set up a light source and a light sensor to count the number of rubber bullets going through a hole in the cardboard as shown below.

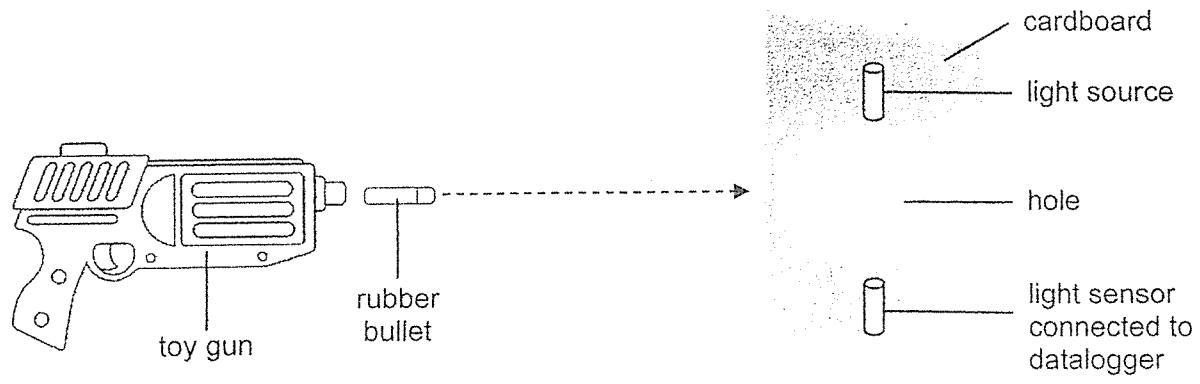

He shot the rubber bullets one at a time and recorded the results in the graph below.

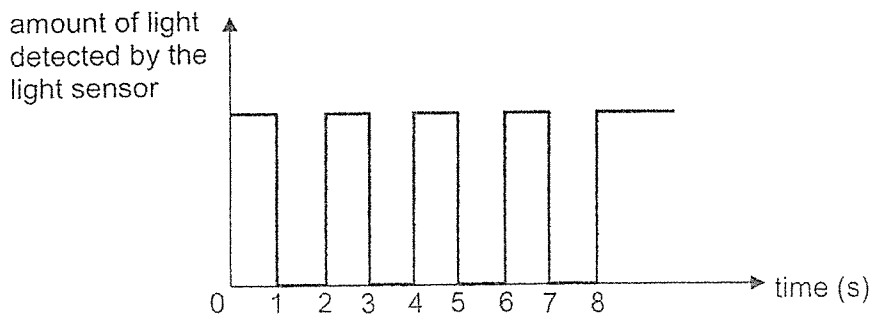

(a) Based on the graph above, how many bullets went through the hole in the first 8s? [1]

\_\_\_\_\_

(b) Explain how Bala could count the number of bullets going through the hole using the setup. [2]

\_\_\_\_\_  
 \_\_\_\_\_  
 \_\_\_\_\_

(c) Give a reason why Bala's setup was unable to count all the bullets that he shot through the hole. [1]

\_\_\_\_\_  
 \_\_\_\_\_

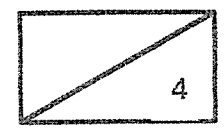

40. Tom has two cups, P and Q as shown below. He filled up both cups with the same amount of hot tea at the same temperature.

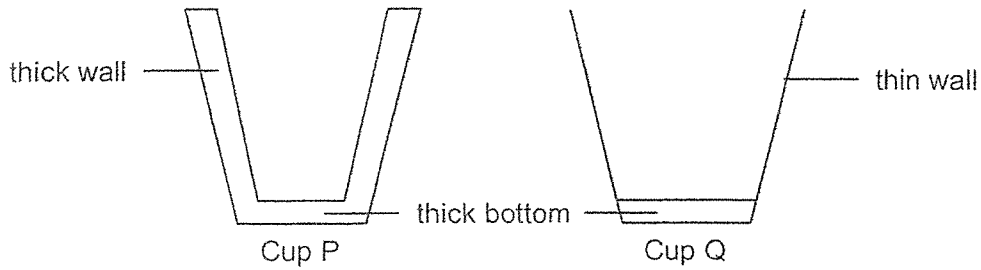

- (a) Tom observed that he could hold cup P longer than cup Q before his hands felt hot. Explain his observation. [1]

---



---

Two identical cups, S and T, were stacked together as shown below. They became stuck and Tom was unable to separate them with his hands despite using a lot of force.

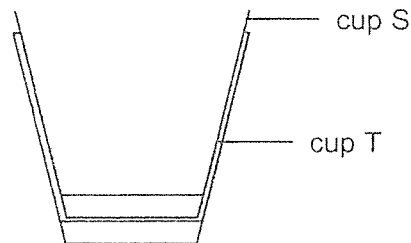

- (b) Describe and explain how Tom can use a small amount of hot water to separate the two cups safely. [2]

---



---



---

- (c) Give a reason why Tom was unable to separate the two cups, S and T, when he submerged both of them in cold water. [1]

---



---

~ END OF BOOKLET B ~



Nanyang Primary School P6 SCIENCE Prelim 2023 Suggested Answers

1	2	6	1	11	2	16	1	21	3	26	1
2	2	7	1	12	2	17	4	22	3	27	2
3	2	8	4	13	3	18	1	23	4	28	2
4	2	9	4	14	4	19	3	24	4		
5	1	10	2	15	3	20	2	25	2		

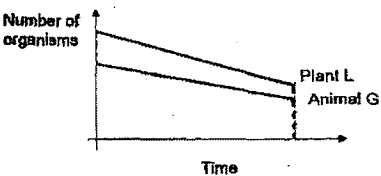
Qn.	Acceptable Answers
29a.	The population of plant L will decrease because plant F will block sunlight from passing through so plant L will have less sunlight for photosynthesis and will die.
29b.	(i) Plant L provides shelter / protection against predators. (ii) Plant L provides organism G with oxygen.
29c.	<ul style="list-style-type: none"> <li>● Downward trend</li> <li>● Must end at the same time as plant L graph</li> <li>● Must label</li> </ul> 
30a.	S is both a predator and prey. S eats L and is eaten by X.
30b.	There will be more X to feed on S so less S to feed on the rice plant and L so there is more L to feed on the rice plant.
31a.	(i) Blood provides food for organism G. (ii) Organism G can hide from its predators and will not be spotted and eaten.
31b.	Organism G feed on the blood in the gills leading to less blood for gaseous exchange/ Organism G reduces the exposed surface area of the gills (to the surrounding water) for gaseous exchange.
32a.	The function of the tiny openings is for gaseous exchange.
32b.	He observed that there are more bubbles on the underside of the leaves as compared to the upperside.
33a.	Repeat the experiment at least 3 times / 2 more times. Calculate the average result / ensure consistent readings.
33b.	<b>Choice:</b> P. <b>Data:</b> When he is running, more blood is supplied to his legs. <b>Explain:</b> His heart pumps blood rich in oxygen and digested food to his legs faster.
34a.	Chewing increases the surface area of the food for the digestive juices to act on / faster digestion.
34b.	Food is digested by the digestive juices.
34c.	Water (from the undigested food) has been absorbed into the blood.

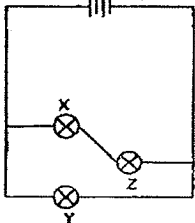
35a.	Steel is a magnetic material.
35b.	The steel bar becomes an electromagnet and attracts the hammer. The circuit is opened / electricity cannot flow through. The steel bar will be demagnetized, and the spring pulls the hammer back to hit the bell.
35c.	Use a heavier hammer/ hammer with greater mass.
36a.	To find out how the length of the stretched rubber band affects the distance travelled by the paper bullet.
36b.	(elastic) <u>potential energy</u> to <u>kinetic energy</u> to <u>kinetic energy</u> .
36c.	(i) He can pull (stretch) the rubber band backwards more (ii) He can use a lighter paper bullet.
36d.	All the kinetic energy of the paper bullet is converted to heat and sound energy.
37a.	Spring X. X extends more when the same mass was added.
37b.	Spring/block/pan/setup does not move when the measurement/reading/observation was made
37c.	<b>Choice:</b> R. <b>Data:</b> Less mass stretched the spring less. <b>Explain:</b> Less mass exerted less gravitational force (on the pan)
38a.	 <p>● X and Z in series ● Y in parallel to X and Z</p>
38b.	Add another battery (in series)
39a.	4 bullets
39b.	When a bullet goes through the hole, light is blocked from reaching the sensor, so the amount of light detected decreased to zero. Bala can count the number of times light decreases to zero.
39c.	The bullet can pass through the hole without blocking light sensor/ light.
40a.	Cup P has a thicker wall than cup Q. The thicker wall will conduct the heat from the hot tea to Tom's hand slower.
40b.	Place cup T in hot water. The walls of cup T will gain more heat from the hot water and expand more than the inner cup S.
40c.	Both cups would contract by the same amount / equally / at the same rate.