

Name : _____ () Index No.

--	--	--	--	--	--	--	--	--	--

Class : Primary 6 SY / C / G / SE / P

23 August 2022



SINGAPORE CHINESE GIRLS' SCHOOL
SECOND SEMESTRAL ASSESSMENT 2022

PRIMARY 6

SCIENCE

BOOKLET A

Additional Materials: Optical Answer Sheet (OAS)

Total Time for Booklets A and B: 1 h 45 min

INSTRUCTIONS TO CANDIDATES

1. Do not turn over this page until you are told to do so.
2. Follow all instructions carefully.
3. Answer all questions.
4. Use a 2B pencil to shade your answers on the Optical Answer Sheet (OAS).

This booklet consists of 15 printed pages and 1 blank page.



Booklet A (56 marks)

For each question from 1 to 28, four options are given. One of them is the correct answer. Make your choice (1, 2, 3 or 4) and shade your answer on the Optical Answer Sheet.

1. The respiratory system consists of _____.

- | | |
|----------|------------------|
| A: lungs | D: nose |
| B: blood | E: windpipe |
| C: heart | F: blood vessels |

- | | |
|---------------------|---------------------|
| (1) A, D and E only | (3) B, C and E only |
| (2) A, B and F only | (4) B, C and F only |

2. The diagram below shows part of the human digestive system.

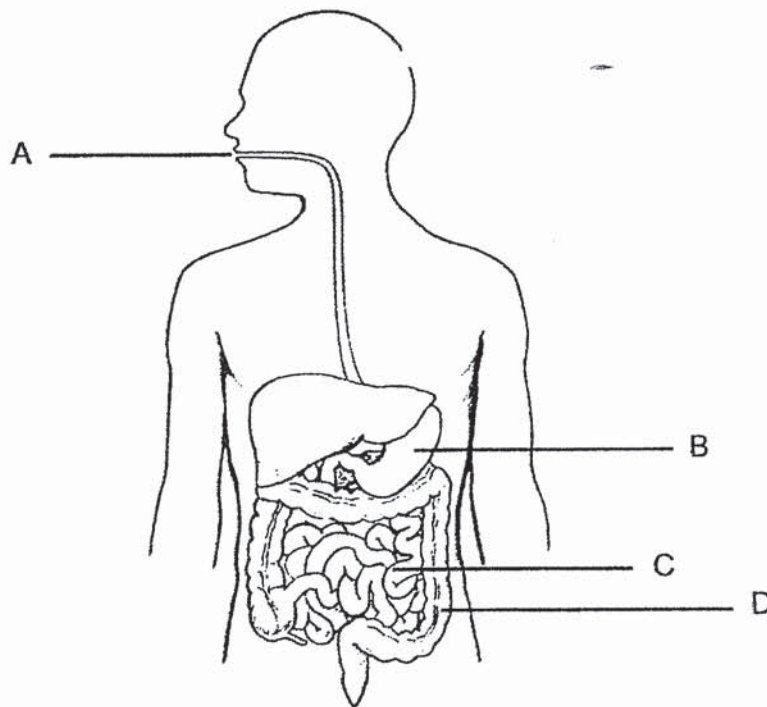

Which of the following statements is correct?

- (1) Water is absorbed in B.
- (2) Digestive juices are released at A, B and D only.
- (3) Absorption of digested food into bloodstream occurs at C.
- (4) Food is broken down at C only.

3. Bob had a plant with white flowers. He removed an outer ring from its stem at points A1, A2, A3 and A4. He then placed the plant in a beaker of red-coloured water as shown below.

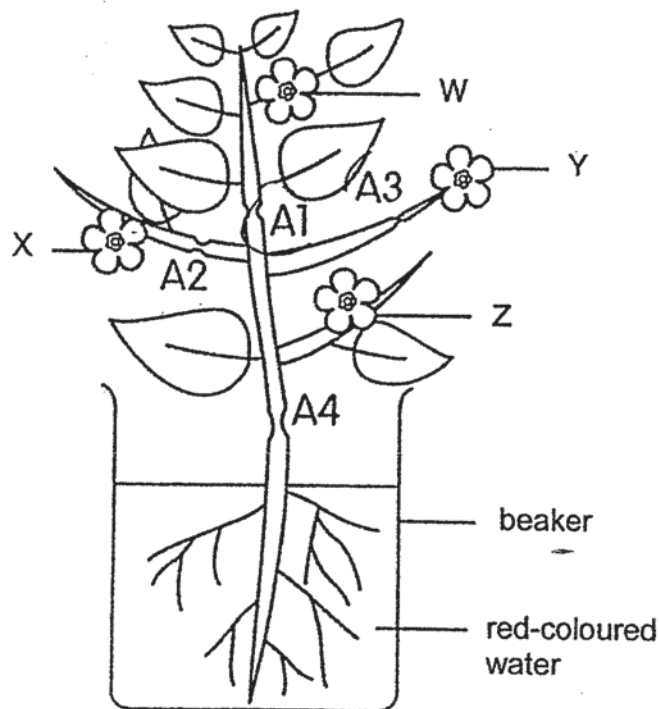

After two days, Bob observed the colours of flowers W, X, Y and Z. He recorded the results in the table below.

Flower	W	X	Y	Z
Colour	White	Red	White	Red

At which points were the water-carrying tubes removed?

- (1) A1 and A2
 (2) A1 and A3
 (3) A2 and A3
 (4) A2 and A4
4. Fabian was given four cells to observe under a microscope. He then recorded his observations in the table below.

Parts of a cell	Cell A	Cell B	Cell C	Cell D
Cell wall	No	No	Yes	Yes
Cell membrane	Yes	Yes	Yes	Yes
Nucleus	No	Yes	Yes	Yes
Chloroplasts	Yes	No	No	Yes
Cytoplasm	Yes	Yes	Yes	Yes

Which cell is most likely an animal cell?

- (1) A
 (2) B
 (3) C
 (4) D

5. The diagrams below show the female reproductive systems in a flower and in a human.

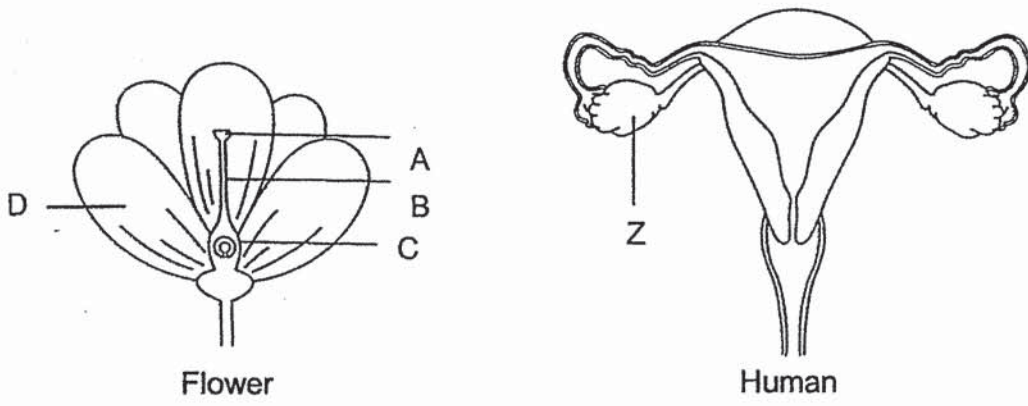

Which part, A, B, C or D, of the flower has a function similar to part Z?

- (1) A
- (2) B
- (3) C
- (4) D

6. Caslyn was shown a picture of animal Z and was told to identify whether the animal was an insect.



Animal Z

She was given four methods to decide how she could identify the animal. They are:

- A: Check to see if it can fly
- B: Count the number of legs it has
- C: Count the number of main body parts it has
- D: Find out what it eats

Which methods can she use to confirm that Animal Z is an insect?

- (1) A and C
- (2) A and D
- (3) B and C
- (4) B and D

7. Study the chart below.

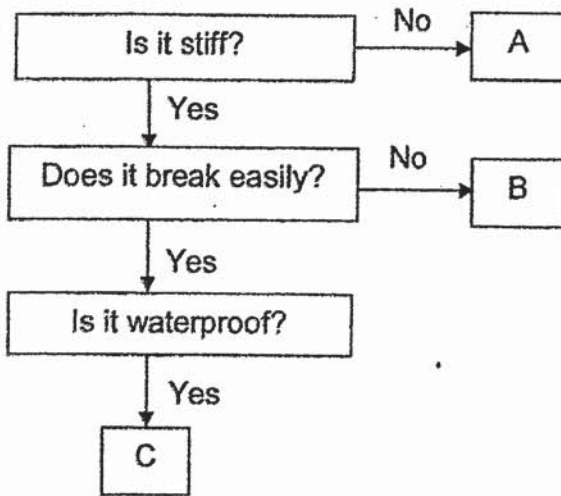

Which of the following correctly identifies objects A, B and C?

	A	B	C
(1)	Glass	Rubber band	Iron nail
(2)	Rubber band	Iron nail	Cotton
(3)	Rubber band	Glass	Iron nail
(4)	Cotton	Iron nail	Glass

8. Several tests were conducted on substances A, B and C to find out if they were a solid, liquid or gas. The results are recorded in the table below.

Test	A	B	C
Does it take the shape of the container?	Yes	No	Yes
Does it take the volume of an empty container?	No	No	Yes

Which of the following correctly shows the state of substances A, B and C?

	A	B	C
(1)	Solid	Liquid	Gas
(2)	Solid	Gas	Liquid
(3)	Liquid	Solid	Gas
(4)	Liquid	Gas	Solid

9. Deborah carried out an experiment to find out if light is needed for germination of seeds. She placed some seeds into four beakers with different conditions shown in the table below.

Beaker	Amount of water	Location of beaker
A	15 ml	In the freezer
B	15 ml	By the window
C	5 ml	In the freezer
D	15 ml	In the cupboard

Which two beakers should she use for her experiment?

- (1) A and B
 (2) A and D
 (3) B and C
 (4) B and D
10. Ella added some ice cubes to a glass of tap water as shown below.



Which of the following correctly represents what will happen to the ice cubes and tap water?

	Ice cubes	Tap water
(1)	Heat is lost	Heat is gained
(2)	Heat is lost	Heat is lost
(3)	Heat is gained	Heat is gained
(4)	Heat is gained	Heat is lost

11. Study the table below.

	Animal P	Animal Q	Animal R	Animal S
Lays eggs on land	✓		✓	
Young resembles adult		✓		
Life cycle has 3 stages only		✓	✓	✓

Use the table above to identify which animal, P, Q, R or S is a frog.

- (1) P
 (2) Q
 (3) R
 (4) S

12. Jolene used a spring balance to pull four identical blocks, A, B, C and D, along four similar surfaces in her experiment as shown below.

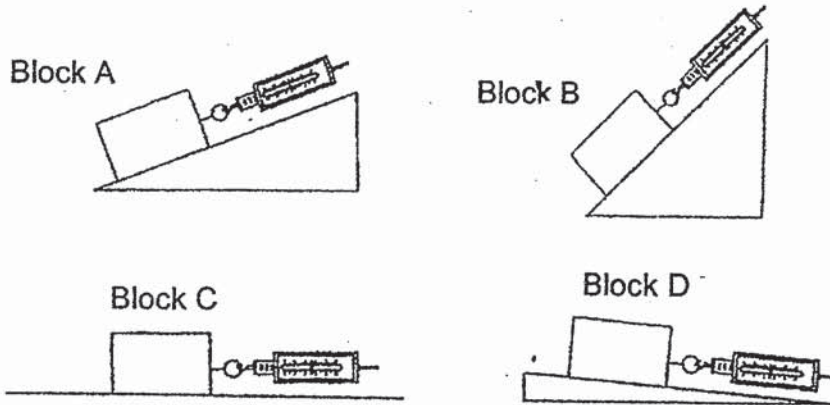

Which block requires the largest force to pull along the surface?

- (1) A
 (2) B
 (3) C
 (4) D
13. Four small steel balls, A, B, C and D, are hung from the ceiling as shown below. Only some of the steel balls are magnets.

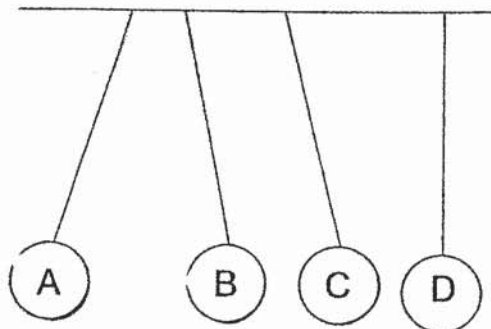

Which of the steel balls are definitely magnets?

- (1) A and B only
 (2) A, B and C only
 (3) A, B and D only
 (4) B, C and D only

14. Gabrielle sets up an electric circuit as shown below. She uses identical batteries, switches and bulbs.

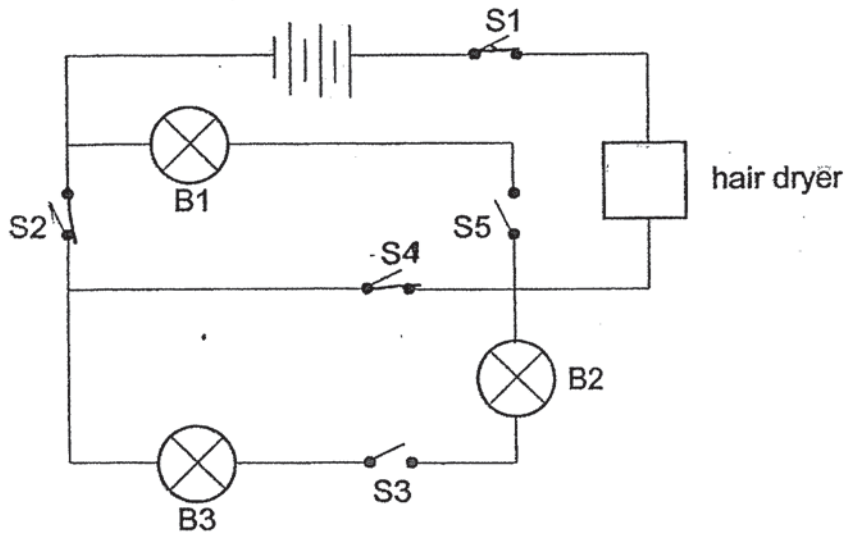

She wants to switch on the hair dryer only. Which switches should she close?

- (1) S1 and S5 only
 (2) S1, S2 and S3 only
 (3) S1, S2 and S4 only
 (4) S2, S3 and S5 only

15. The diagram below shows a lever balance with a block of material X placed on pan B.

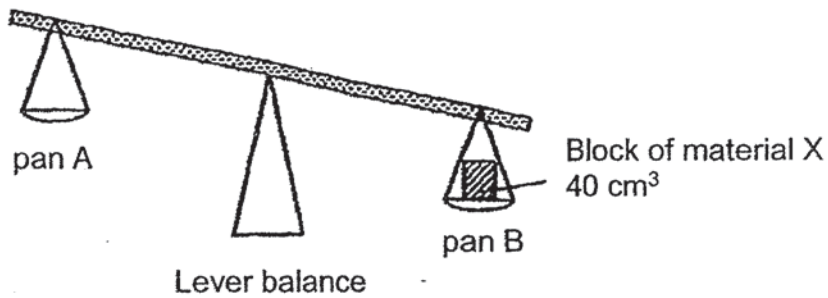

What would happen to the lever balance when a 60 cm³ block of material X is placed on the pan at pan A?

- (1) Both pans will move up and down continuously.
 (2) Pan A will be lower than the pan B.
 (3) Pan A will be higher than the pan B.
 (4) Pan A will be of the same height as Pan B.

16. Helen wanted to test how well four rods made of different materials conduct heat. At one end of each rod, she painted a strip of colour-changing paint that is sensitive to heat and turns red once it reaches 60°C and above. She inserted the four rods through holes made in a piece of cardboard and placed them in a beaker of hot water for three minutes.

The results are recorded in the table below.

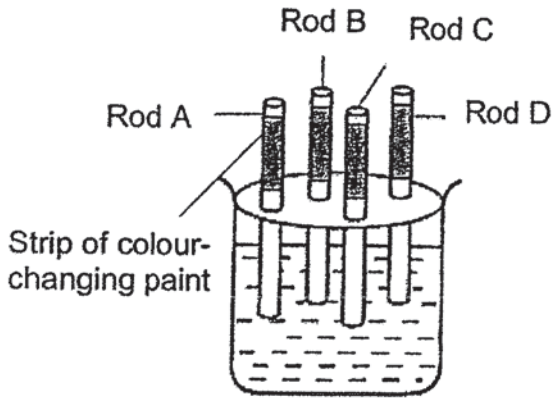

Before the experiment

	Length of colour-changing paint at start of experiment	Length of paint which has turned red after three minutes
Rod A	10 cm	10 cm
Rod B	10 cm	7 cm
Rod C	10 cm	0 cm
Rod D	10 cm	7 cm

Based on the results, which one of the following can we conclude?

- (1) Rod A is the best insulator of heat.
 - (2) Rod B is a better conductor of heat than Rod D.
 - (3) Rod C is the best conductor of heat.
 - (4) Rod D is a better conductor of heat than Rod C.
17. Three objects are shown below.

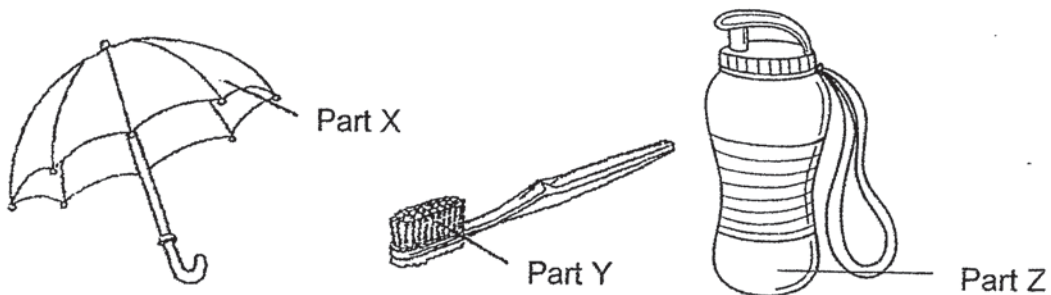

Which of the following properties is similar in the materials used for Parts X, Y and Z?

- (1) Waterproof
- (2) Transparent
- (3) Able to float
- (4) Stiff

18. The set-up below shows light shining on object P. Object P is made of materials A, B and C.

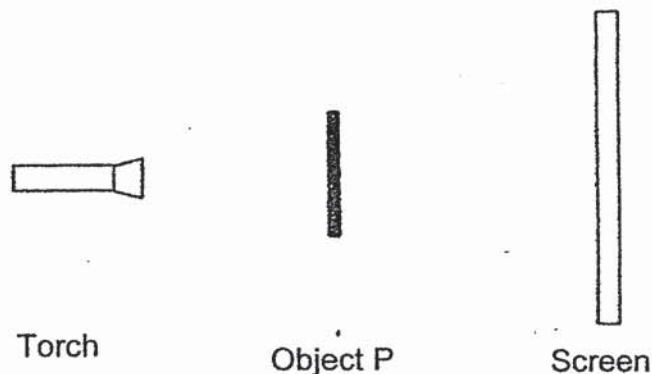

The shadow cast on the screen is shown below.
What conclusion can be made from the observation?

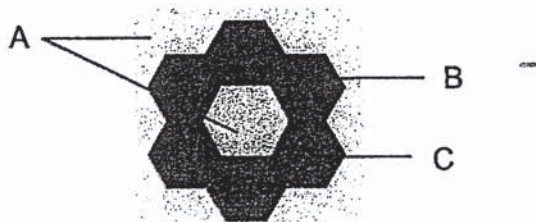

- (1) Materials A, B and C allow the same amount of light to pass through.
 - (2) Materials A and C do not allow light to pass through.
 - (3) Material A allows the most amount of light to pass through.
 - (4) Material B allows more light to pass through than materials A and C.
19. The diagrams below show Flower A and Fruit B which are taken from 2 different plants.

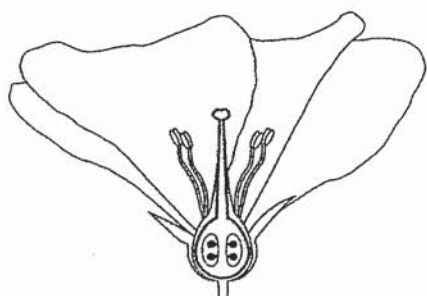

big and brightly-coloured petals

Flower A

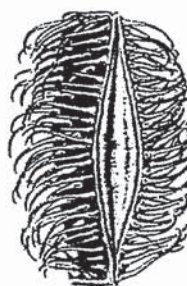

stiff hairs

Fruit B

Which of the following statements about A and B is/are correct?

- A: Both A and B need animals in their reproduction.
 B: Both A and B contain male and female reproductive cells.
 C: Pollination takes place in A but fertilisation takes place in B.

- (1) A only
- (2) B only
- (3) A and C only
- (4) A, B and C

20. Sandy fills a pot from the tap with tap water and heated it for 12 minutes until it starts to boil. She continues boiling it for another 13 minutes before adding some frozen meat.

Which of the following graphs shows the changes in the temperature of water correctly?

(1)

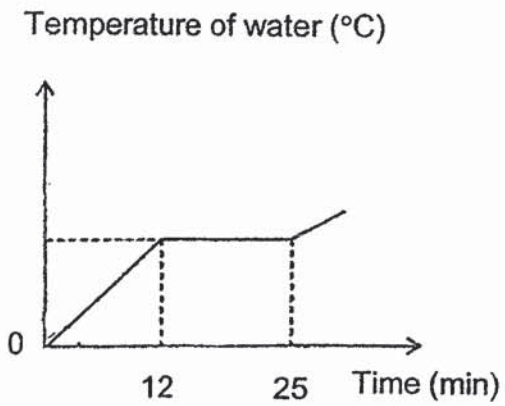

(3)

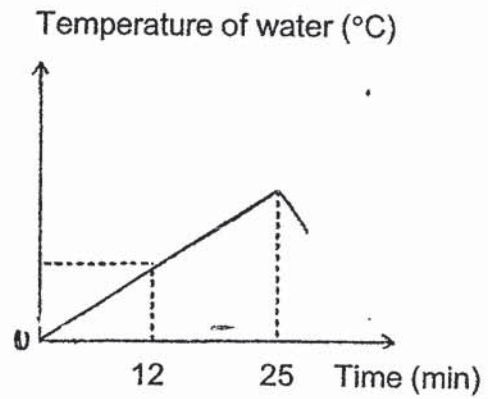

(2)

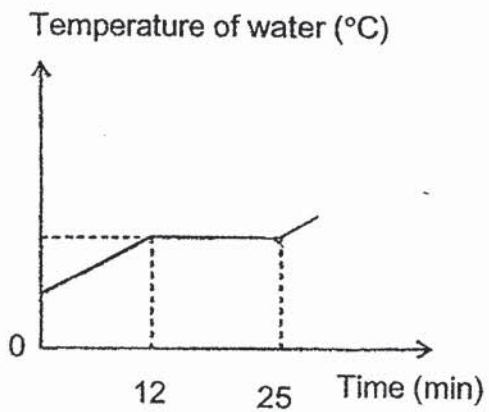

(4)

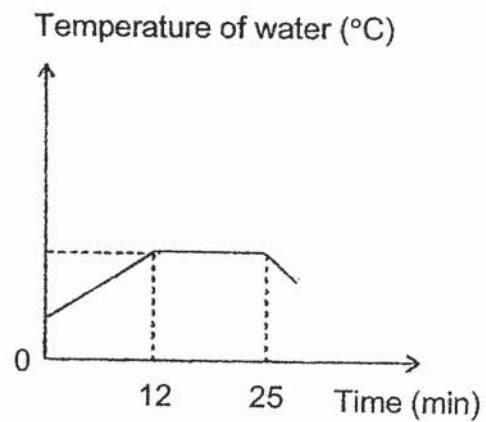

21. The diagrams below show the direction of the flow of blood in a fish and the flow of blood in a human.

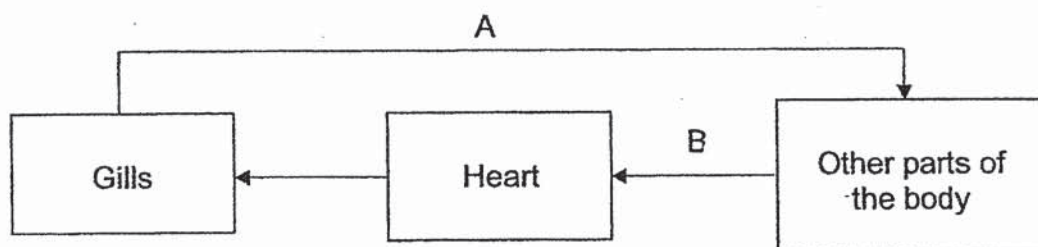

Flow of blood in a fish

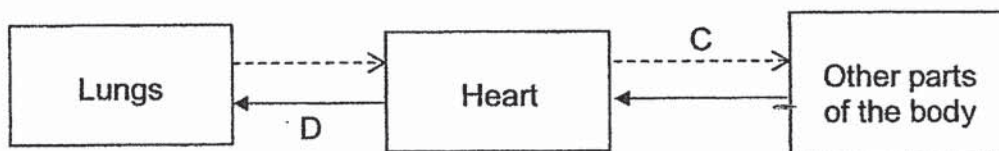

Flow of blood in a human

Which of the following correctly describes the blood vessels A, B, C and D?

	Blood rich in oxygen	Blood rich in carbon dioxide
(1)	B and C	A and D
(2)	B and D	A and C
(3)	A and C	B and D
(4)	A and B	C and D

22. Xavier placed a bottle of water on the table at room temperature as shown in the diagram below.



He wanted the water in the bottle to evaporate as fast as possible.

Which of the following methods would speed up the rate of evaporation?

- A: Place a stopper at the mouth of the bottle.
- B: Place the bottle in a warmer room.
- C: Place a fan at the mouth of the bottle.

- (1) A and B only
- (2) A and C only
- (3) B and C only
- (4) A, B and C

23. Study the 4 circuits, A, B, C and D, shown below.

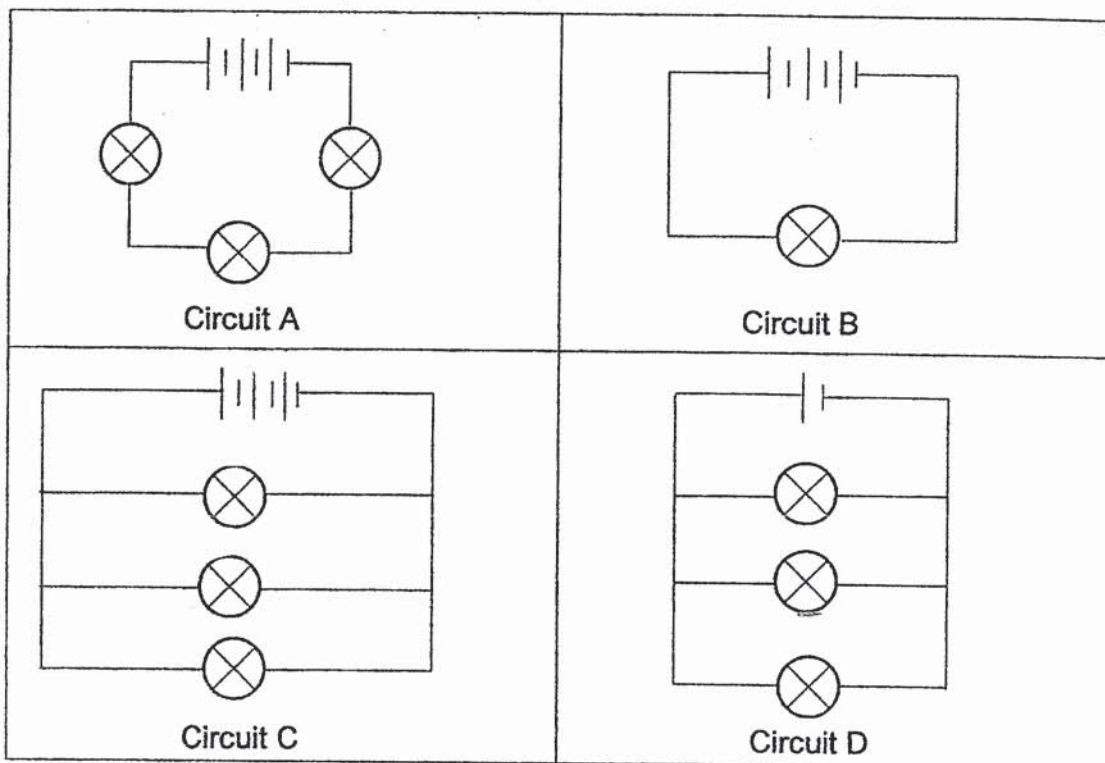

The bulbs and batteries in the circuits are identical and all the bulbs are lit. Which one of the following statements about the brightness of the bulbs is correct?

- (1) The bulb in circuit B is the dimmest.
- (2) The bulbs in circuit C are dimmer than the bulbs in circuit D.
- (3) Each of the bulb in circuit A is brighter than the bulb in circuit B.
- (4) The bulb in circuit B is as bright as each of the bulb in circuit C.

24. Study the food web in a habitat below.

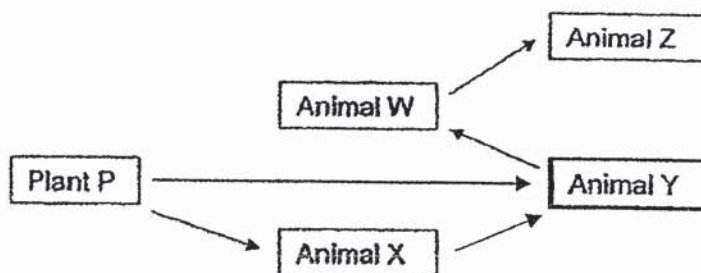

Which one of the following would result in an increase in the number of animal W in the habitat?

- (1) Plant P was infested with pests.
- (2) There is a disease outbreak which kills most of animal Z.
- (3) The habitat becomes too hot for animal X to survive.
- (4) There is a decrease in the rate of reproduction of animals Y.

25. A biologist conducted a study on organism Z and observed that it thrives in a dark and wet environment in the day.

The table below shows 2 physical characteristics, A and B, of the habitats that organisms live in.

Habitat in the day	Characteristic	
	A	B
Desert	High	Low
Garden	High	High
S	Low	High
T	Low	Low

Based on the information above, which habitat does organism Z live in and what are the physical characteristics of A and B?

	Habitat of organism Z	Characteristic A	Characteristic B
(1)	S	Amount of light	Temperature
(2)	T	Amount of light	Temperature
(3)	S	Amount of light	Amount of water in the soil
(4)	T	Temperature	Amount of water in the soil

26. The pictures below show 3 animals sharing a common physical adaptation.



Stick insect
Body is shaped like a stick



Caterpillar
Body has the same colour as leaves

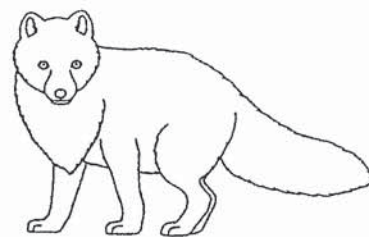

Arctic Fox
Body has the same colour as snow

Which of the following best explains the common adaptation of the 3 animals above?

- (1) To escape from predators.
- (2) To obtain food.
- (3) To keep warm.
- (4) To hunt and kill prey.

27. Study the food chain of a habitat below.

rice plant → grasshopper → sparrow → python

A new organism Y was introduced to the habitat and it affected the population of sparrow as shown in the graph below.

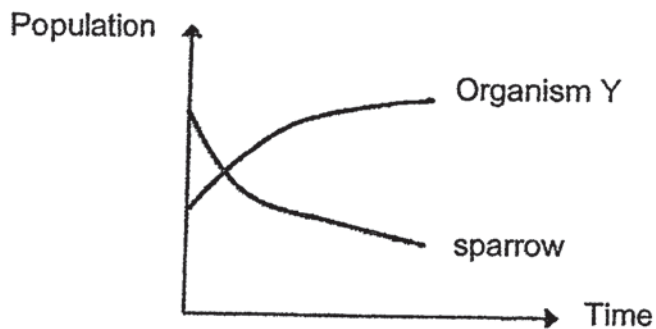

Which of the following correctly shows the likely changes to the populations of rice plant, grasshopper and python when Organism Y has been introduced?

	Rice plant	Grasshopper	Python
(1)	Decrease	Increase	Decrease
(2)	Decrease	Decrease	Increase
(3)	Increase	Increase	Decrease
(4)	Increase	Decrease	Increase

28. The diagram below shows a rotting log habitat.

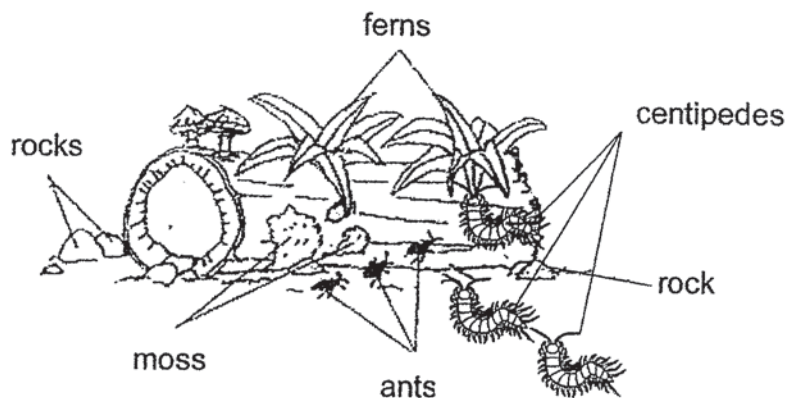

How many populations of food producers and food consumers are present in this habitat?

	Number of population of	
	Food producers	Food consumers
(1)	2	1
(2)	2	2
(3)	3	1
(4)	3	2

End of Booklet A

BLANK PAGE

Index No.

--	--	--	--	--	--	--	--	--

Name : _____ ()

23 August 2022

Class : Primary 6 SY



SINGAPORE CHINESE GIRLS' SCHOOL
SECOND SEMESTRAL ASSESSMENT 2022

PRIMARY 6

SCIENCE

BOOKLET B

Total Time for Booklets A and B: 1 h 45 min

INSTRUCTIONS TO CANDIDATES

1. Do not turn over this page until you are told to do so.
2. Follow all instructions carefully.
3. Answer all questions.
4. Write your answers in this booklet.

	Max Mark	Marks attained
Booklet A	56	
Booklet B	44	
Total Marks	100	

Parent's Signature

This booklet consists of 14 printed pages.

Part II (44 marks)

For questions 29 to 41, write your answers in this booklet.

The number of marks available is shown in brackets [] at the end of each question or part question.

29. The chart below shows the different properties of plant parts A, B and C.

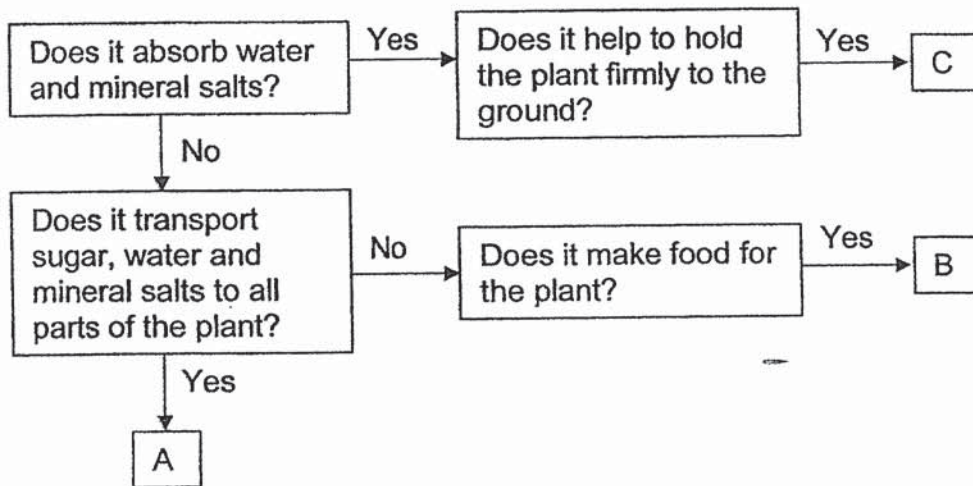

(a) Based on the chart above, identify the plant parts represented by A and C. [1]

A: _____

C: _____

(b) State two substances that B needs to take in to make food. [1]

1. _____

2. _____

30(a) The diagram below represents how the blood travels in the body.

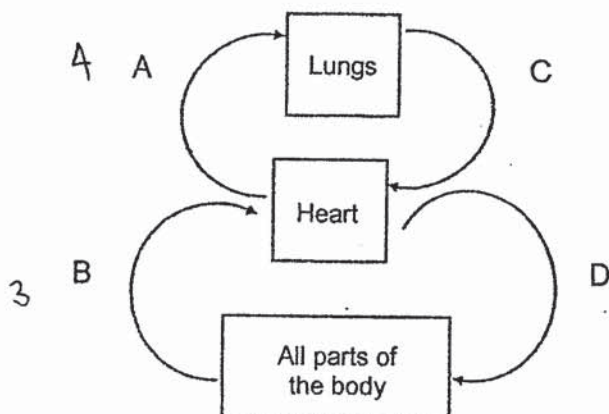

In which blood vessel, A, B, C or D, will the amount of carbon dioxide be the highest? [1]

(b) Rina, a healthy 28-year-old person, is running on a treadmill in a gym. The graph below shows the relationship between her speed of running and her heart rate.

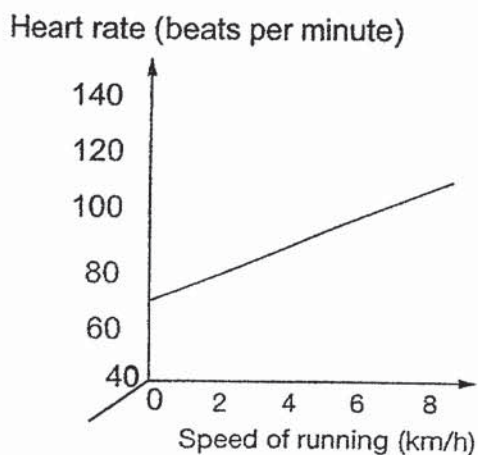

(i) State the relationship between Rina's heart rate and speed of running. [1]

(ii) Explain why Rina's heart rate changes when she runs faster. [2]

31. Henry set up an experiment as shown in Diagram 1. Similar aquatic plants were placed in both set-ups A and B under strong sunlight.

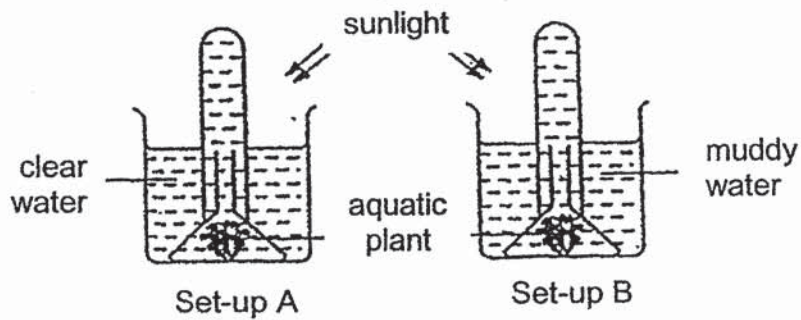

Diagram 1

- (a) What is the aim of the experiment? [1]

Henry observed that gas X was produced in Set-up A after some time.

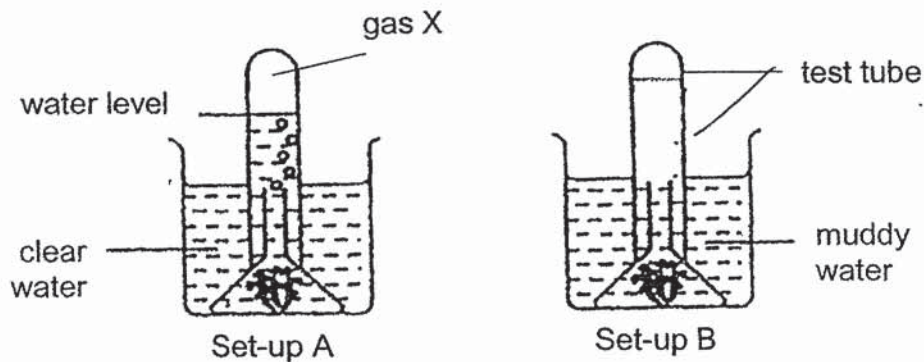

Diagram 2

- (b) Name the gas X produced in Set-up A. [1]

- (c) The diagram for set-up B in Diagram 2 is incomplete. Draw the water level in the test-tube in set-up B above in Diagram 2 and explain your answer. [2]

- 32(a) Zoe studied five organisms, A, B, C, D and E, living in the garden community for a week.
She recorded her findings in the table below.

Organism	Food
A	E
B	A and E
C	B and D
D	A and B

Identify the food producer from the information above.

[1]

- (b) Use the above information to construct a food web in the space below.

[2]

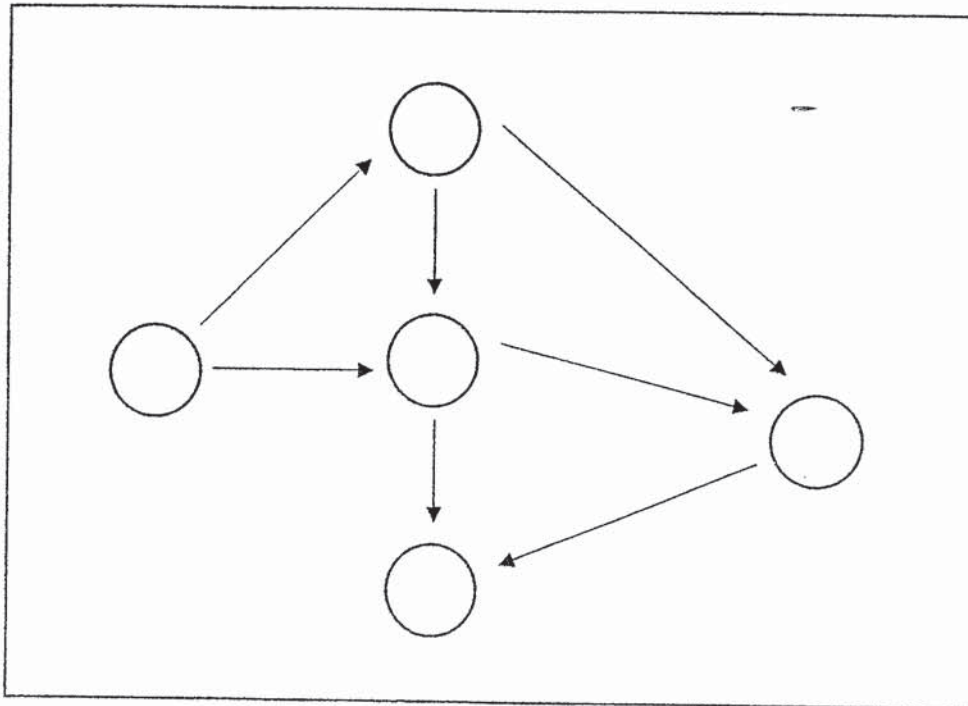

33. Farmer Z planted his crops on a slope as shown below.

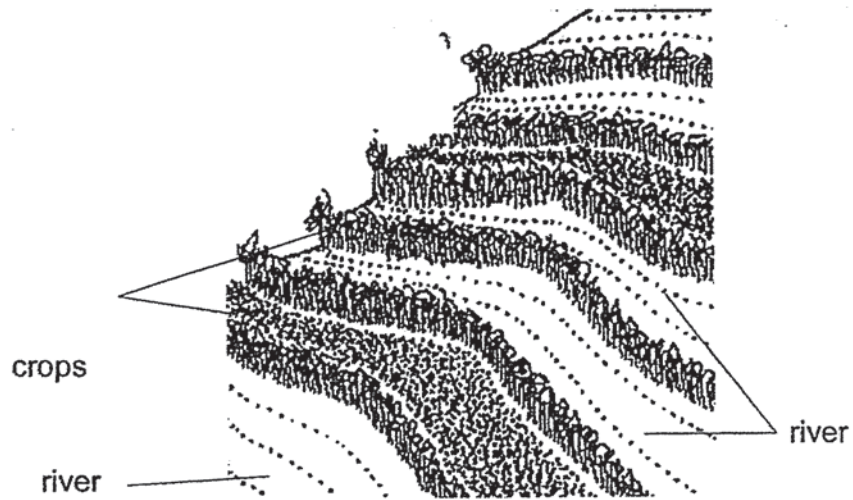

Due to an increase in the pests and insects which attacked the crops, he used an excessive amount of pesticides to maintain his harvest.

- (a) Explain how the aquatic life in the river would be affected by Farmer Z's excessive use of pesticides on his crops. [1]

- (b) Explain how planting crops on the slopes helps to prevent soil erosion when it rains. [2]

34. Joe had two groups of fruits, A and B, as shown below.

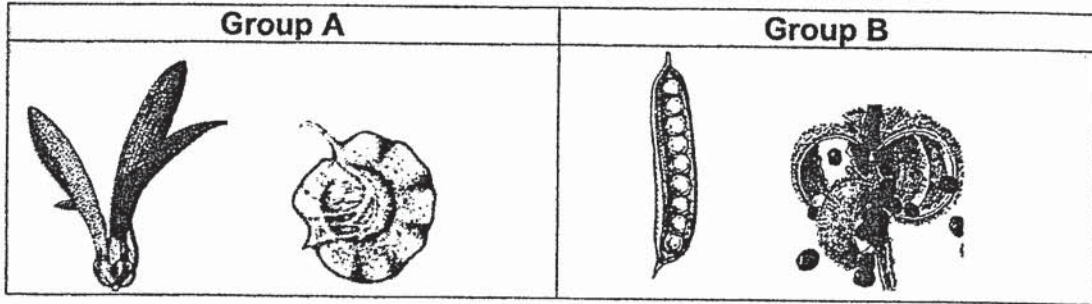

The seeds from two different types of plants, X and Y, were dispersed on land. The seeds germinated and grew into young plants after two months as shown below.

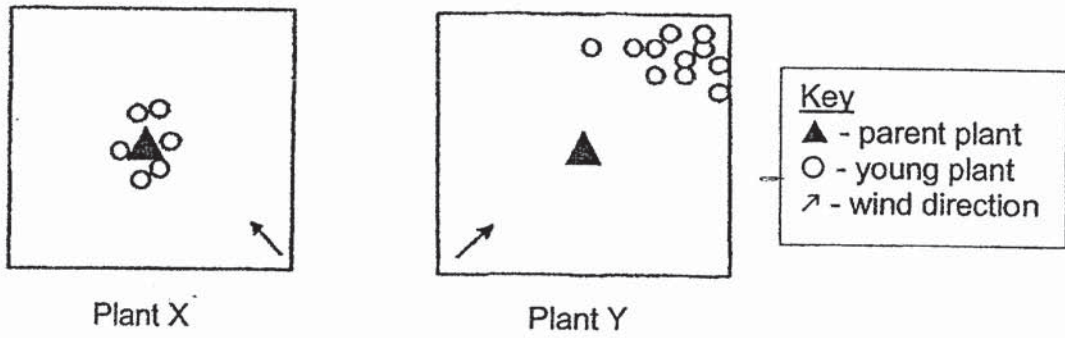

(a) Based on the above diagrams, identify which group, A or B, do plants X and Y belong to. State a structural adaptation of the fruit that enables you to reach your conclusion. [2]

Plant X belongs to Group _____

Structural adaptation of fruit of Plant X:

Plant Y belongs to Group _____

Structural adaptation of fruit of Plant Y:

(b) Based on the diagrams above, state one advantage of Plant Y's dispersal method over Plant X's dispersal method. [1]

35. Wendy conducted an experiment using the set-ups X and Y shown below. The two containers were identical and contained 100 cm^3 of hot water at 80°C . Only set-up X was wrapped with bubble wrap.

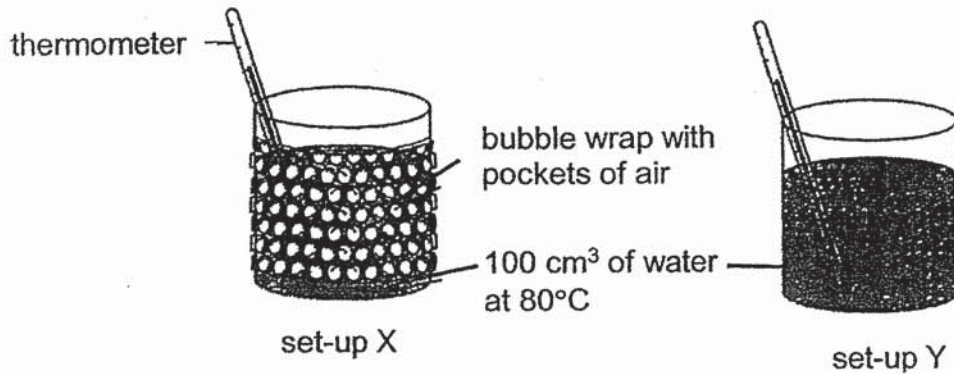

- (a) After some time, Wendy observed that the temperature of water in set-up X was higher than in set-up Y. Explain Wendy's observation. [2]

- (b) On a cold morning, a bird puffs up its feathers.



Based on the findings from Wendy's experiment, explain how puffing up of feathers helps to keep the bird warm. [2]

36(a) Iris dropped two balls, X and Y, of the same size but different mass into a tray of flour from the same height as shown below.

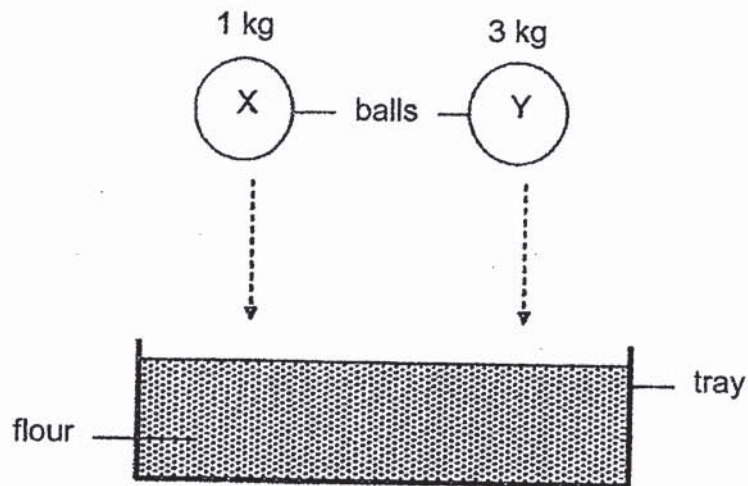

(i) Complete the energy conversion from the moment the balls were released till they reached the tray of flour. [1]

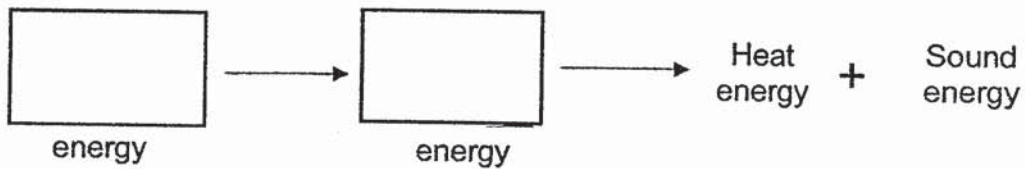

Iris recorded the depth of the dent made by each ball in the tray of flour in the table below.

Ball	Depth of dent (cm)			Average
	1 st try	2 nd try	3 rd try	
X	1.0	1.5	1.0	1.17
Y	3.0	3.5	3.5	3.33

(ii) Based on the results in the table above, give a reason why Ball Y made a deeper dent than Ball X. [1.5]

(b) Two identical pots fell from the 14th and 2nd floor of an apartment block and landed on a sand pit. Explain why the pot that fell from the 14th floor cause a deeper dent in the sand pit. [1.5]

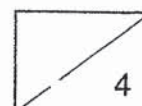

37(ai) Triston set up the circuit as shown below.

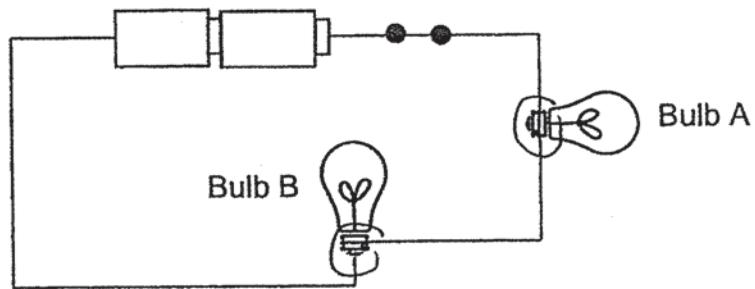

State what Triston will observe when the switch is closed. [1]

Bulb A: _____ Bulb B: _____

(aii) Explain your answer for bulb B. [1]

(b) Triston conducted another experiment. He was given the following items:

- 4 batteries
- 4 light bulbs (bulbs 1, 2, 3, 4)
- Wires

Triston was told that either light bulbs 1 or 2 had fused and he had to determine which light bulb had fused. Bulbs 3 and 4 were connected in series as shown below.

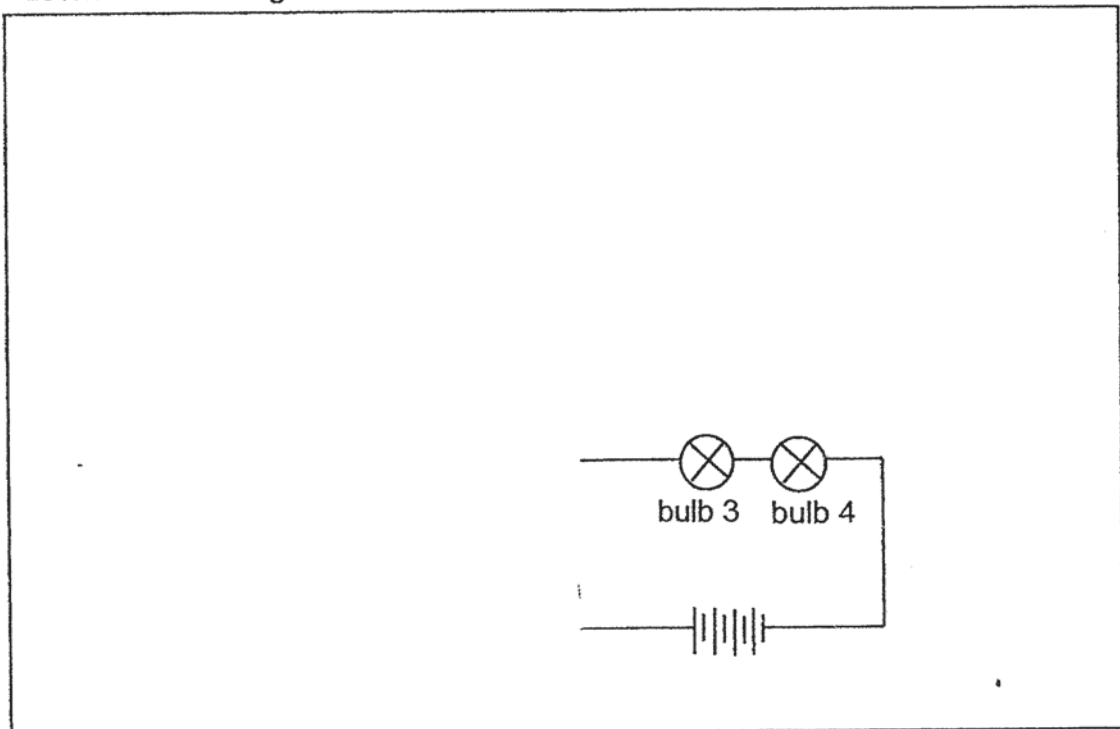

Complete the circuit diagram to show how Triston could connect the circuit to determine which light bulb had fused. [2]

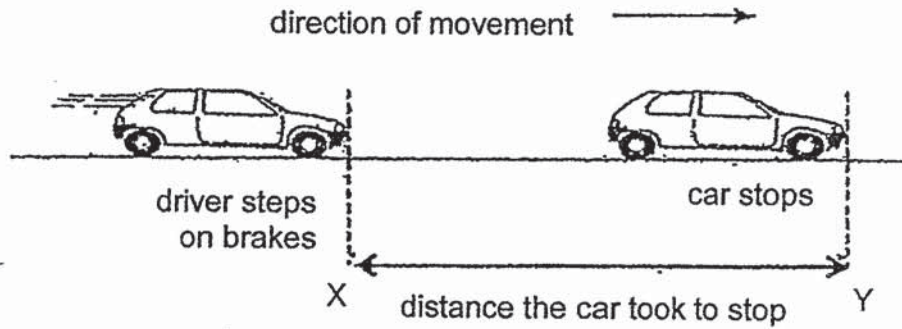

38. Two cars of equal masses, with tyres of the same size, were travelling at the same speed as shown below. The brakes were applied at the same instant and the distance the cars took to stop were measured and recorded in the table below.



The table below shows the types of tyre and their tyre threads each car had.

Car	Distance the car took to stop (m)	Type of tyre
R	10	 <p>Tyre thread</p> <p>[Not drawn to scale]</p>
S	20	 <p>Tyre thread</p> <p>[Not drawn to scale]</p>

- (a) What are the forces acting on the car at Point X? [1]

- (b) Based on the results above, explain why Car R travelled a shorter distance before it came to a stop compared to Car S. [2]

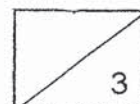

39. Keith has a double pot which has an inner and an outer pot made of steel.

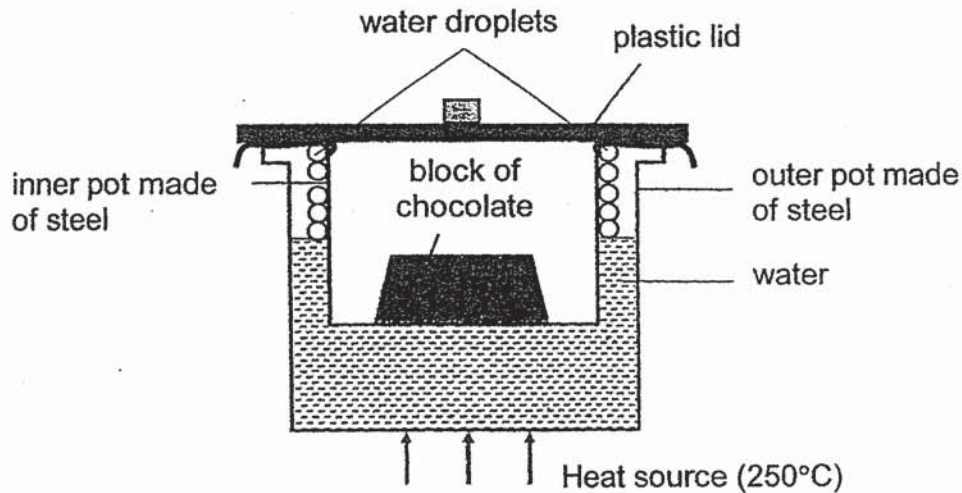

The table below shows the change in temperature of the water in the outer pot when it is heated.

Time (min)	3	6	9	12	15
Temperature (°C)	40	60	80	100	?

- (a) State the temperature of the water at the 15th minute. [1]
-
- (b) Chocolate burns at 175°C. How does having the water in the pot ensure that the chocolate will not burn? [1]
-
- (c) Keith noticed water droplets were formed on the outside of the inner pot. Explain how the water droplets were formed. [2]
-
- (d) Some time after heating the water, Keith noticed that there were fewer water droplets forming on the outside of the inner pot even when water was still boiling. Suggest a possible reason for this observation. [1]
-

40. The diagram below shows a paper counting system made up of a datalogger and a light sensor. Paper A is placed at a fixed distance between the light source and the light sensor. The light sensor measures the amount of light passing through the paper.

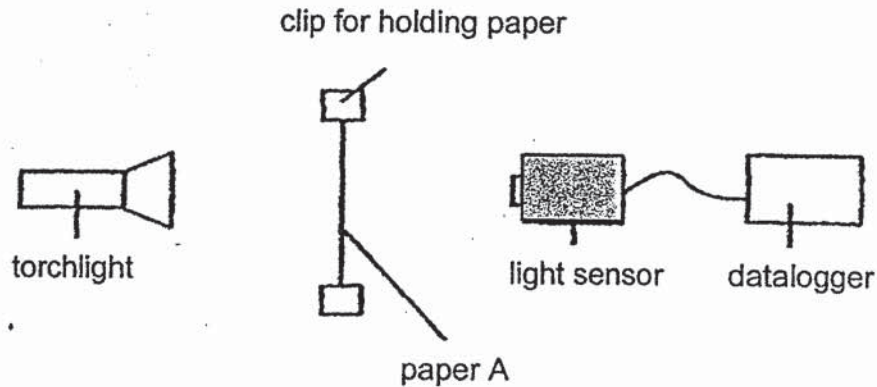

The graph below shows the number of sheets of paper A and the amount of light measured by the light sensor.

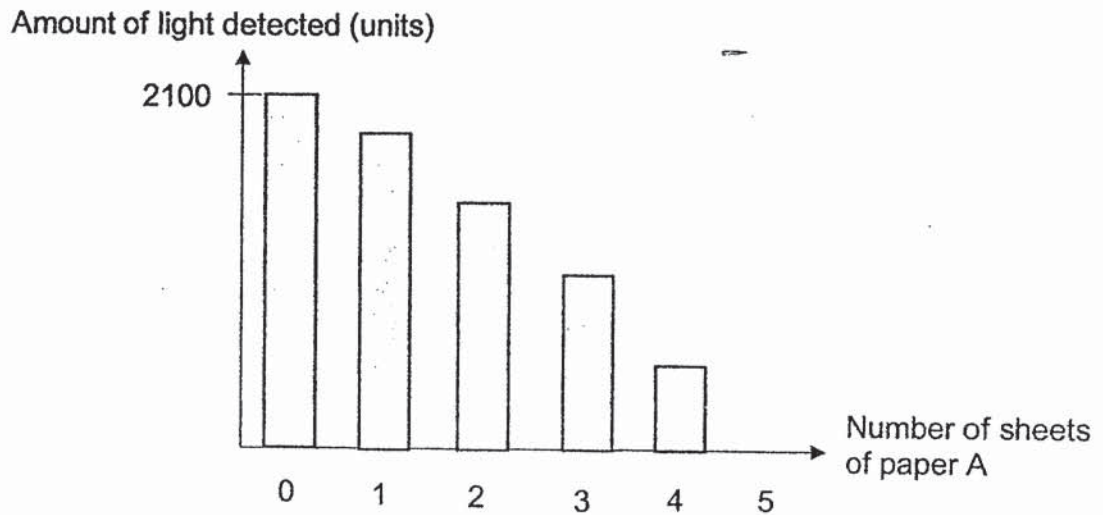

- (a) Alice wanted to make a curtain which would help to block out some light for her doll house. State the maximum number of sheets of paper A she could use. [1]

- (b) Explain why the amount of light detected decreased as the number of sheets of paper A increased. [1]

- (c) Suggest why does carrying out the experiment in a dark room improve the experiment? [1]

41. Janet wanted to investigate the magnetic strength of four electromagnets of different materials, P, Q, R and S. The materials are inserted into the coil as shown below, one at each time.

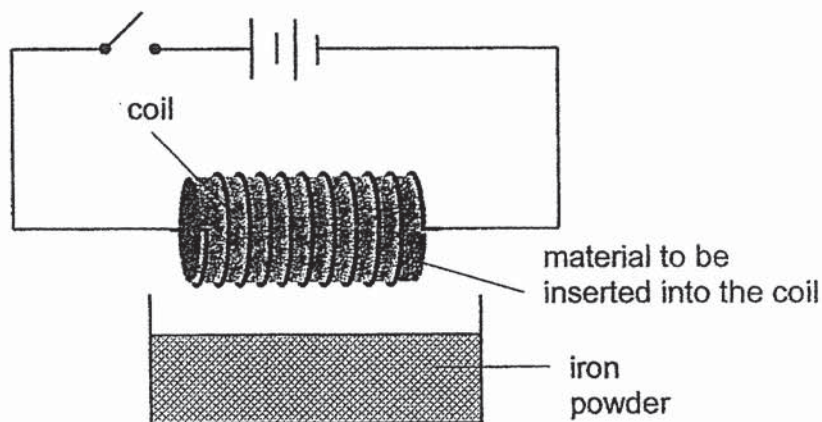

When the switch is opened, the mass of the iron powder in the tray is 500 g. When the switch is closed, the rod attracted some of the iron powder. The mass of the iron powder left in the tray for each of the four rods was recorded in the table below.

Rod	Mass of iron powder left in the tray (g)
P	260
Q	450
R	300
S	380

- (a) Based on the results in the table above, which rod is the strongest electromagnet? [1]

- (b) Janet repeated the experiment by replacing the tray of iron powder with 500 g of silver powder.

Predict the mass of silver powder left in the tray when the switch is closed for rod Q. Explain your answer. [1]



SCHOOL : SINGAPORE CHINESE GIRLS' SCHOOL
LEVEL : PRIMARY 6
SUBJECT : SCIENCE
TERM : 2022 PRELIM

SECTION A

Q1	Q2	Q3	Q4	Q5	Q6	Q7	Q8	Q9	Q10
1	3	2	2	3	3	4	3	4	4
Q11	Q12	Q13	Q14	Q15	Q16	Q17	Q18	Q19	Q20
4	2	2	3	2	4	1	3	1	4
Q21	Q22	Q23	Q24	Q25	Q26	Q27	Q28		
3	3	4	2	3	1	1	2		

NAME: _____ ()

Class: 6 _

SINGAPORE CHINESE GIRLS' SCHOOL
PRIMARY 6 SCIENCE 2022 PRELIMS

Booklet B (44m)

S/N	Recommended Answers
29a	A – stem C – roots
29b	Water, Carbon dioxide
30a	A
30bi	When Rina's speed of running increases, her heart rate increases
30bii	The heart needs to pump more blood / faster to transport more oxygen and more digested food to other parts of the body (as the body needs more energy).
31a	To find out if the clarity of water affects the rate of photosynthesis on aquatic plants.
31b	Oxygen
31c	DRAW: Level of water drawn is higher than Set-up A showing less oxygen produced EXPLAIN: The plant in the muddy water received less light than the one in clear water, thus its rate of <u>photosynthesis was slower, producing less oxygen</u> which was collected in the test tube.
32	a) E b) <pre> graph TD A((A)) --> B((B)) A((A)) --> D((D)) E((E)) --> B((B)) B((B)) --> C((C)) B((B)) --> D((D)) </pre>
33a	The (excessive) pesticides will be <u>washed into the river</u> by rain (and pollutes the water), this will <u>poison/kill/harm</u> the aquatic life in the river.
33b	The roots of the crops will hold the soil together, preventing the soil from being washed into/ running into the river with the rain.
34a	Plant X belongs to Group B - Pod-like structure Plant Y belongs to Group A - Wing-like structure OR Light
34b	Plant Y can be <u>dispersed further away from the parent plant</u> and can <u>reduce overcrowding/</u> competition for light, water, mineral salts and space.
35a	There was <u>air</u> in the the bubble wrap which is a <u>poor conductor of heat</u> . Thus, in Set-up X, <u>heat from the hot water is lost / transferred/ conducted to the surroundings</u> at a <u>slower</u> rate than in Set-up Y (which has no bubble wrap).
35b	When the bird puffs up its feathers, (more) <u>air is trapped between the feathers</u> . <u>Air is a poor conductor of heat</u> , thus with more air between the feathers, it <u>slows down heat conduction/ heat transfer/ heat loss / less heat is lost/ less heat travels from the body to the surroundings</u>
36ai	Potential energy → Kinetic energy → Heat + Sound

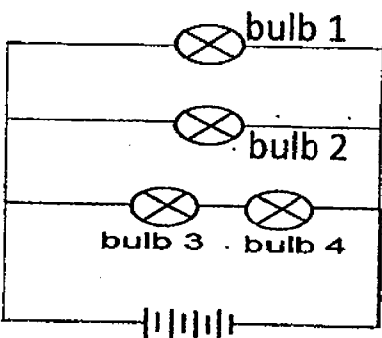
36aii	Y has <u>more mass/ heavier</u> than X, thus Y has <u>more (gravitational) potential energy</u> than X which is converted to <u>more kinetic energy</u> , allowing it to create a deeper dent.
36b	Pot from 14 th floor is at <u>greater height/ higher</u> from the sand pit and thus has <u>more potential energy</u> which is converted to <u>more kinetic energy</u> , enabling it to make a deeper dent in the sand pit.
37ai 37aii	Bulb A: Did not light up Bulb B: Light up B is correctly connected to the wires and the circuit is still a <u>complete/ closed circuit</u> as the <u>metal casing</u> of bulb A is a <u>conductor of electricity</u> .
37b	 <p>Bulb 1 or Bulb 2 when fused must not cause whole circuit to be open</p>
38a	Gravitational force / gravity AND Frictional force/ friction
38b	Car R has <u>rougher surface</u> because it has <u>more tyre threads</u> than Car S so there is <u>more friction between the tyre and the road</u> which enables it to take a shorter distance to come to a stop.
39a	100°C
39b	As the boiling point of water is at 100°C, the <u>highest temperature of the pot will be 100°C</u> . Thus, the chocolate in the inner pot will <u>not reach 175°C</u> and burn.
39c	The <u>warmer/ hotter water vapour/ steam</u> from the boiling water/ water in outer pot came into contact with the <u>cooler outer surface of the inner pot</u> , <u>lost heat</u> and <u>condensed</u> into water droplets. <i>Important to indicate – source of water vapour and surface it condenses</i>
39d	The <u>inner pot</u> is too hot for water vapour to condense on OR The inner pot became <u>almost the same/ similar temperature</u> as the <u>steam/ water vapour</u>
40a	4
40b	Less light is able to reach the datalogger as more light is blocked.
40c	There are no other light sources other than the torch light affecting the results/ the amount of light detected.
41a	Rod P
41b	500g. Silver is non-magnetic/ not a magnetic material.

