

NANYANG PRIMARY SCHOOL

**PRELIMINARY EXAMINATION
2022**

PRIMARY 6

**MATHEMATICS
PAPER 1
(BOOKLET A)**

Total Duration for Booklets A and B: 1 hour

Additional materials: Optical Answer Sheet (OAS)

INSTRUCTIONS TO PUPILS

1. Do not turn over this page until you are told to do so.
2. Follow all instructions carefully.
3. Answer all questions.
4. Shade your answers in the Optical Answer Sheet (OAS) provided.
5. The use of calculators is **NOT** allowed.

Name: _____ ()

Class: Primary 6 ()

Questions 1 to 10 carry 1 mark each. Questions 11 to 15 carry 2 marks each. For each question, four options are given. One of them is the correct answer. Make your choice (1, 2, 3 or 4) and shade your answer on the Optical Answer Sheet. (20 marks)

1 Round 748 850 to the nearest hundred.

(1) 748 800

(2) 748 900

(3) 748 950

(4) 749 000

2 10 hundredths and 75 thousandths is _____

(1) 0.085

(2) 0.175

(3) 0.760

(4) 0.850

- 3 In the number line below, what is the value of Y as indicated by the arrow?

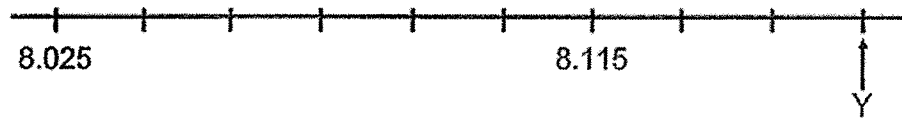

- (1) 8.130
 (2) 8.145
 (3) 8.160
 (4) 8.175
- 4 Which pair of lines in the square grid are parallel?

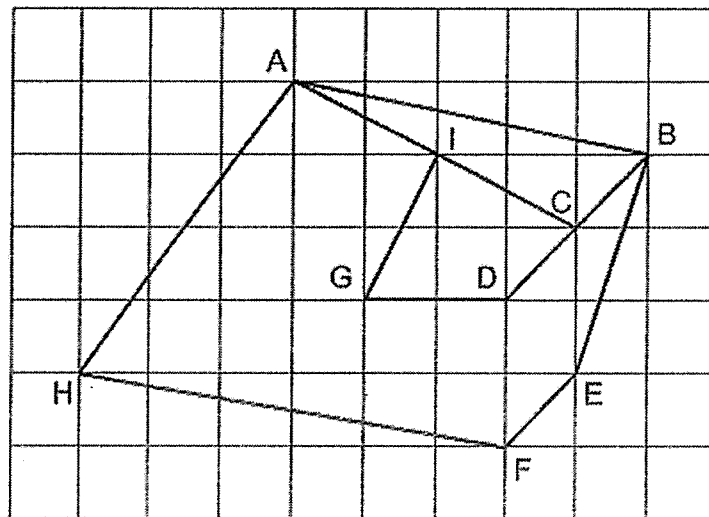

- (1) AH and BE
 (2) GI and AC
 (3) AB and HF
 (4) BD and EF

- 5 BCE and DAB are straight lines. Find $\angle DAC$.

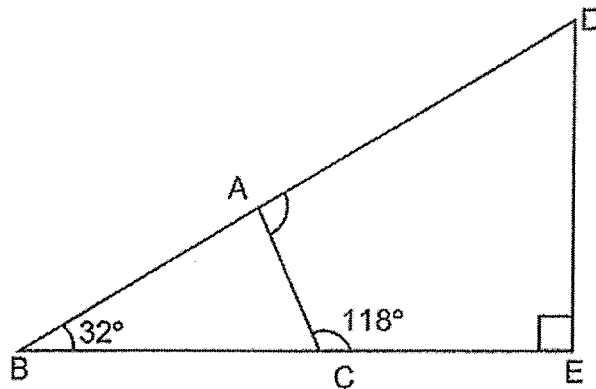

- (1) 148°
 - (2) 94°
 - (3) 86°
 - (4) 62°
- 6 PQRS is a trapezium and RSTU is a parallelogram.

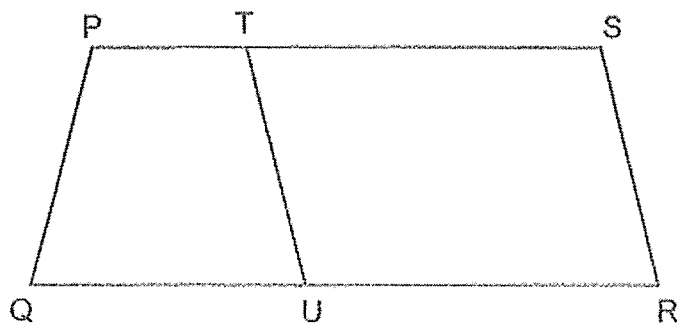

Which of the following pair of angles gives a sum of 180° ?

- (1) $\angle QPT$ and $\angle PTU$
- (2) $\angle TSR$ and $\angle UTS$
- (3) $\angle TUR$ and $\angle TSR$
- (4) $\angle PQU$ and $\angle URS$

7 Which two of the following are nets of a cube?

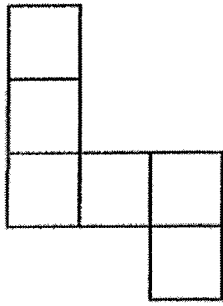

A

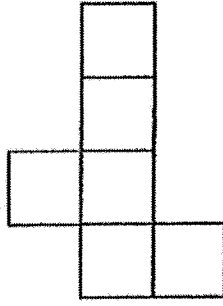

B

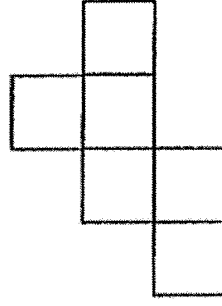

C

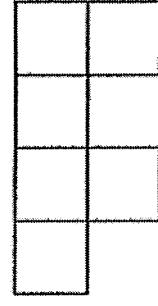

D

- (1) A and B
- (2) A and C
- (3) B and C
- (4) C and D

8 Huiling had \$z. Ravi had twice as much money as Huiling. Jas had \$5 more than Ravi. If Jas had \$10, how much money did Huiling have?

- (1) \$30
- (2) \$7.50
- (3) \$3
- (4) \$2.50

- 9 The pie chart shows the number of four types of drinks sold in the school canteen.

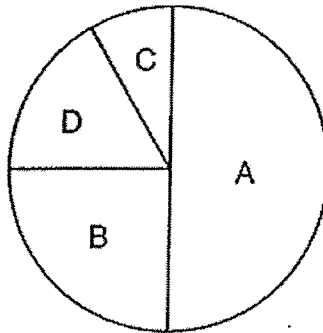

Which bar graph best represents the information in the pie chart?

(1)

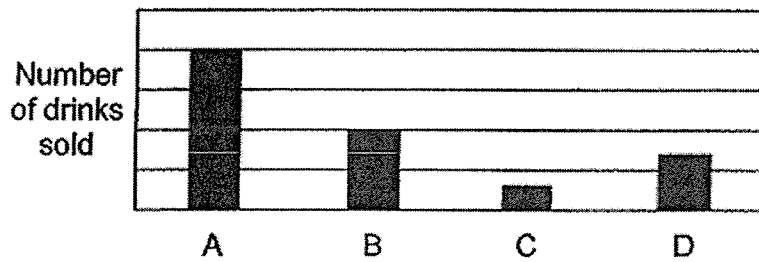

(2)

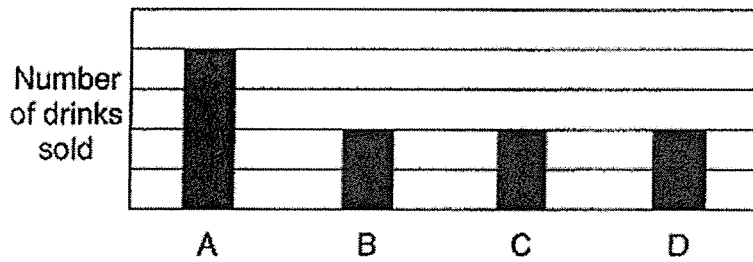

(3)

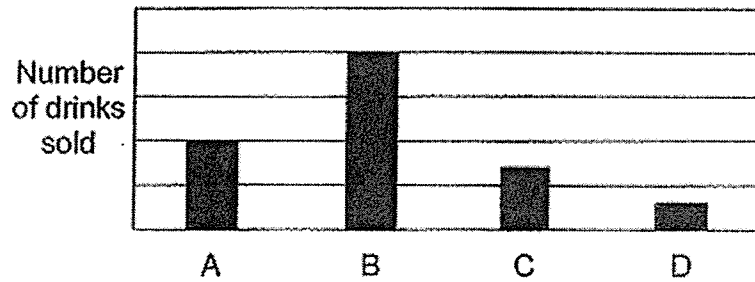

(4)

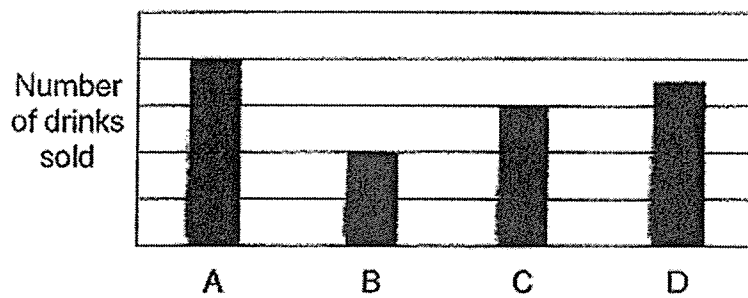

- 10 Which of the following is likely to be the length of a bench in the school canteen?

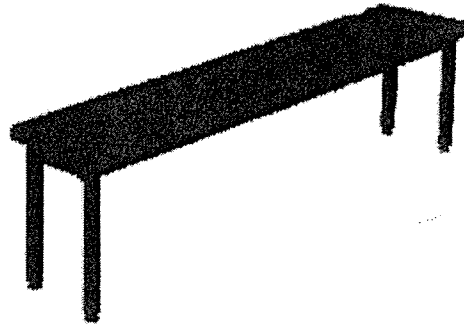

- (1) 1.8 cm
 - (2) 18 cm
 - (3) 1.8 m
 - (4) 18 m
- 11 Which of the following fractions is closest to $\frac{4}{5}$?

- (1) $\frac{3}{5}$
- (2) $\frac{5}{6}$
- (3) $\frac{7}{9}$
- (4) $\frac{9}{10}$

- 12 The square grid shows the positions of the buildings U, V, W, X, Y and Z.

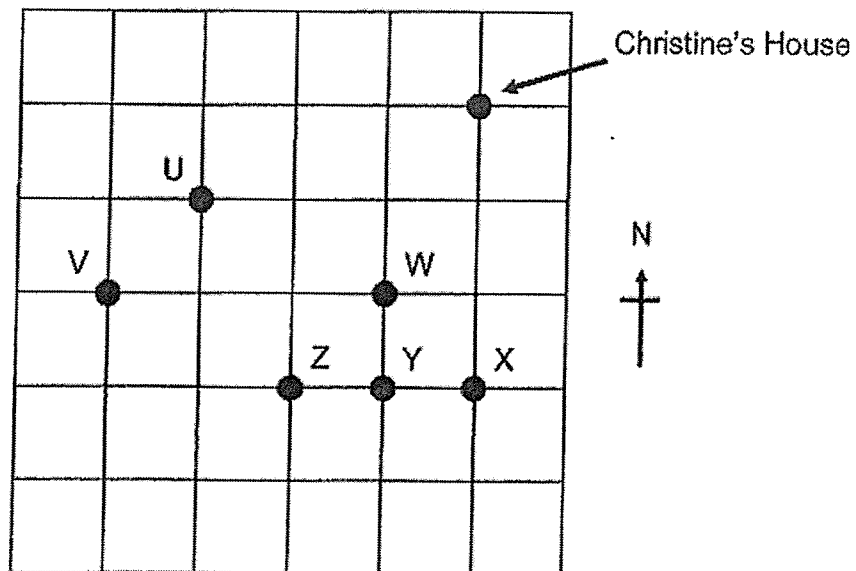

Christine stands at a location south-west of her house and east of a building. When facing south-east from Christine's location, she sees a building. What is that building?

- (1) Building W
- (2) Building X
- (3) Building Y
- (4) Building Z

13 What is the length of the pencil shown below?

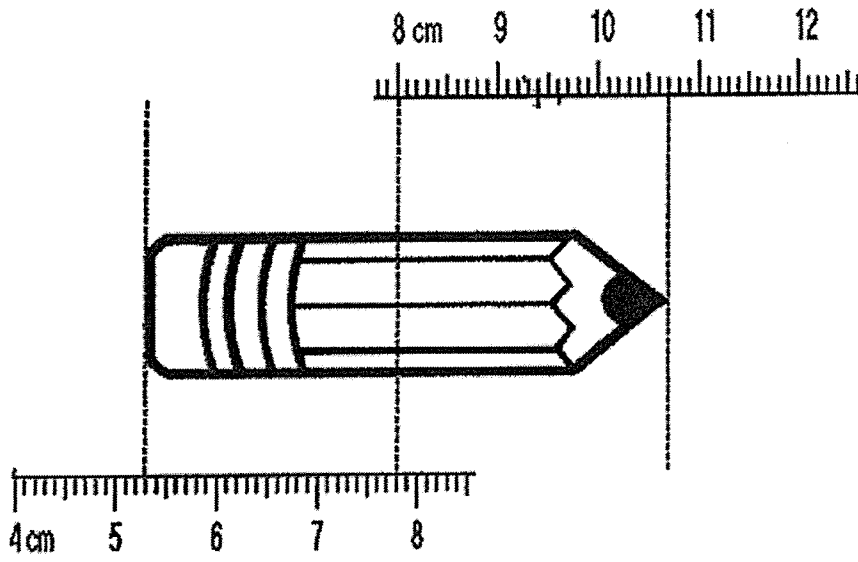

- (1) 5.2 cm
- (2) 5.4 cm
- (3) 5.6 cm
- (4) 10.7 cm

- 14 Viv, Wendy and Xinyi each had some beads. They each used the same number of beads to make a necklace. Viv used $\frac{1}{3}$ of her beads, Wendy used $\frac{7}{8}$ of her beads and Xinyi used $\frac{3}{4}$ of her beads. What was the ratio of the number of beads Viv had at first to the number of beads Wendy had at first to the number of beads Xinyi had at first?

- (1) 1 : 7 : 3
(2) 3 : 8 : 4
(3) 8 : 21 : 18
(4) 63 : 24 : 28

- 15 The first 7 numbers of a number pattern are given below.

4, 16, 8, 32, 16, 64, 32, ...
1st 7th

What is the 13th number?

- (1) 128
(2) 256
(3) 512
(4) 1024



NANYANG PRIMARY SCHOOL

**PRELIMINARY EXAMINATION
2022**

PRIMARY 6

**MATHEMATICS
PAPER 1
(BOOKLET B)**

Total Duration for Booklets A and B: 1 hour

INSTRUCTIONS TO PUPILS

1. Do not turn over this page until you are told to do so.
2. Follow all instructions carefully.
3. Answer all questions.
4. Write your answers in this booklet.
5. The use of calculators is **NOT** allowed.

Name: _____ ()

Class: Primary 6 ()

Booklet B

/ 25

Please sign and return the examination paper the next day. Any queries should be raised at the same time when returning paper.

Questions 16 to 20 carry 1 mark each. Write your answers in the spaces provided. For questions which require units, give your answers in the units stated. (5 marks)

- 16 Mr Ahmad had 2 bags of marbles. One of the bag contained 6 red marbles and 3 blue marbles. The other bag contained 2 red marbles and 4 yellow marbles. What fraction of the total marbles from both bags were red marbles?

Ans: _____

- 17 Find the value of $3.707 \text{ l} + 1.373 \text{ l}$
Express the answer in litres and millilitres.

Ans: _____ l _____ ml

- 18 There are 5 shaded squares in the figure. Shade 5 more squares to form a symmetric figure with XY as the line of symmetry.

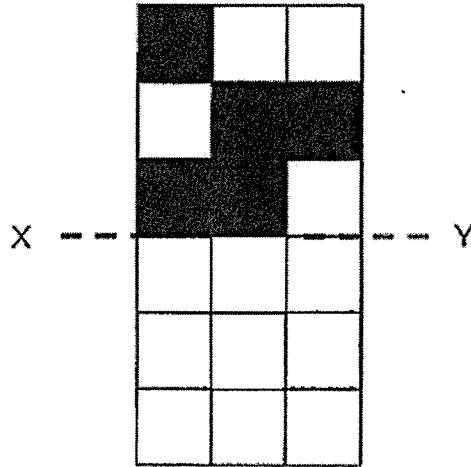

- 19 The solid below is made up of 1-cm cubes. What is the volume of the solid?

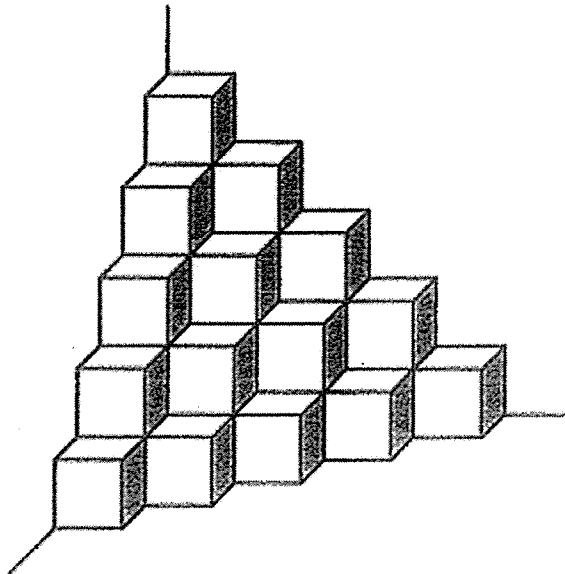

Ans: _____ cm^3

- 20 Paminder stacked 14 unit cubes and glued them together to form the solid below.

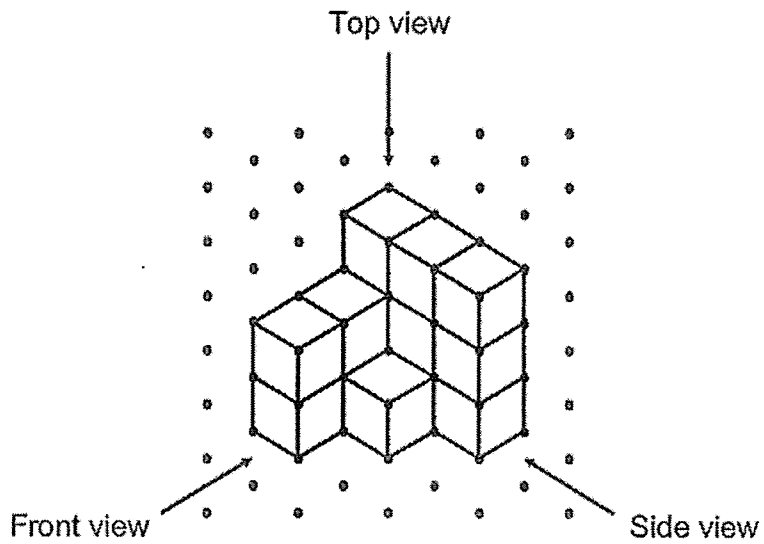

Draw the side view of the solid on the grid below.

Side View

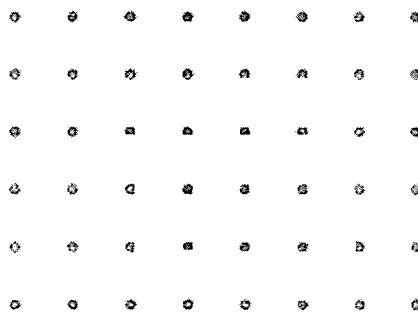

Questions 21 to 30 carry 2 marks each. Show your working clearly and write your answers in the spaces provided. For questions which require units, give your answers in the units stated. (20 marks)

- 21 A faulty traffic light had its red light blinking every 2 seconds, its amber light blinking every 3 seconds and its green light blinking every 8 seconds. If all three lights blink now, how many seconds later will they all blink together again?

Ans: _____ s

22 Mr Liew paid \$78.59 for a pair of shoes and \$19.90 for a towel.

(a) How much did he spend altogether? Round the answer to the nearest dollar.

Ans: (a) \$ _____

(b) Find the cost of 30 such towels.

Ans: (b) \$ _____

23 A day camp lasted 8 h 20 min. The day camp started 1 h 45 min before the snack break. Snack break was at 11.30 a.m. What time did the day camp end? Give your answer in 24-hour clock.

Ans: _____

- 24 In 2021, Maggie saved 20% of her monthly salary of \$3000 each month. In 2022, Maggie received an increase in her monthly salary and she saved \$180 more per month. What was the percentage increase in Maggie's monthly savings?

Ans: _____%

- 25 There were 1338 big buns and 7982 small buns in a factory. The buns were packed into bags. Each bag contained 1 big bun and 6 small buns. What was the greatest number of bags that could be packed?

Ans: _____

- 26 Mrs Chen sold $\frac{1}{3}$ of her apples on Monday. She sold $\frac{2}{3}$ of the remaining apples on Tuesday. Mrs Chen had 14 apples left after selling apples on Monday and Tuesday. How many apples did Mrs Chen have at first?

Ans: _____

- 27 Mary had a roll of ribbon with a total length of 1 m. She cut off $\frac{1}{5}$ m of the ribbon. The remaining length of the ribbon was cut into shorter pieces of length $\frac{1}{8}$ m each. At most, how many pieces of $\frac{1}{8}$ -m long ribbon did Mary have in the end?

Ans: _____

- 28 In the figure below, KLMN is a trapezium and LM is parallel to KN.
 $\angle LMN = 48^\circ$ and $\angle MNK$ is $\frac{3}{2}$ times of $\angle MLK$. Find $\angle MLK$.

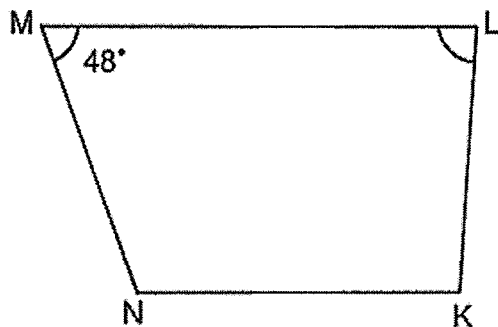

Ans: _____^o

- 29 ABEF and BCDE are parallelograms. $\angle FAB = 114^\circ$ and $\angle EBC = 78^\circ$.
 Find $\angle DEF$.

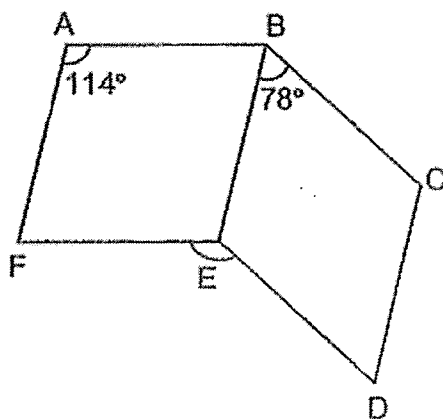

Ans: _____^o

- 30 Pam Bakery uses m kg of sugar each month. Pam Bakery uses 30 kg more sugar than Sweet Bakery each month. If $m = 100$, how many kilograms of sugar do Pam Bakery and Sweet Bakery use in total for one year?

Ans: _____ kg

End of Paper



NANYANG PRIMARY SCHOOL

**PRELIMINARY EXAMINATION
2022**

**PRIMARY 6
MATHEMATICS
PAPER 2**

Duration: 1 hour 30 minutes

INSTRUCTIONS TO PUPILS

1. Do not turn over this page until you are told to do so.
2. Follow all instructions carefully.
3. Answer all questions.
4. Write your answers in this booklet.
5. The use of an approved calculator is allowed.

Name: _____ ()

Class: Primary 6 ()

Parent's Signature: _____

Booklet A	/ 20
Booklet B	/ 25
Paper 2	/ 55
Total	/ 100

Please sign and return the examination paper the next day. Any queries should be raised at the same time when returning paper.

Questions 1 to 5 carry 2 marks each. Show your working clearly and write your answers in the spaces provided. For questions which require units, give your answers in the units stated. (10 marks)

- 1 The original price of a book was \$ k . David bought 15 such books. After he was given a discount of \$10, he paid a total of \$110. What was the original price of one such book?

Ans: \$ _____

- 2 The table below shows the charges for renting a bicycle.

	Days	Time	Charge
	Mon to Fri	7 a.m. to 5 p.m.	\$4 per hour
		5 p.m. to 9 p.m.	\$8 per hour
Sat and Sun	7 a.m. to 9 p.m.	\$12 per hour	

On Friday, Mr Wu rented a bicycle and returned it at 6 p.m. He paid a total of \$24. For how many hours did he rent the bicycle?

Ans: _____ h

- 3 Ji Min saved some money in April. She saved \$2.50 per day for 20 days. She then saved \$3.10 per day for the rest of the month. What was the average amount of money she saved per day in April? (There are 30 days in April.)

Ans: \$ _____

- 4 Dana bought an oven from Shop A at 15% discount during a sale. The price of the oven was \$800 before discount at Shop A. Hailey bought an identical oven from Shop B at 20% discount and paid the same amount as Dana. What was the price of the oven before discount at Shop B?

Ans: \$ _____

- 5 The figure is formed by 5 straight lines DF, EH, EG, FH and DG. Find $\angle EHF$.

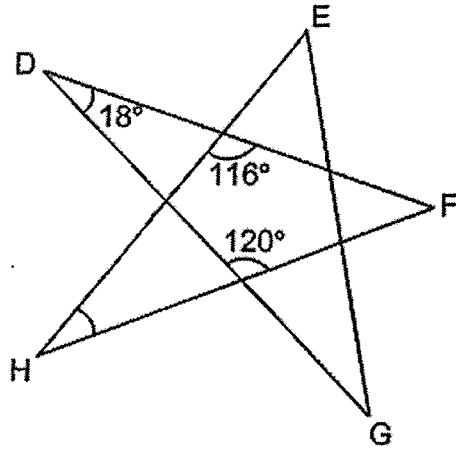

Ans: _____^o

For questions 6 to 17, show your working clearly and write your answers in the spaces provided. The number of marks available is shown in brackets [] at the end of each question or part-question. (45 marks)

- 6 In the square grid below, AB and BC are straight lines.
- (a) AB and BC form two sides of a rhombus ABCD. Complete the drawing of the rhombus ABCD. [1]
- (b) AB also forms one side of a trapezium ABEF. AB is parallel to EF. The length of EF is twice the length of AB. DAF forms a straight line and $AD = AF$. Complete the drawing of trapezium ABEF such that it does not overlap with the rhombus. [2]

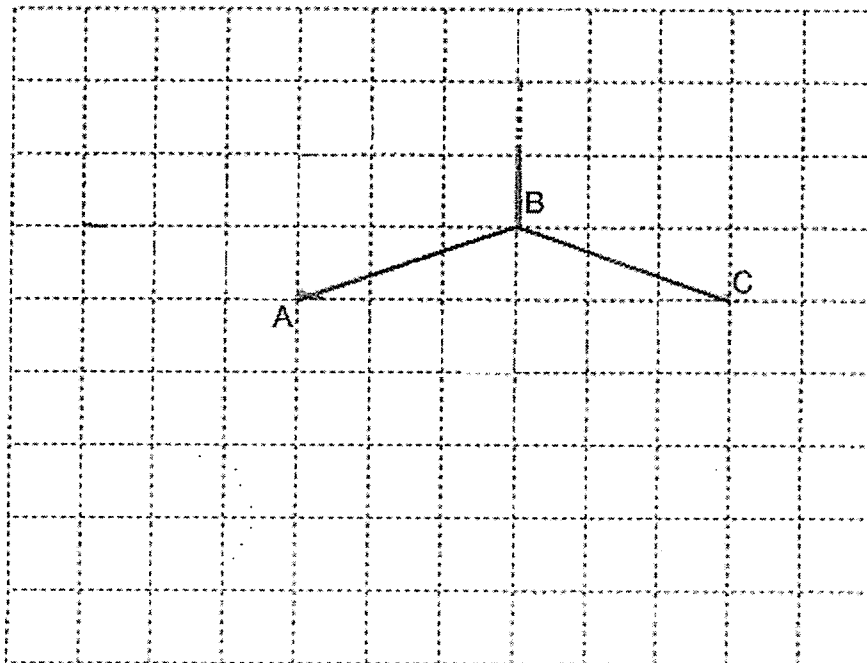

- 7 Peter had \$18.20 less than Jane at first. After Jane gave some of her money to Peter, he had \$29.20 more than her. How much money did Jane give to Peter?

Ans: _____ [3]

- 8 Kira had a roll of blue paper and a roll of red paper. The length of the roll of blue paper is $\frac{1}{2}$ the length of the roll of red paper. She cut the roll of blue paper into equal parts of length 9 cm and on each part she drew 3 star shapes. After that, she cut the roll of red paper into equal parts of length 7 cm and on each part she drew 5 heart shapes. What fraction of the shapes Kira drew were star shapes?

Ans: _____ [3]

- 9 Four towns A, B, C and D collected plastic bottles to be recycled. Town A and B collected an average of 324 plastic bottles. Town B, C and D collected an average of 344 plastic bottles. The total number of plastic bottles collected by all 4 towns was 6 times the number that town B collected. How many plastic bottles did town B collect?

Ans: _____ [3]

- 10 Mr Toh left Town B and drove to Town C at 11 a.m. at a constant speed of 60 km/h. Mr Lee left Town A at 12 noon and drove to Town C at a constant speed of 80 km/h. Town A and Town B were 15 km apart. After travelling from Town A to Town B, Mr Lee then travelled to Town C along the same route as Mr Toh. At what time did Mr Lee catch up with Mr Toh?



Ans: _____ [3]

- 11 Tank Y and Tank Z are two rectangular tanks. At first, Tank Y contained some water to a height of 42 cm and Tank Z was empty.

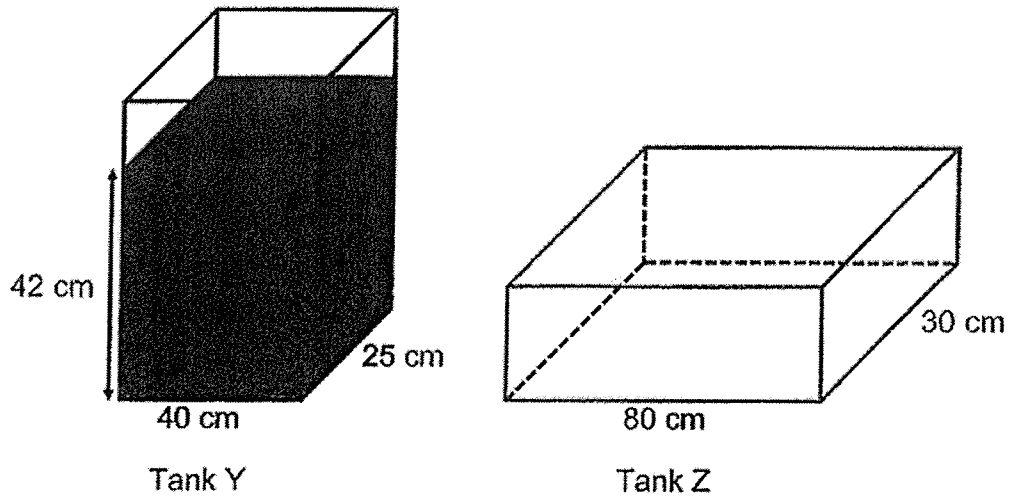

- (a) What was the volume of the water in Tank Y at first?

Ans: (a) _____ [1]

- (b) Kanthea poured some water from Tank Y into Tank Z. After that, Tank Y had $\frac{2}{5}$ as much water as Tank Z. Find the height of the water level in Tank Z.

Ans: (b) _____ [3]

- 12 A rectangular block A was cut along the dotted line into two smaller rectangular blocks of equal height, B and C, as shown below. The volume of block B was 4752 cm^3 less than that of block C.

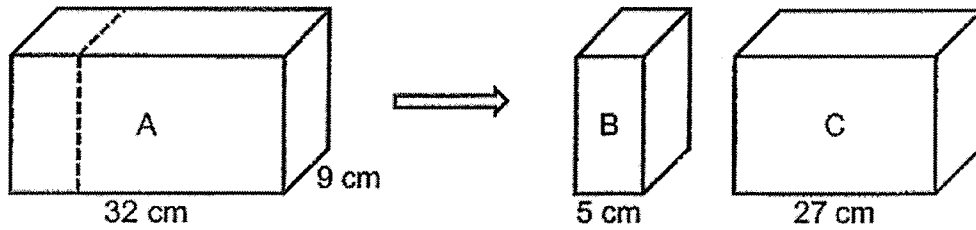

- (a) What was the height of each block?

Ans: (a) _____ [2]

- (b) Matthias packed 12 of block C such that they fit exactly into a box with a square base. The box had the same height as block C. At most, how many of block B can be packed into such a box?

Ans: (b) _____ [2]

- 13 JI Eun filled a tank with water using two taps, Tap A and Tap B. She turned on Tap A first. After 10 minutes, she turned on Tap B. Both taps were turned off at the same time when the tank was completely filled. The graph below shows the amount of water in the tank over 45 minutes.

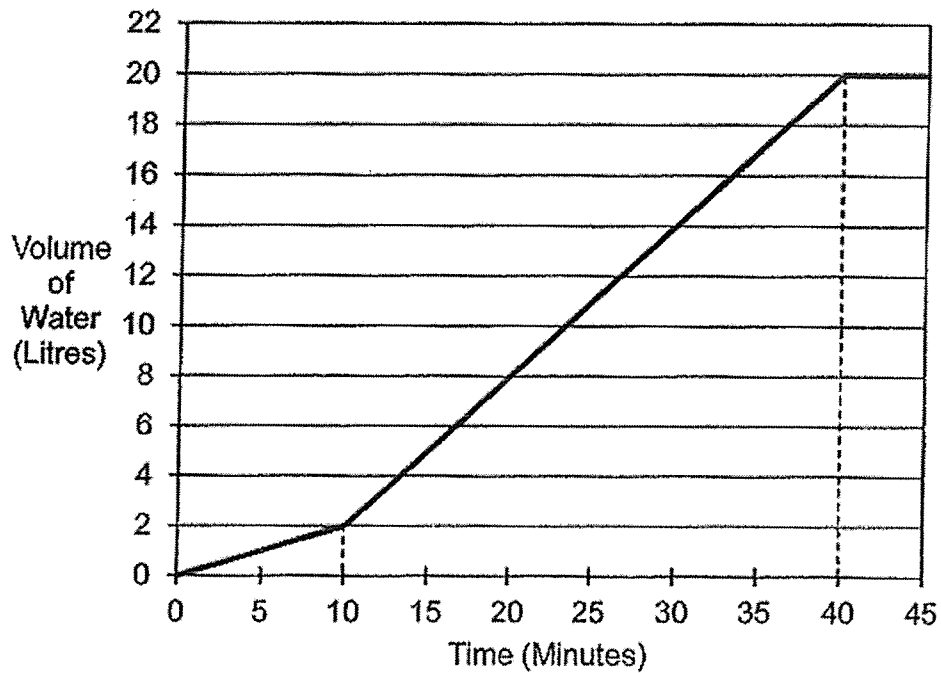

- (a) What was the capacity of the tank?

Ans: (a) _____ [1]

- (b) How many litres of water flowed from Tap B per minute?

Ans: (b) _____ [3]

14 Marlam had some gold, some silver and some copper tokens for a carnival. The ratio of the number of gold tokens to the total number of silver and copper tokens was $10 : 9$. The ratio of the number of silver tokens to the number of copper tokens was $3 : 1$. She exchanged 12 gold tokens for a stuffed toy and some silver tokens for a jar of marbles. In the end, the ratio of the number of gold tokens to the number of copper tokens became $4 : 1$ and the ratio of the number of silver tokens to the number of copper tokens became $4 : 3$.

(a) What was the ratio of the number of gold tokens to the number of silver tokens to the number of copper tokens Marlam had at first?

Ans: (a) _____ [1]

(b) How many silver tokens did Marlam exchanged for the jar of marbles?

Ans: (b) _____ [3]

- 15 ABC is a triangular piece of paper with $AB = AC$. $\angle BAC = 95^\circ$. AEB and BDC are straight lines. The paper is then folded along the line DE as shown below.

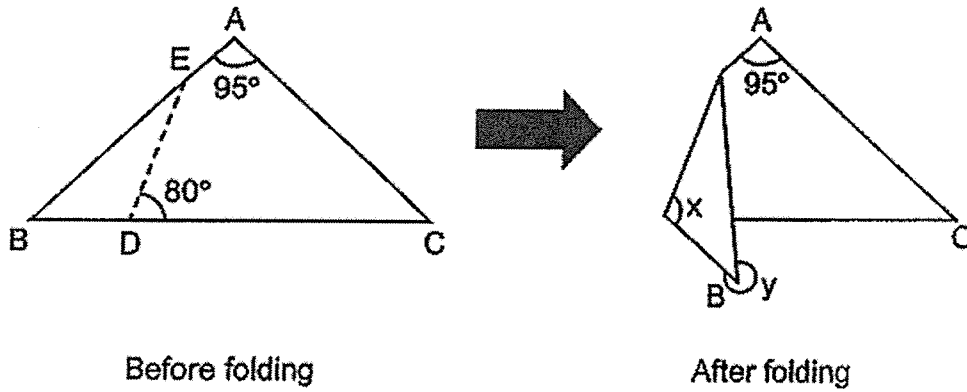

(a) Find $\angle x$.

Ans: (a) _____ [2]

(b) Find $\angle y$.

Ans: (b) _____ [2]

- 16 A shop sells four types of muffin. The bar graph shows the number of each type of muffin sold by the shop. The bar for the number of banana muffins sold has not been drawn. The number of banana muffins sold was $\frac{3}{5}$ the number of vanilla muffins sold.

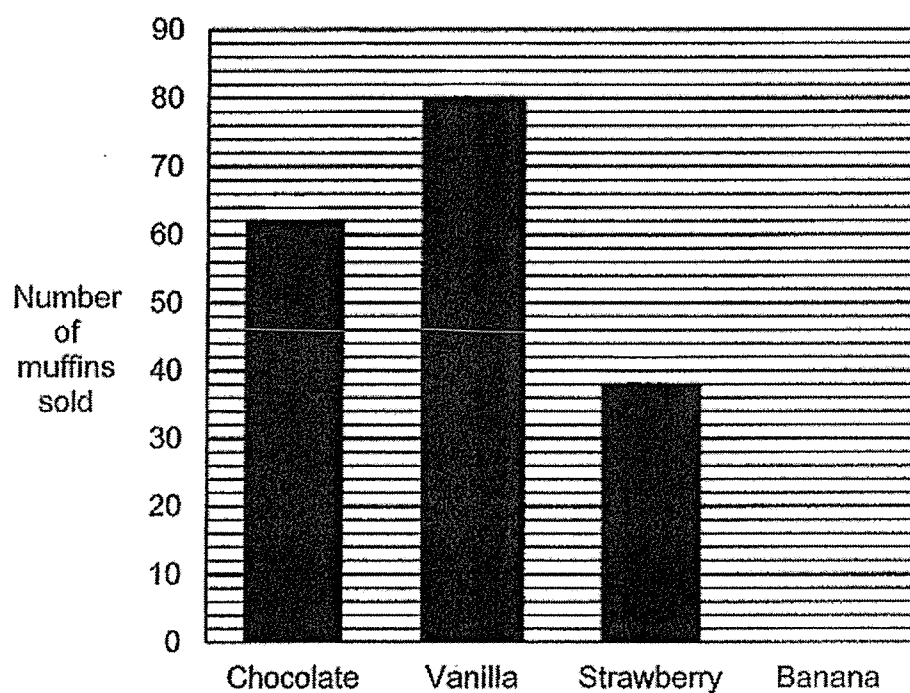

- (a) How many banana muffins were sold?

Ans: (a) _____ [1]

(b) The table below shows the prices of the muffins.

Type of muffin	Price per muffin
Chocolate	\$0.85
Vanilla	\$0.70
Strawberry	\$1.35
Banana	\$1.20

From the sales of which type of muffin did the shop collect the most money? What was the amount of money?

Ans: (b) Muffin: _____

Amount: _____ [2]

(c) Each of the statements below is either true, false or not possible to tell from the information given. For each statement, put a tick (✓) to indicate your answer.

Statement	True	False	Not possible to tell
The number of chocolate muffins sold was 62.			
The ratio of the number of strawberry muffins sold to the number of strawberry muffins left unsold was 3 : 2.			
The shop sold 46 boxes of 5 muffins.			

[2]

- 17 The figure below is made up of a semicircle, 2 identical quarter circles and 2 identical right-angled isosceles triangles, ACB and ACD . $CA = CB = CD$. O is the centre of the circle. AOC and BCD are straight lines. Find the total area of the shaded parts.
(Take $\pi = 3.14$)

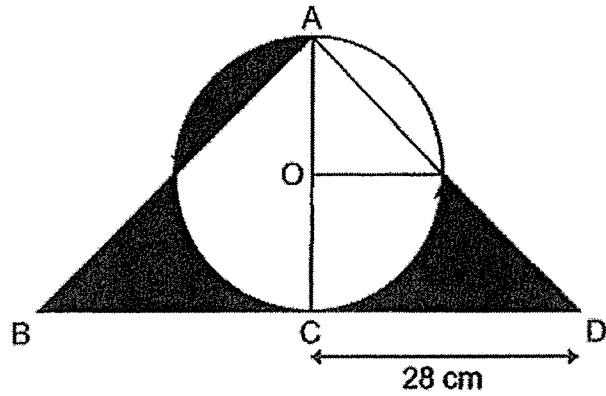

Ans: _____ [5]

End of Paper

Nanyang 2022 Prelims Paper 1

Q1. (2) Q2. (2) Q3. (3) Q4. (4) Q5. (2)
Q6. (2) Q7. (3) Q8. (4) Q9. (1) Q10. (3)
Q11. (3) Q12. (3) Q13. (1) Q14. (4) Q15. (2)

Q16. $\frac{\text{Red}}{\text{total}} = \frac{6+2}{6+3+2+4} = \frac{8}{15}$

Q17. $3.707 + 1.373 = 5.080$
 $5.080\text{e} = \underline{\underline{5\text{e}80\text{ml}}}$

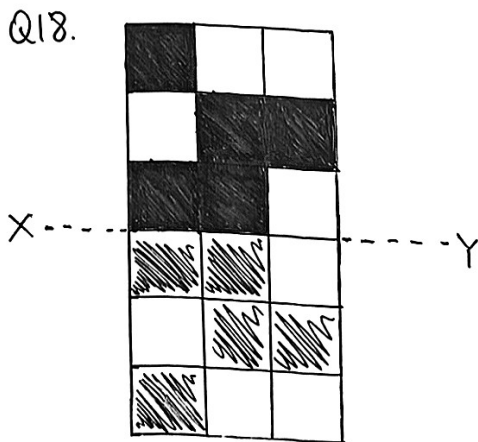

Q19. 35

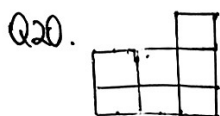

Q21. $\text{LCM}(2, 3, 8) = \underline{\underline{24}}$

Q22(a) $78.59 + 19.90 = 98.49$

$98.49 \approx \underline{\underline{98}}$

(b) $19.90 \times 30 = \underline{\underline{597}}$

Q23.

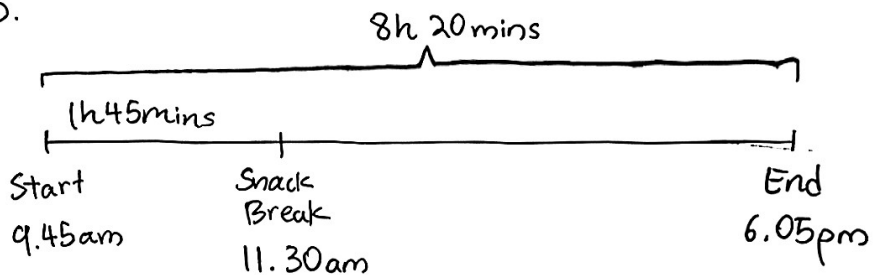

6.05 pm in 24 hour clock $\underline{\underline{18 05}}$

Q24. $3000 \times 20\% = 600$

$\frac{180}{600} \div 100\% = \underline{\underline{30\%}}$

Q25. $7982 \div 6 = \underline{\underline{1330R2}}$

Q26.	Monday	Tuesday	Remaining	Total
	3u	4u	2u	9u
	2u=14	1u=7	7x9= <u>63</u>	

Q27. $1 - \frac{1}{5} = \frac{4}{5}$

$$\begin{aligned} \frac{4}{5} \div \frac{1}{8} &= \frac{4}{5} \times 8 \\ &= \frac{32}{5} \\ &= 6\frac{2}{5} \end{aligned}$$

$$6\frac{2}{5} \approx \underline{\underline{6}}$$

Q28. $\angle MNK = 180^\circ - 48^\circ = 132^\circ$

$$\angle MLK = 132^\circ \div 3 \times 2 = \underline{\underline{88^\circ}}$$

Q29. $\angle BEF = \angle FAB = 114^\circ$

$$\angle BED = 180^\circ - 78^\circ = 102^\circ$$

$$\angle DEF = 360^\circ - 114^\circ - 102^\circ = \underline{\underline{144^\circ}}$$

Q30. $100 - 30 = 70$

$$(100 + 70) \times 12 = 170 \times 12 = \underline{\underline{2040}}$$

Nanyang 2022 Prelim Paper 2

Q1. $110 + 10 = 120$

$$120 \div 15 = \underline{8}$$

Q2. $24 - 8 \times 1 = 16$

$$16 \div 4 = 4$$

$$4 + 1 = \underline{5}$$

Q3. $2 \cdot 50 \times 20 + 3 \cdot 10 \times 10 = 50 + 31 = 81$

$$81 \div 30 = \underline{\underline{2.70}}$$

Q4.

	Shop A	Shop B
Before Discount	80u	85u
After Discount	68u	68u

$$80u = 800 \quad 1u = 10 \quad 85 \times 10 = \underline{\underline{850}}$$

Q5. $\angle DFH = 180^\circ - 18^\circ - 120^\circ = 42^\circ$

$$\angle EHF = 180^\circ - 116^\circ - 42^\circ = \underline{\underline{22^\circ}}$$

Q6.

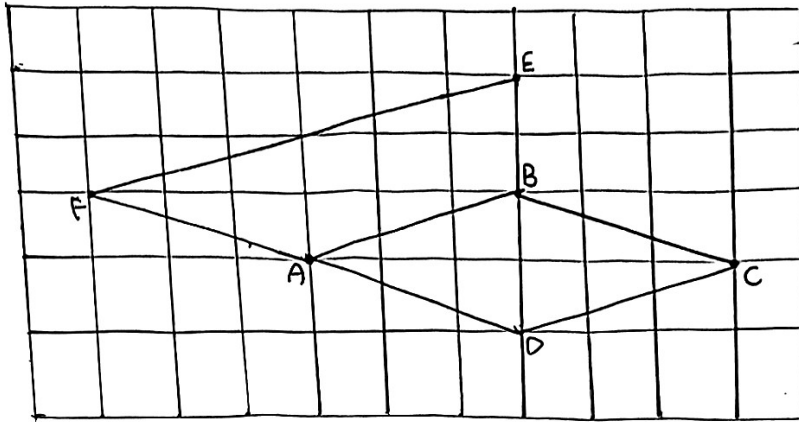

Q7. $18.20 + 29.20 = 47.40$

$47.40 \div 2 = \underline{23.70}$

Q8. Blue Red
 63u 126u

$63u \div 9 = 7u$

$7u \times 3 = 21u$

$126u \div 7 = 18u$

$18u \times 5 = 90u$

$21u + 90u = 111u$

$\frac{21u}{111u} = \underline{\underline{\frac{7}{37}}}$

Q11(a) $42 \times 40 \times 25 = 42 \times 1000 = \underline{\underline{42000}}$

(b)

	Tank Y	Tank Z	Total
Before	$7u$	0	$7u$
After	$2u$	$5u$	$7u$

$7u = 42000$

$1u = 6000$

$5 \times 6000 = 30000$

$30000 \div (80 \times 30) = 30000 \div 2400 = \underline{\underline{12.5}}$

Q12(a) $(27 - 5) \times 9 = 12 \times 9 = 108$

$4752 \div 108 = \underline{\underline{44}}$

(b)

54		
27	27	9
		9
		9
		9
		9
		9
		9
		9

54

$54 \div 9 = 6$

$54 \div 5 = 10$

$6 \times 10 = \underline{\underline{60}}$

Q13 (a) 20%

$$(b) \frac{2}{10} = 0.2$$

$$\frac{20-2}{40-10} = \frac{18}{30} = \frac{6}{10} = 0.6$$

$$0.6 - 0.2 = \underline{\underline{0.4}}$$

Q14 (a)	Gold	Silver	Copper
At first	40u	27u	9u
	-12		
End	36u	12u	9u

$$\underline{\underline{40:27:9}}$$

$$(b) 40u - 12 = 36u$$

$$4u = 12$$

$$1u = 3$$

$$27u - 12u = 15u$$

$$15 \times 3 = \underline{\underline{45}}$$

$$\text{Q15(a)} \quad \angle x = 180^\circ - 80^\circ = \underline{\underline{100^\circ}}$$

$$\text{(b)} \quad \angle ABC = (180^\circ - 95^\circ) \div 2 = 85^\circ \div 2 = 42.5^\circ$$

$$\angle y = 360^\circ - 42.5^\circ = \underline{\underline{317.5^\circ}}$$

$$\text{Q16(a)} \quad 80 \times \frac{3}{5} = \underline{\underline{48}}$$

$$\text{(b)} \quad 62 \times 0.85 = 52.70$$

$$80 \times 0.70 = 56$$

$$38 \times 1.35 = 51.30$$

$$48 \times 1.20 = 57.60$$

Muffin: Banana

Amount: \$57.60

(c) True

False

False

$$Q17. OA = 28 \div 2 = 14$$

$$3.14 \times 14^2 \div 4 - 14 \times 14 \div 2 = 55.86$$

$$(28 + 56) \times 14 \div 2 - 3.14 \times 14^2 \div 2 = 280.28$$

$$55.86 + 280.28 = \underline{\underline{336.14}}$$