



AI TONG SCHOOL

2022 END-OF-YEAR EXAMINATION PRIMARY FIVE SCIENCE

(BOOKLET A)

27 OCTOBER 2022

Total time for booklets A and B : 1 h 45 min

INSTRUCTIONS

Do not turn over this page until you are told to do so.

Follow all instructions carefully.

Answer all questions.

Name : _____ ()

Class : Primary 5 _____

Parent's Signature : _____

Booklet A	56
Booklet B	44
Total	100

Section A (28 x 2 marks)

For each question from 1 to 28, four options are given. One of them is the correct answer. Make your choice and shade the correct oval (1, 2, 3 or 4) on the Optical Answer Sheet.

1. The diagrams show two animals.

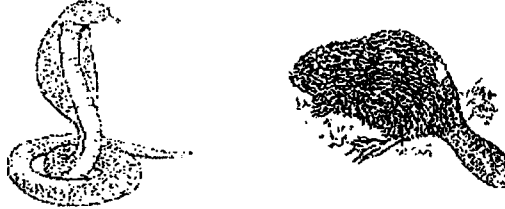

How are the animals similar?

- (1) have fur
 (2) have dry skin
 (3) breathe through lungs
 (4) reproduce by laying eggs
2. The table below shows some information on three cells, D, E and F.
 A tick (✓) indicates the presence of the part of a cell.

Part	Cell D	Cell E	Cell F
Cell Membrane	✓	✓	✓
Nucleus		✓	✓
Chloroplasts		✓	
Cell Wall		✓	✓
Cytoplasm	✓	✓	✓

Fatimah wrote some statements about the cells.

- A Cells D, E and F can reproduce.
 B Only Cell D has an irregular shape.
 C Cell E and Cell F come from the same part of the plant.

Which of her statement(s) is/are correct?

- (1) B only
 (2) A and B only
 (3) A and C only
 (4) A, B and C

3. A group of scientists recently discovered a glowing organism in the ocean. They took out the part that helps it to glow and put it into a plant cell, hoping to get a young plant that produces light.

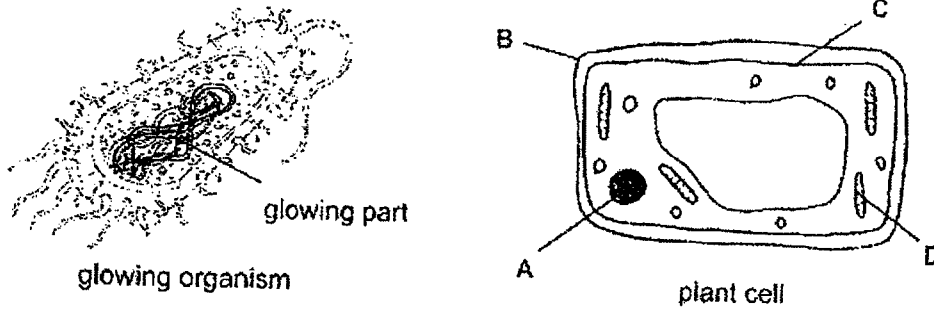

Where should the scientists insert the glowing part?

- (1) A
 (2) B
 (3) C
 (4) D
4. The diagram below shows the fruits of a plant.



Which of the following statements about Z are true?

- A They help in dispersal.
 B They can grow into new plants.
 C They are the pollen grains of the flower.
 D They are formed from the ovules of the flower.
- (1) A and C only
 (2) A and D only
 (3) B and C only
 (4) B and D only

5. The map below shows the distribution of four plants, represented by ■, ●, ▲ and ★.

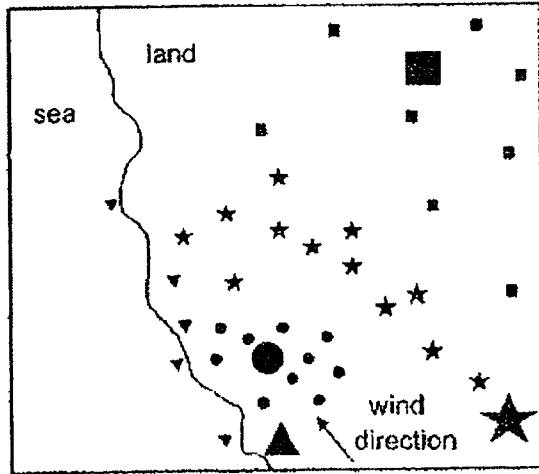

Legend

Parent	Young
★	★
■	■
●	●
▲	▲

How are the plants most likely to be dispersed?

	●	■	★	▲
(1)	animal	splitting	water	wind
(2)	splitting	animal	wind	water
(3)	water	animal	wind	splitting
(4)	wind	splitting	water	animal

6. The diagram below shows the life cycle of a flowering plant.

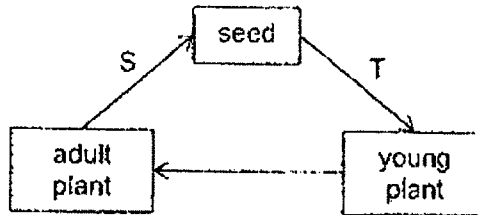

Which of the following shows the correct processes taking place at S and T?

	S	T
(1)	germination and fertilisation	pollination and seed dispersal
(2)	pollination and fertilisation	seed dispersal and germination
(3)	fertilisation and seed dispersal	germination and pollination
(4)	seed dispersal and germination	pollination and fertilisation

7. The diagram below shows the movement of blood in the human circulatory system.



Blood was drawn from the four different blood vessels, P, Q, R and S, in the body. The graph below shows the amount of oxygen in the four blood samples.

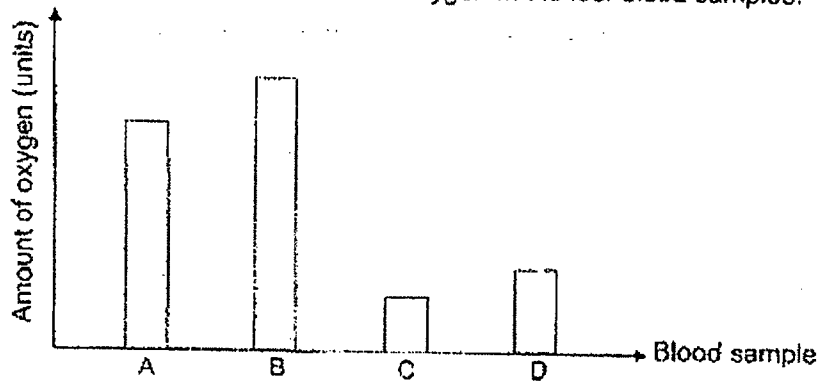

Based on the graph above, which one of the blood samples was taken from vessel S of the circulatory system shown in the diagram above?

- (1) Blood sample A
- (2) Blood sample B
- (3) Blood sample C
- (4) Blood sample D

8. The cross-sections of the stem of plants H and J are shown below.

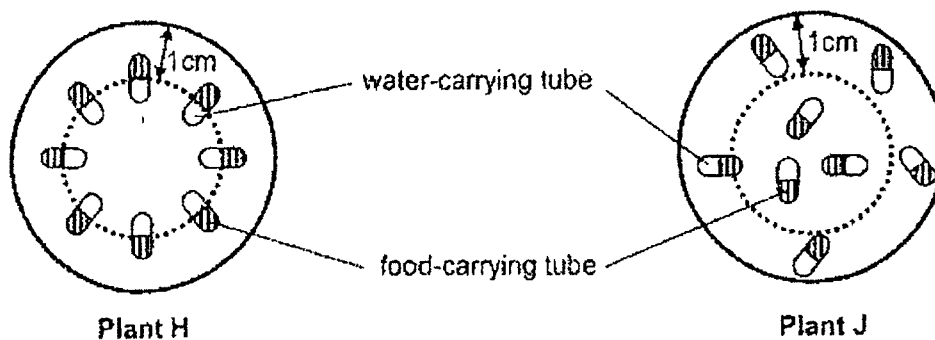

Nicholas removed 1 cm around each stem and put the plants into beakers of water. The amount of water in each container is the same at the start of the experiment.

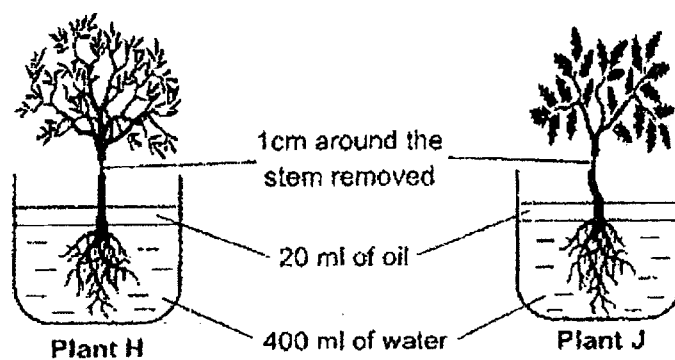

Which of the following results will Nicholas observe after five days?

	Amount of water left in container with plant H (ml)	Amount of water left in container with plant J (ml)
(1)	350	350
(2)	350	370
(3)	370	350
(4)	400	400

9. Clara placed half of a split celery stalk into a beaker containing red-coloured water and the other half of the stalk into a beaker containing blue-coloured water. After a few hours, she cut across at positions X, Y and Z, as shown below.

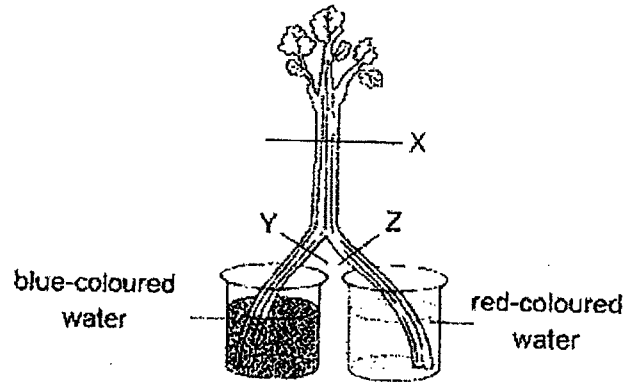

She noticed that the cross-section cuts at X, Y and Z contained coloured dots.



Which one of the following shows the possible colours of the dots at X, Y and Z?

	X	Y	Z
(1)	purple	blue	red
(2)	purple	red	blue
(3)	red and blue	red	blue
(4)	red and blue	blue	red

10. The diagram below shows the respiratory systems of a fish and a human.

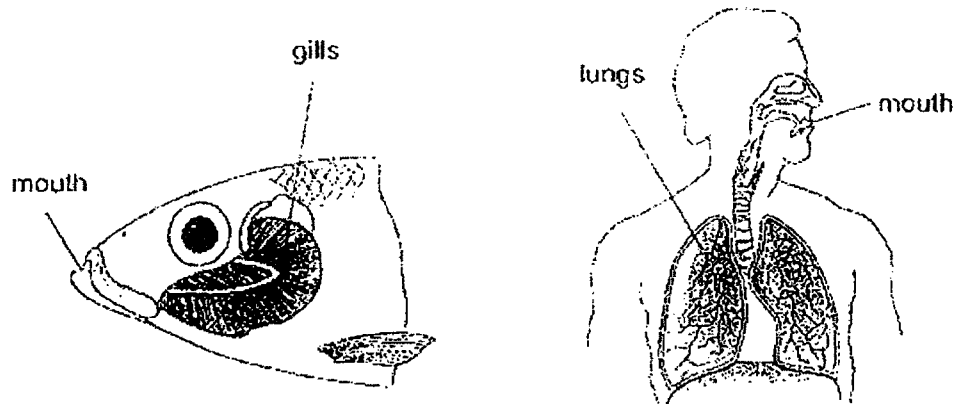

How are the respiratory systems similar?

- A Both the gills and lungs take in air from the surroundings.
- B Both the gills and lungs remove carbon dioxide from the body.
- C Both the fish and human remove carbon dioxide through their mouths.

- (1) A and B only
- (2) A and C only
- (3) B and C only
- (4) A, B and C

11. Karen wanted to find out if dead maggots produce carbon dioxide. She placed a few dead maggots in an empty container and attached it with a connecting tube to a container of liquid X as shown below. Liquid X turns chalky in the presence of carbon dioxide.

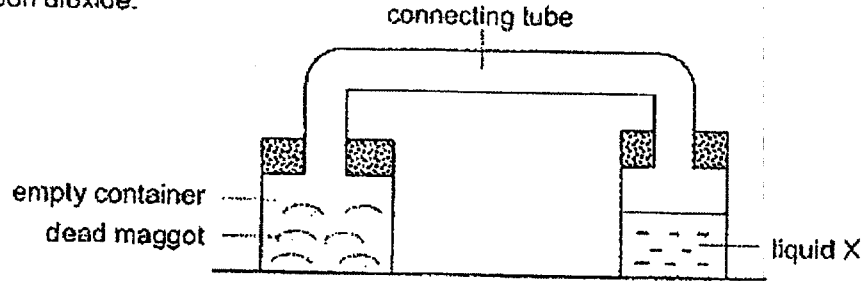

Which of the following set-ups could be used as a control for Karen's experiment?

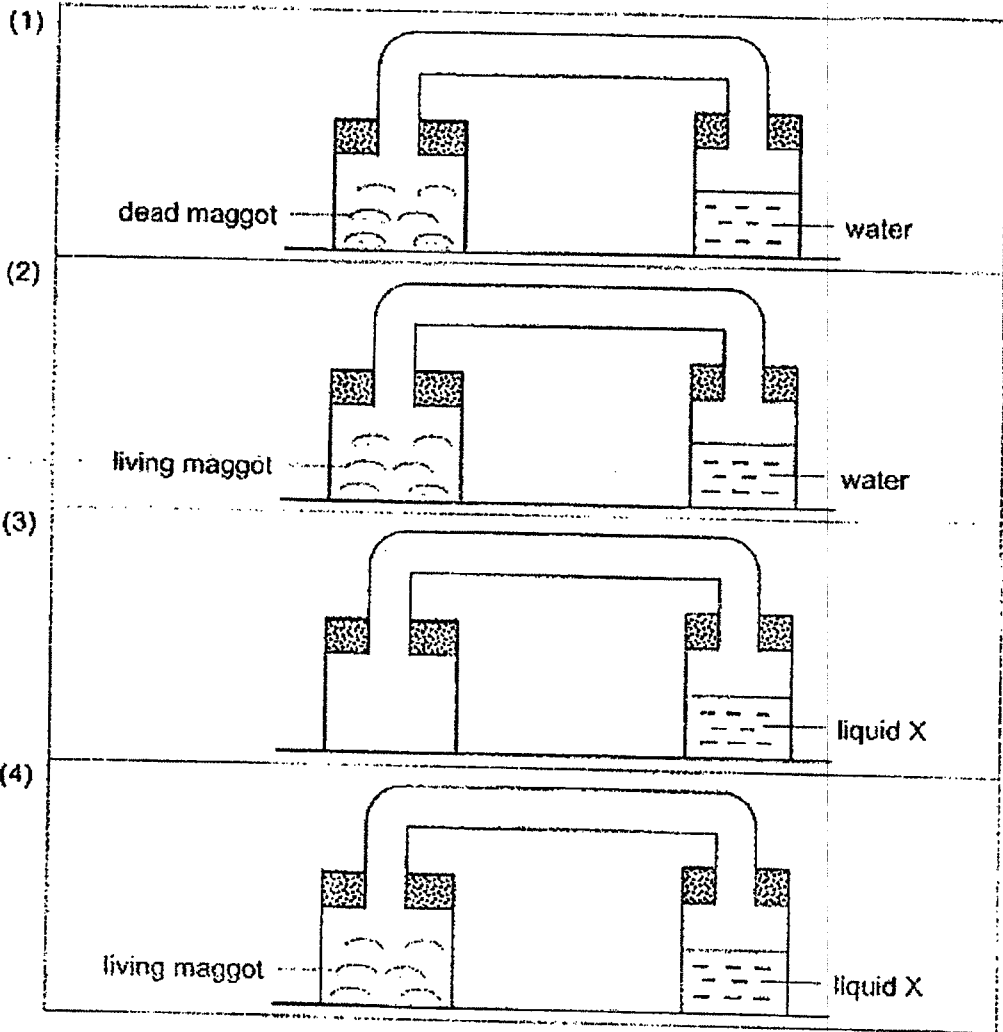

12. Hasim had a glass jar containing a water plant immersed in the water. He placed the jar at a distance x cm from a lamp as shown in the diagram below. The experiment was carried out in a dark room.

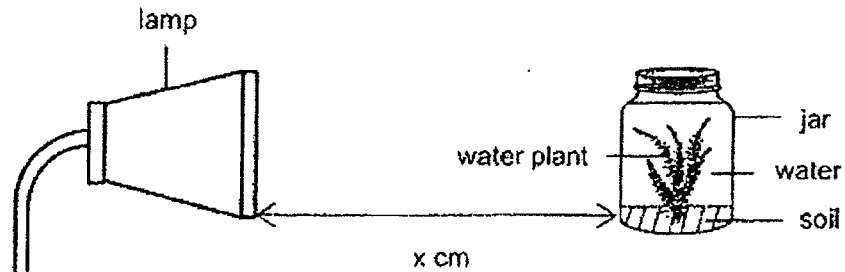

He switched on the lamp and counted the number of bubbles produced by the water plant in one minute. He repeated the experiment by placing the jar at y cm and z cm from the lamp and the results are shown in the table below.

Distance between the jar and the lamp (cm)	Number of bubbles produced by the water plant in one minute
x	19
y	11
z	29

Which one of the following correctly represents distances x , y and z ?

	Distance between the jar and the lamp (cm)		
	x	y	z
(1)	5	19	10
(2)	10	5	19
(3)	19	10	5
(4)	10	19	5

13. Andrew took a leaf and placed it in the dark for two days.

After two days, he did the following to the leaf:

- sealed Part C of the leaf with a plastic bag and added substance A into the plastic bag
- covered Part D with a piece of black paper
- left Part E untouched

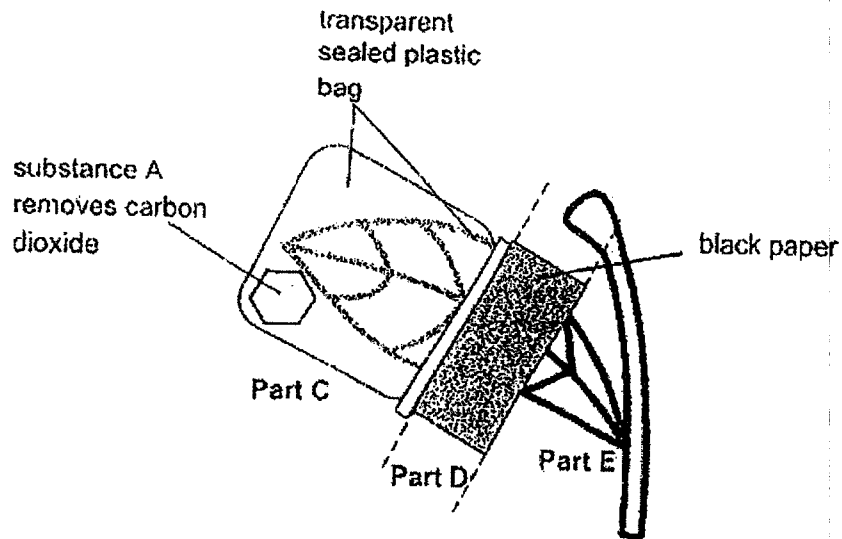

Andrew then placed the leaf under sunlight for a few hours and tested for starch with iodine solution. Iodine turns dark blue when starch is present.

Which one of the following shows the correct observations?

	Part C	Part D	Part E
(1)	iodine turned dark blue	iodine turned dark blue	iodine remained yellowish brown
(2)	iodine remained yellowish brown	iodine turned dark blue	iodine remained yellowish brown
(3)	iodine turned dark blue	iodine remained yellowish brown	iodine turned dark blue
(4)	iodine remained yellowish brown	iodine remained yellowish brown	iodine turned dark blue

14. David observed the properties of four materials, P, Q, R and S. He recorded his observations in the table below. A tick (✓) shows that the material has the property.

Material	Flexible	Strong	Waterproof
P		✓	✓
Q	✓	✓	✓
R	✓		
S		✓	

The diagram below shows a tent made of parts A and B.

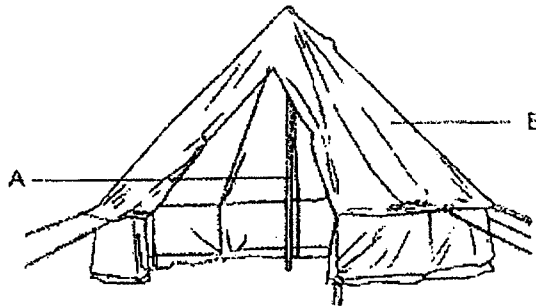

B is used to protect campers from the rain and can be stretched to form the shape of the tent. A is the centre pole that helps to support the weight of B.

Based on the information above, which of the materials, P, Q, R or S, are most suitable for making parts A and B of the tent?

	A	B
(1)	P	Q
(2)	Q	R
(3)	S	P
(4)	R	S

15. Study the diagram of the water cycle shown below.

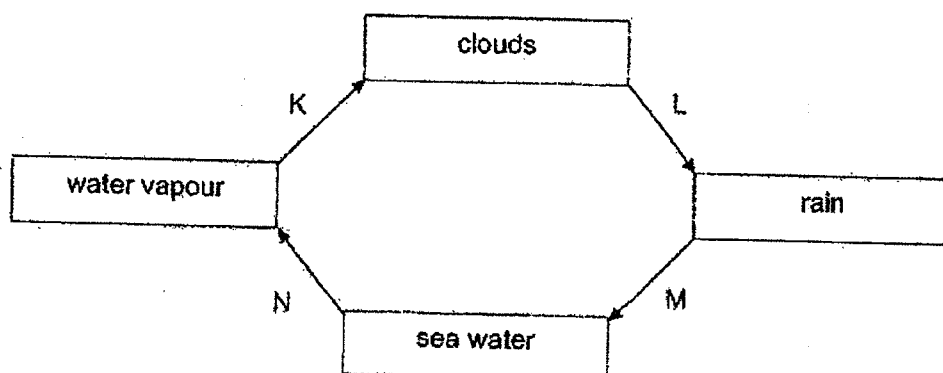

Which one of the following describes processes K, L, M or N correctly?

	Process	Description
(1)	K	heat gained
(2)	L	heat gained
(3)	M	heat loss
(4)	N	heat gained

16. 50 ml of water in a small dish is heated over some time.



The graphs below show the temperature and the volume of water from the start of the experiment.

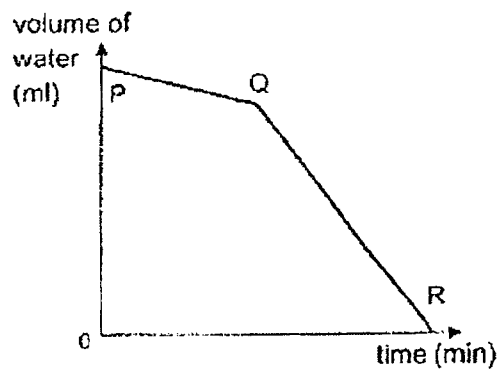
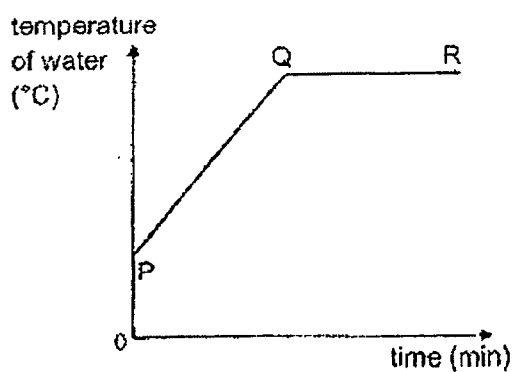

Based on the graphs, which of the following statements are true?

- A The water starts to boil at P.
- B The water starts to boil at Q.
- C The volume of water decreases at PR due to boiling only.
- D The volume of water decreases at PQ due to evaporation.

- (1) A and C only
- (2) A and D only
- (3) B and C only
- (4) B and D only

17. Four students listed ways to conserve water.

Student	Ways to conserve water
T	Wash the car using a water hose.
U	Turn off the tap when brushing our teeth.
W	Fix tap that is leaking as soon as possible.
V	Wash forks and spoons under running water.

Which students suggested ways that help in reducing the usage of water?

- (1) T and W only
 - (2) T and V only
 - (3) U and W only
 - (4) U and V only
18. Liling had three planks made of different materials X, Y and Z. They were of the same length and size. She placed some bricks of 10 kg each on the planks. The diagram below shows her result.

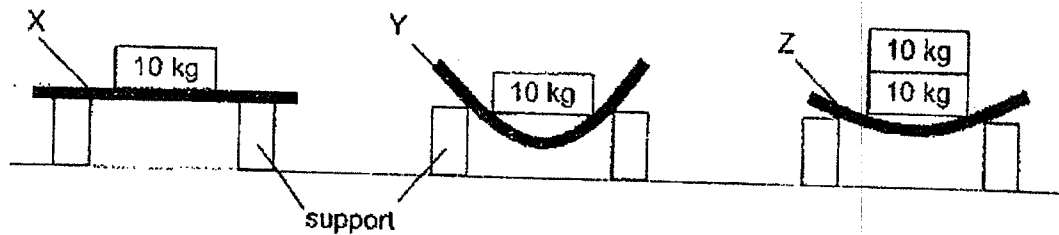

Liling wrote the following statements about the planks.

- A Plank Y is more flexible than plank X.
- B Plank Z is not as flexible as plank Y.
- C Planks X and Z have the same strength.

Based on the results, which of the following statement(s) is/are correct?

- (1) A only
- (2) A and B only
- (3) B and C only
- (4) A, B and C

19. Kasim wanted to find out how different conditions in the environment would affect the rate of evaporation of water. He placed three similar beakers containing 500 ml of water in different environment as shown in the diagram below.

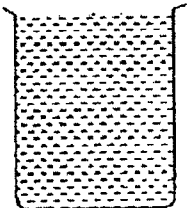
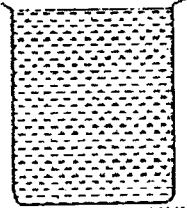
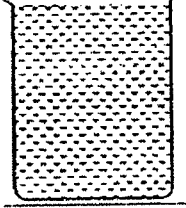
Beaker A	Beaker B	Beaker C
		
Air-conditioned room Temperature: 22°C Wind: Not present	Open field Temperature 32°C Wind: Present	Open field Temperature: 32°C Wind: Not present

Which of the following shows the correct order of beakers?

	Highest amount of water left in the beaker	→	Lowest amount of water left in the beaker
(1)	A		C
(2)	A		B
(3)	B		A
(4)	C		B

20. The table below shows the freezing and boiling points of three substances, E, F and G.

Substance	Freezing point (°C)	Boiling point (°C)
E	19	102
F	-5	18
G	71	134

Which one of the following statements is correct about the substances if they are placed in a room at 26°C?

- (1) Substance E will be in the solid state.
- (2) Substance G will be in the solid state.
- (3) Substances E and F will be in the liquid state.
- (4) Substances E and G will be in the gaseous state.

21. The set up below shows light shining on three wooden objects, X, Y and Z, hanging from a ceiling. They are placed at different distances from the torch.

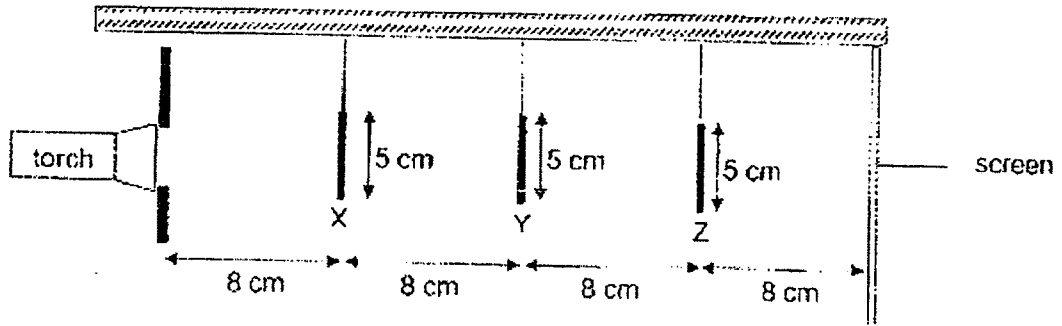

The diagram below shows the shadow of the objects formed on the screen.

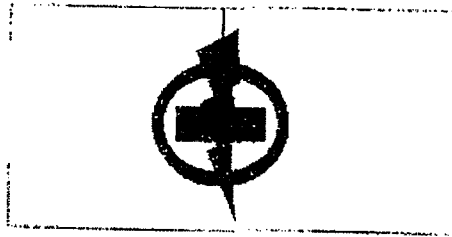

What are objects X, Y and Z?

	X	Y	Z
(1)			
(2)			
(3)			
(4)			

22. The diagram below shows a pump connected to a container which is placed on an electronic balance. The capacity of the container is 3000 cm^3 . It also contains 500 cm^3 of water.

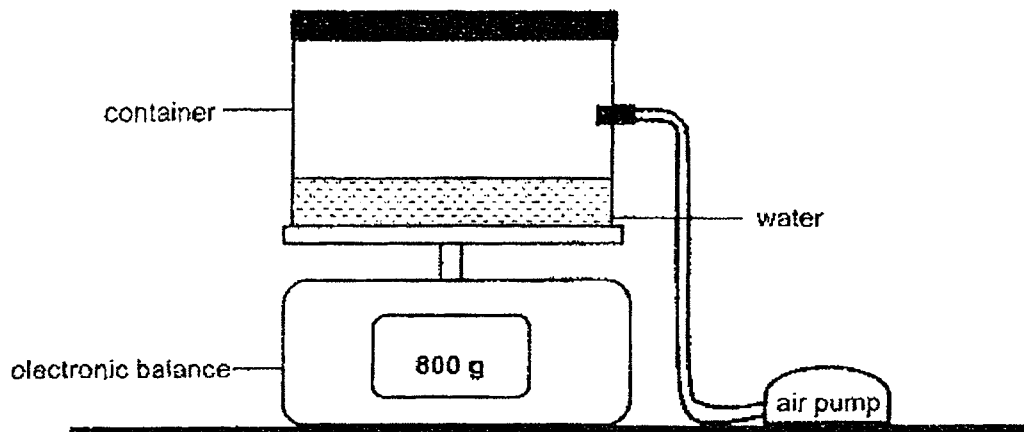

An additional 1000 cm^3 of air was pumped into the container.

Which of the following states the volume of air in the container and the reading on the electronic balance?

	Volume of air in the container (cm^3)	Reading on the electronic balance (g)
(1)	4000	800
(2)	2500	More than 800
(3)	1000	800
(4)	4500	More than 800

23. Susan set up three magnets PQ, RS, TU and an iron bar AB as shown in the arrangement below.

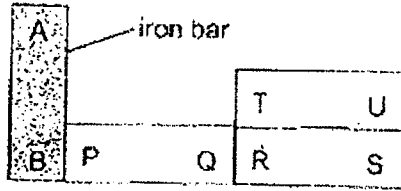

She then re-arranged the three magnets and the iron bar. Which one of the following is another possible arrangement?

(1)

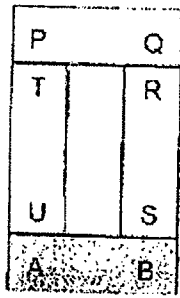

(2)

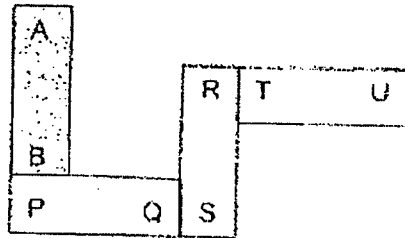

(3)

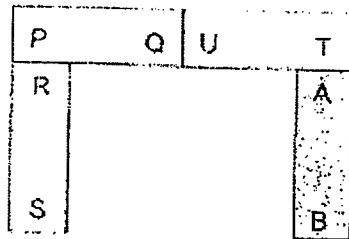

(4)

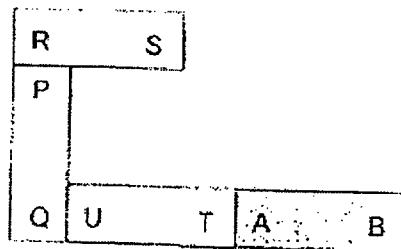

24. A circuit diagram is shown below. There are four blocks, A, B, C and D. Only one of the four blocks is an insulator of electricity. When the switch is closed, only two bulbs light up.

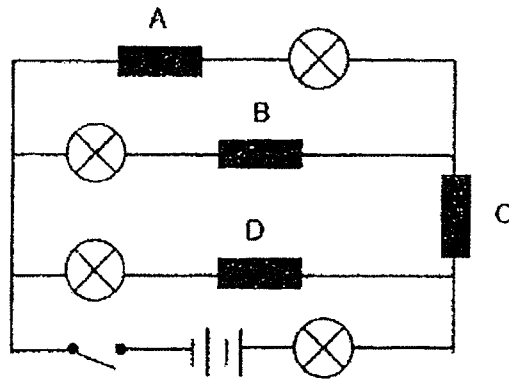

Which one of the blocks is the insulator of electricity?

- (1) A
 - (2) B
 - (3) C
 - (4) D
25. Kenneth sets up an electric circuit using identical bulbs and batteries. In his circuit below, bulb F is unlit while bulb G is lit with a brightness of 2 units.

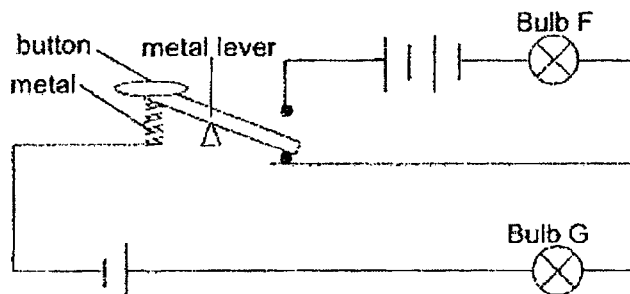

When the button is pressed and held down, what would happen to bulbs F and G?

	Bulb F	Bulb G
(1)	dimmer than 2 units	unlit
(2)	brighter than 2 units	unlit
(3)	dimmer than 2 units	brighter than 2 units
(4)	brighter than 2 units	brighter than 2 units

26. Jia Jun created a game using an electric circuit. The wires were hidden under the card so that only the bulb holders L, M and N could be seen.

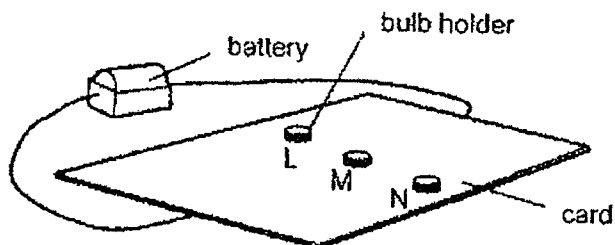

Jia Jun wanted to find out how bulb holders L, M and N were connected using two light bulbs. He recorded his results in the table below.

Bulbs placed at	Observation
M and N	bulbs did not light up
L and N	bulbs lit up
L and M	bulbs lit up

Which one of the following shows the correct circuit used in the game?

(1)

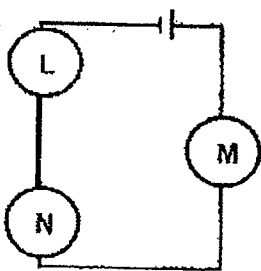

(2)

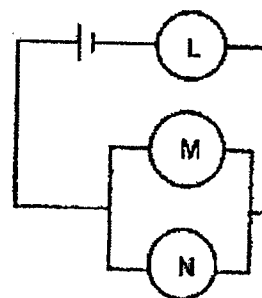

(3)

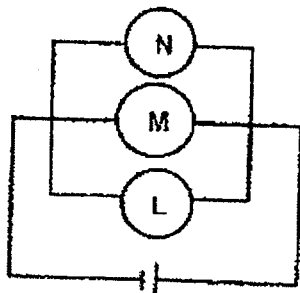

(4)

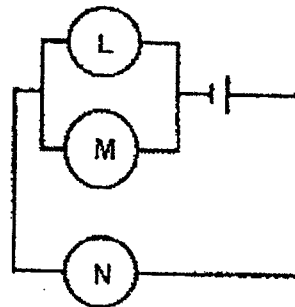

27. Mel set up the following experiment in a dark room. Four sheets of materials, A, B, C and D are arranged in one row at different positions as shown in the diagram below. A circular hole is cut in the middle of the sheet at position P.

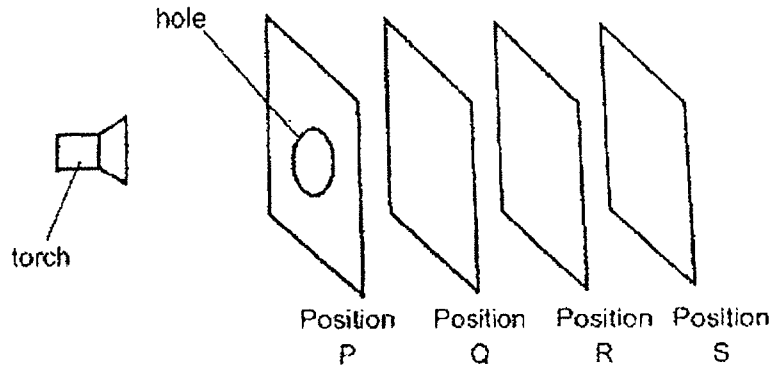

The table below shows the properties of Materials A, B, C and D.

Property of Materials	Materials
Allows light to pass through	A and B
Does not allow light to pass through	C and D

The sheet at Position R is as shown below.

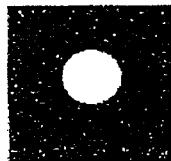

How did Mel arrange the sheets of Materials A, B, C and D to obtain the image at Position R?

	Position P	Position Q	Position R	Position S
(1)	A	B	C	D
(2)	B	C	A	D
(3)	C	A	D	B
(4)	D	C	B	A

28. Kary and Eva constructed the set-ups below that used four identical lamps to heat food. When the lamps were brighter, they gave out more heat. Kary found out that Eva's set-up was hotter than her set-up.

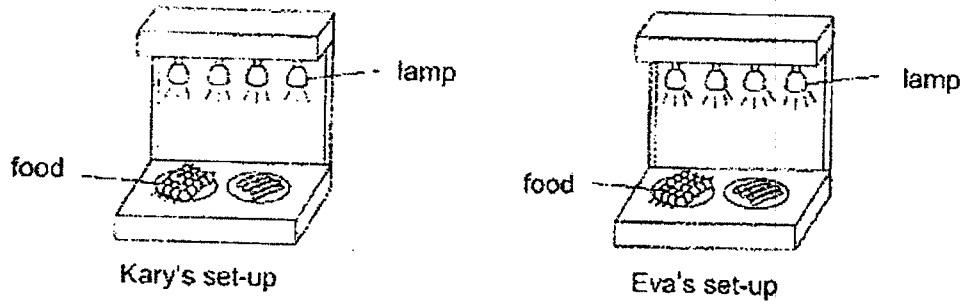

Which one of the following correctly shows the two set-ups?

	Kary's set- up	Eva's set up
(1)		
(2)		
(3)		
(4)		



AI TONG SCHOOL

**2022 END-OF-YEAR EXAMINATION
PRIMARY FIVE SCIENCE**

(BOOKLET B)

27 OCTOBER 2022

Total time for booklets A and B : 1 h 45 min

INSTRUCTIONS

Do not turn over this page until you are told to do so.

Follow all instructions carefully.

Answer all questions.

Write your answers in this booklet.

Name : _____ ()

Class : Primary 5 _____

Parent's Signature : _____

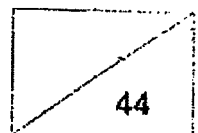

Section B: 44 marks

Read the questions carefully and write down your answers in the spaces provided.

29. The diagram below shows three cells, A, B and C.

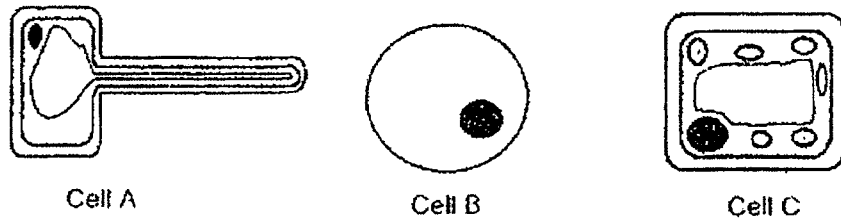

(a) Identify one part of the cell that can be found in all the three cells and state its function.
[1]

The diagram below shows the close-up view of Cell A. Cell A has a long structure and it is found in the roots.

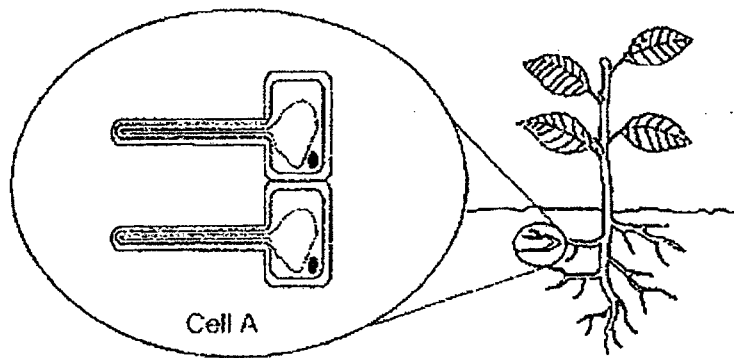

(b) Based on the diagram above, explain how a longer structure on Cell A helps the plant to grow healthier. [2]

(Go on to the next page)

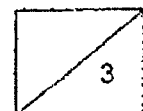

30. Alex conducted an experiment using two similar plants, A and B in his garden. He removed only the food-carrying tubes from plant A at section D as shown below.

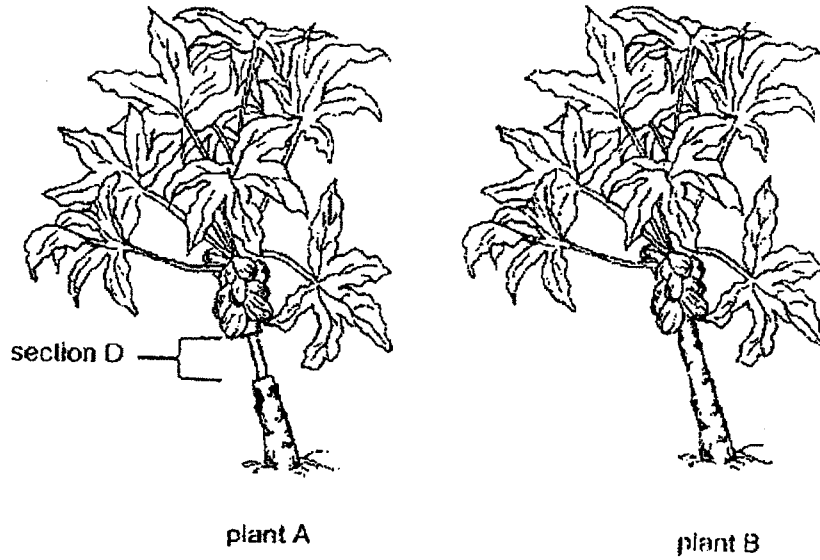

After some time, the two plants produced fruits as shown below.



fruits from plant A



fruits from plant B

- (a) Explain why plant A produced bigger fruits.

[2]

Question 30 continues on the next page.

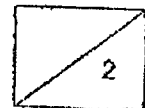

Question 30 continues.

In Alex's garden, there are two other similar plants, K and L. He observed that both plants produce flowers but only one bears fruits. He found that all the flowers on plant K looked different from the flowers on plant L.

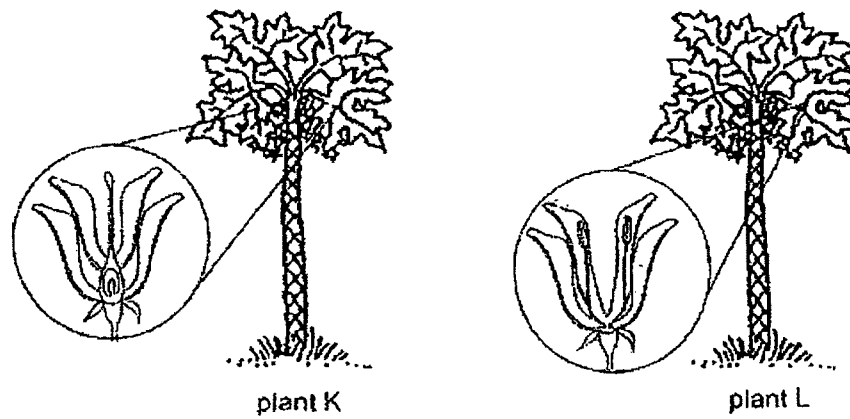

(b) Which plant, K or L, does not bear fruits? Explain your answer. [2]

(Go on to the next page)

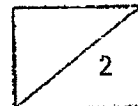

31. Zac studied the leaf under the microscope as shown in the diagram below.

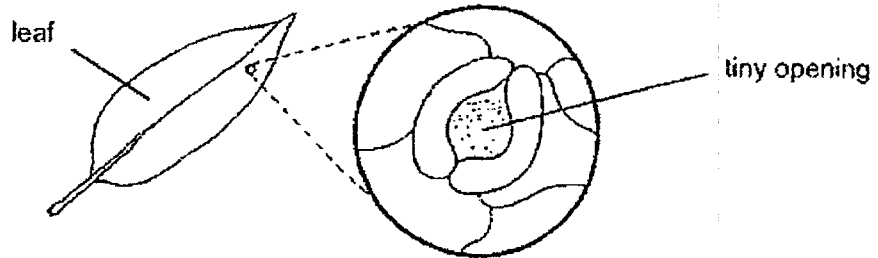

(a) What is the function of these tiny openings on the surfaces of leaves? Include in your answer the gases involved. [1]

Zac set-up an experiment using four similar leaves, P, Q, R and S found on a plant that grows on land. These leaves have tiny openings on both their upper and lower surfaces. He coated some surfaces of the leaves with oil as shown in the table below.

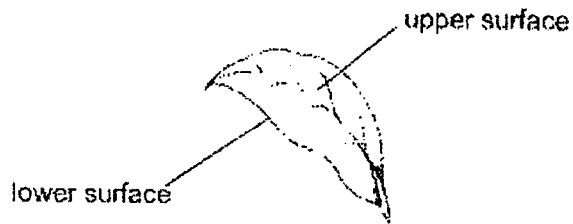

Leaf	Coated with oil	
	Upper surface	Lower surface
P	no	no
Q	yes	no
R	no	yes
S	yes	yes

Question 31 continues on the next page.

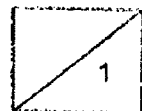

Question 31 continues.

The plant was placed under bright sunlight. He weighed the four leaves after some time. His results are shown in the graph below.

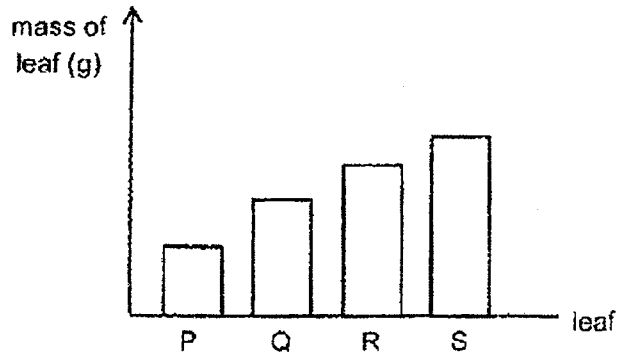

- (b) Arrange the leaves, P, Q, R and S, in order of mass, starting from the leaf that lost the least amount of water through the tiny openings. [1]

- (c) Based on Zac's experiment, are there more tiny openings on the upper or lower surface of the leaf? Explain why. [1]

- (d) Besides using the four leaves from the same plant, what is another characteristic of the leaves that should be kept the same for Zac's experiment to be fair? [1]

(Go on to the next page)

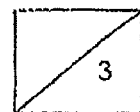

32. There are many air sacs found in our lungs for gaseous exchange to take place. The diagram below shows how each air sac is surrounded by many blood vessels.

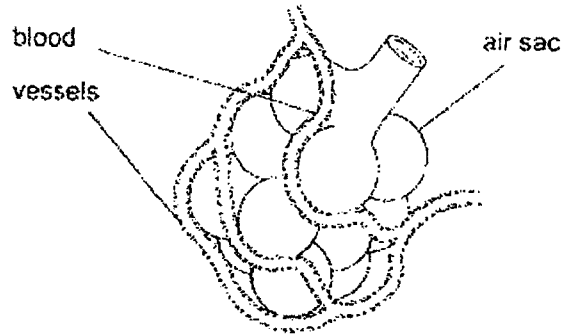

The table below shows the number of breaths taken by two non-smokers and two smokers at rest, as well as the number of air sacs found in a sample of their lungs.

	Number of air sacs	Number of breaths taken in per minute
Non-smoker 1	25	10
Non-smoker 2	18	15
Smoker 1	10	20
Smoker 2	7	25

- (a) Based on the table above, state the relationship between the number of air sacs found in the sample and the number of breaths taken in per minute. [1]

- (b) Explain why the breathing rate of both smokers is higher compared to the breathing rate of the non-smokers. [2]

(Go on to the next page)

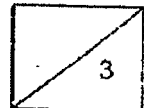

33. The graphs below show the amount of blood transported to the muscles and small intestine and the heart rate of a person during resting and exercise.

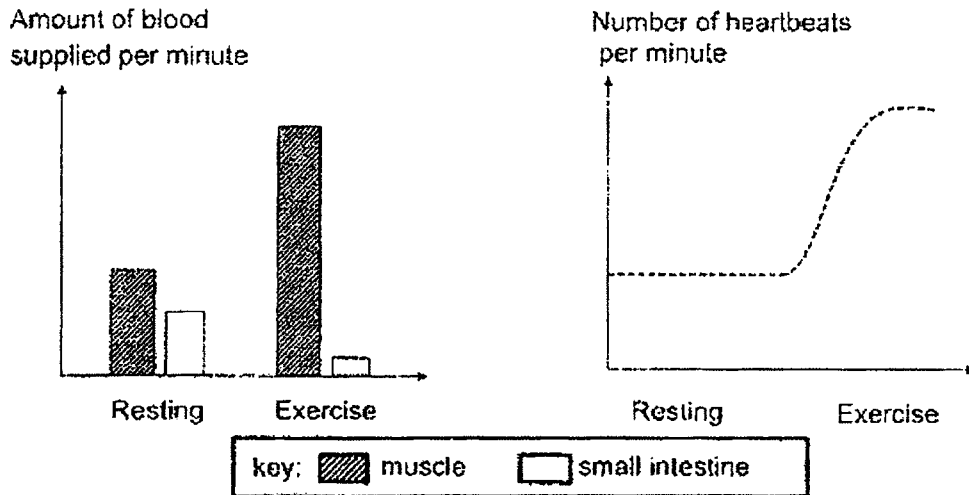

- (a) Based on the graph, explain how the changes in the heart rate during exercise affects the amount of blood transported to the muscles. [2]

The diagram below shows a conversation between two students.

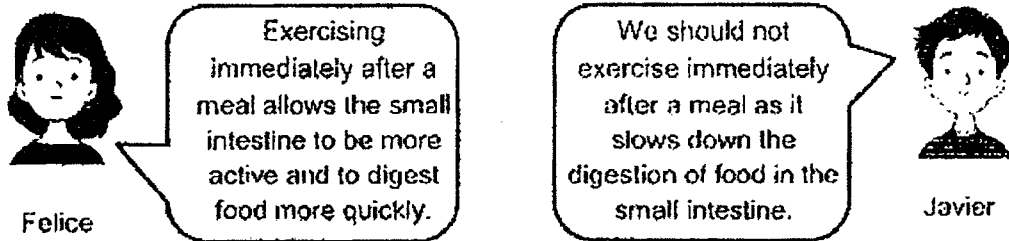

- (b) Whose statement, Felice or Javier, is correct? Explain why. [1]

(Go on to the next page)

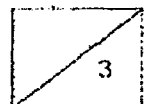

34. Mark wanted to find out how the number of plastic bags used to wrap ice cubes would affect the time taken for ice cubes to change completely into water. He prepared three set-ups, A, B and C, as shown below, with ice cubes of the same size.

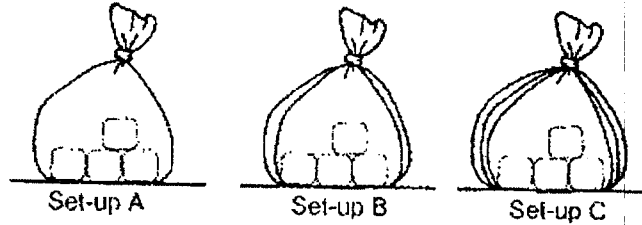

The time taken for all the ice cubes to change into water completely is shown in the table below.

Set-up	Time taken for the ice cubes to change into water completely (minutes)
A	30
B	62
C	54

- (a) Name the process that caused the ice cubes to change into water. [1]
- _____
- (b) Explain how using ice cubes of the same size ensures a fair test. [1]
- _____
- _____
- (c) Do you agree with the results shown in the table above? Explain your answer. [2]
- _____
- _____
- _____

(Go on to the next page)



35. Noah and Javer wanted to find out the amount of force needed to pull different bar magnets apart from a horseshoe magnet. They set up an experiment as shown below. A forcemeter is used to measure the amount of force needed to pull the magnets apart.

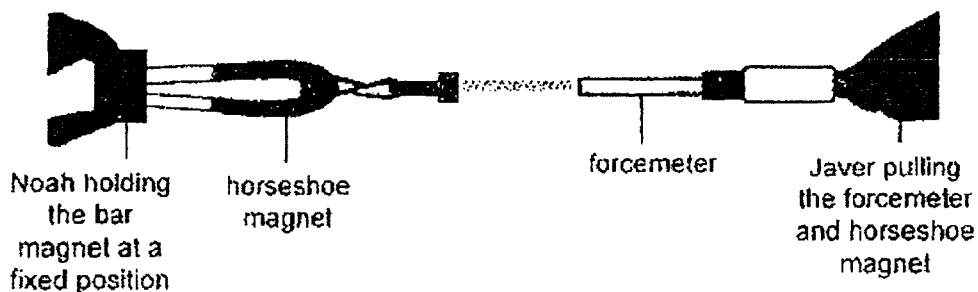

Noah and Javer tested four bar magnets, P, Q, R and S, and recorded their data in the table below.

Bar magnet	P	Q	R	S
Amount of force needed to pull the magnets apart (units)	4	3	9	7

- (a) Based on their results, state and explain which bar magnet, P, Q, R or S has the weakest magnetic strength. [1]

- (b) Using only a steel paper clip and a ruler, describe another way the strength of the bar magnets can be measured. [2]

(Go on to the next page)

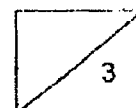

36. Craig placed three plastic boards of different sizes in identical containers, Q, R and S, filled with 500ml of water as shown below. The containers were then placed under the sun for three hours.

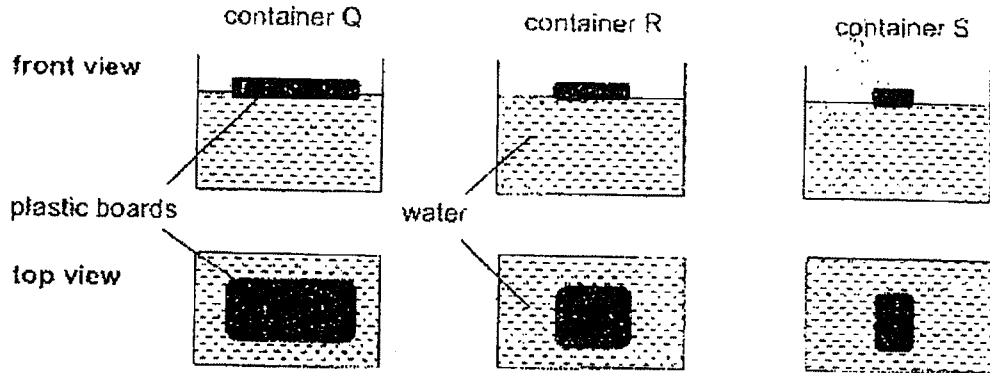

At the end of three hours, Craig recorded the volume of water left in the table below.

Container	Surface area of plastic board (cm ²)	Volume of water left (ml)
Q	80	385
R	40	?
S	20	315

- (a) Based on the results above, predict the amount of water left in container R. [1]

- (b) Suggest how Craig can improve on the reliability of his results. [1]

Question 36 continues on the next page.

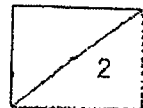

Question 36 continues.

In some countries that experience prolonged periods of hot weather, the reservoirs dry up quickly, resulting in water shortage.

To solve this problem, many floating plastic 'shade' balls are released into the reservoirs as shown in the diagram below.

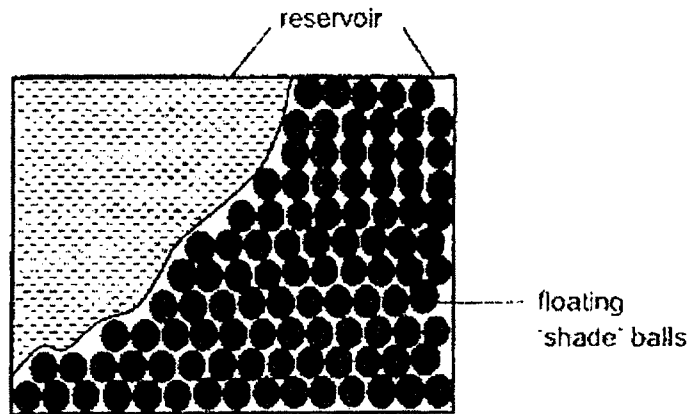

- (c) Explain how the plastic balls help to solve the problem on water shortage. [2]

(Go on to the next page)

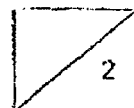

37. An experiment was carried out to study the effect of the amount of carbon dioxide in water and the number of bubbles formed. Two similar set-ups, K and L, were prepared as shown in the diagram below.

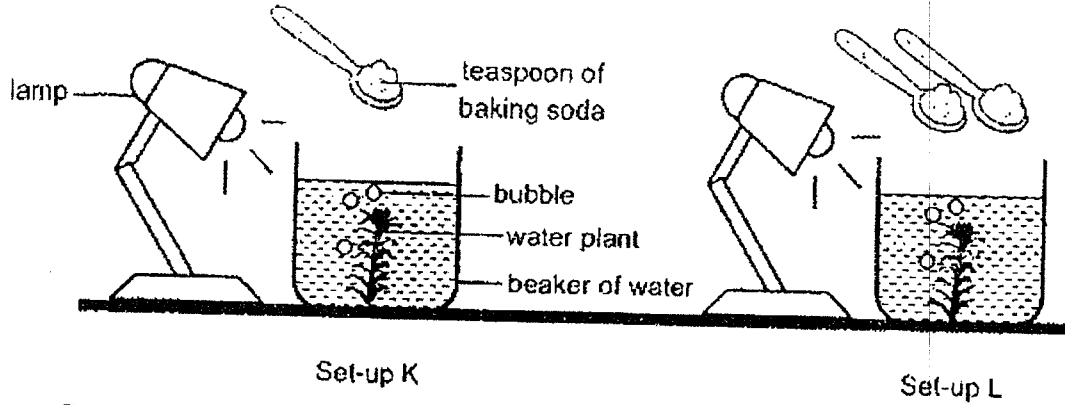

Baking soda was added to increase the amount of carbon dioxide in the water. Bubbles were observed appearing on the plant. The results were recorded in the graph below.

(a) State what the bubbles are and explain how they are formed. [1]

(b) On the graph, indicate in each box which line in the graph represents Set-up K and Set-up L. [1]

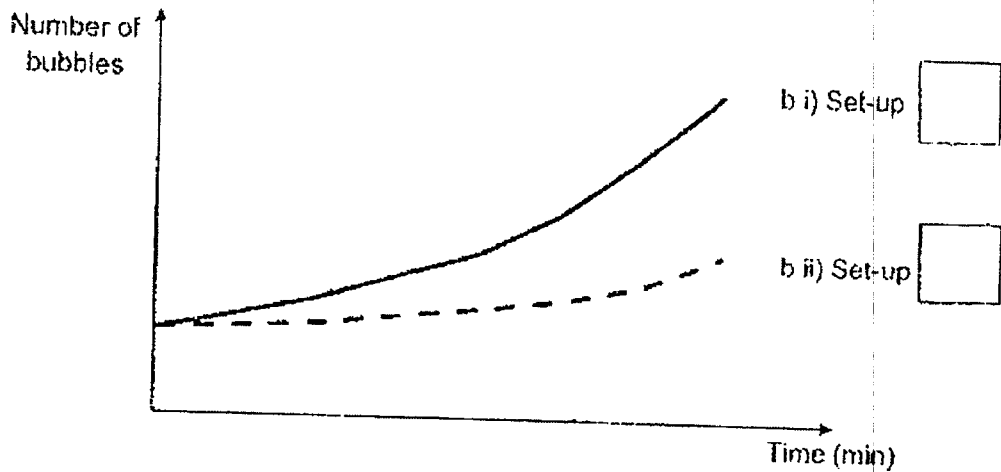

(Go on to the next page)

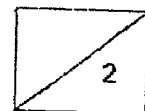

38. On a sunny day, Li Wei conducted an experiment using the set-ups as shown below. After several hours, he observed that clean water was collected at the base of each cone.

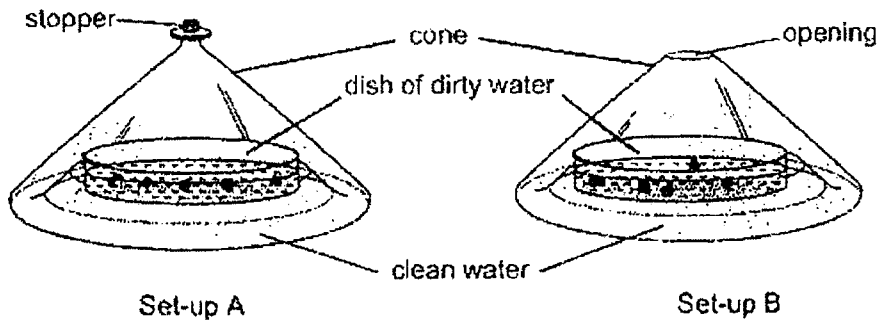

(a) Explain how clean water is collected at the base of the cone in Set-up A. [2]

(b) What would you observe about the amount of water collected in Set-up A and Set-up B? Explain your answer. [2]

(c) Without making changes to the dish of dirty water, suggest how Li Wei can collect more clean water in Set-up A. [1]

(Go on to the next page)

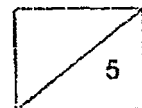

39. A beaker which contains substance P is left on the table for two hours. After two hours, the shape of substance P in the beaker changes as shown below.

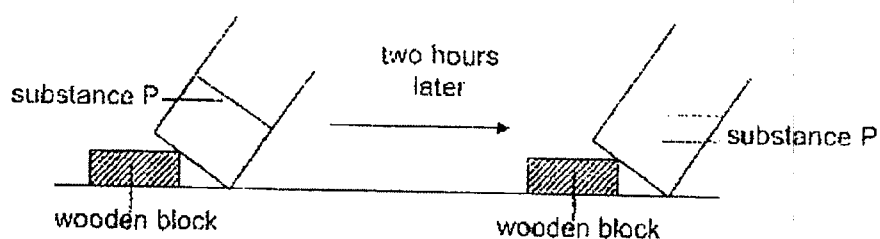

- (a) Which state of matter is substance P at the start of the experiment? Explain why using properties of matter. [1]

A funnel was used to fill a bottle with substance P as shown below.

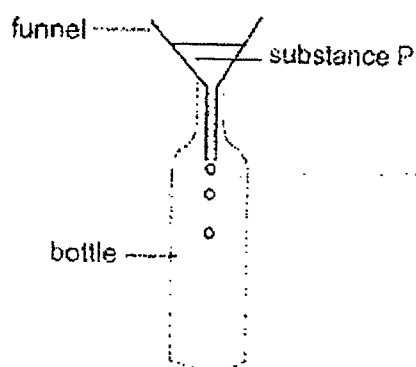

Mary observed that substance P trickled slowly into the bottle at the start. After the funnel was lifted slightly above the mouth of the bottle, substance P entered the bottle at a faster rate.

- (b) Explain Mary's observation. [2]

(Go on to the next page)

40. Wallace wants to set up an electric circuit.

- (a) Complete the circuit diagram below with wires which will enable Wallace to connect the bulbs in maximum brightness and turn on one of the bulbs without affecting the other bulb. [2]

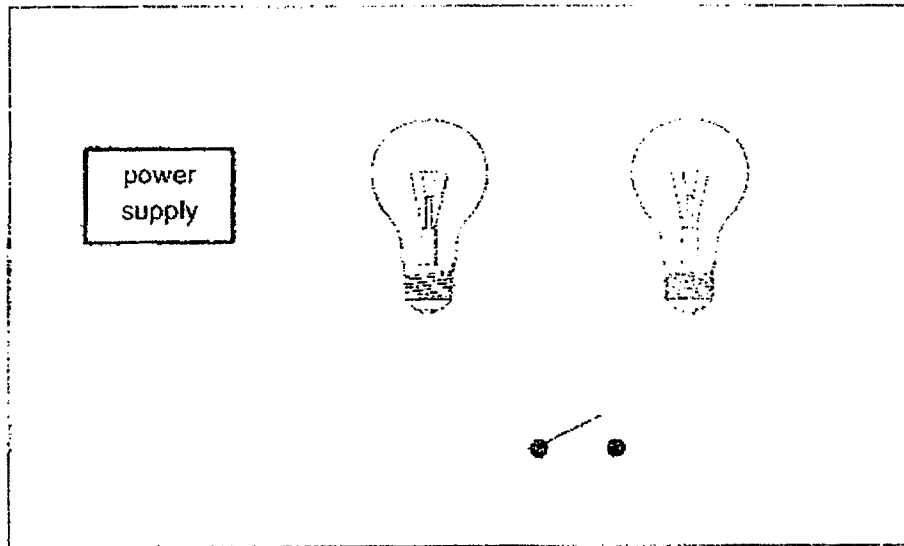

- (b) What is an advantage of the circuit arrangement that you have drawn? [1]

(Go on to the next page)

41. Kai Ming had an aluminium rod, a steel rod and a wooden rod. He connected the three rods at the positions A, B and C as shown in the circuit diagram below.

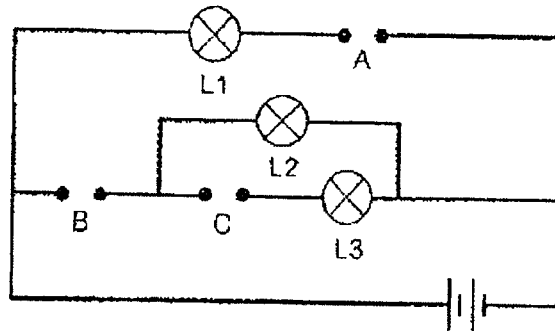

- (a) He observed that only bulbs L1 and L2 were lit. Complete the table below to indicate the position, A, B or C, where the rods are placed in the circuit. [1]

Position			
Material	aluminium	wood	steel

In another experiment, Kai Ming was given a battery, a bulb and a magnet. He chose one of the three objects to place at position C while leaving positions A and B open. Bulbs L2 and L3 were lit.

- (b) Based on his observation, which one of the objects, battery, bulb or magnet, did he place at position C? Explain your answer. [1]

Kai Ming removed some electrical components from the circuit and formed a new circuit as shown below.

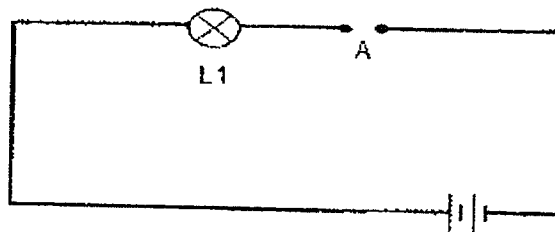

Question 41 continues on the next page.

Question 41 continues.

- (c) Kai Ming placed two more batteries at A. He observed that bulb L1 lit up brightly only for a short while and then did not light up. Explain why. [1]

End of paper

B-17

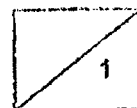

SCHOOL : AI TONG PRIMARY SCHOOL
LEVEL : PRIMARY 5
SUBJECT : SCIENCE
TERM : 2022 SA2

SECTION A

Q 1	Q2	Q3	Q4	Q5	Q6	Q7	Q8	Q9	Q10
3	1	1	4	2	2	4	2	4	1
Q 11	Q12	Q13	Q14	Q15	Q16	Q17	Q18	Q19	Q20
3	4	4	1	4	4	3	2	2	2
Q21	Q22	Q23	Q24	Q25	Q26	Q27	Q28		
3	2	1	3	4	2	3	3		

Al Tong School
Primary 5 End of Year Exam 2022
Science Booklet B Correction

Name: _____ ()

Date: _____

Class: 5 _____

No.	Suggested Answers (full marks or partial marks)	Things to note.
29a	<p>Cell membrane - Controls <u>movement</u> of substances in and out of the cell.</p> <p>Nucleus - Contains <u>genetic</u> information OR controls all activities in the cell.</p> <p>Cytoplasm - Place where cell <u>activities</u> take place OR Allows substances to move around within the cell.</p>	
29b	<p>Point 1: The longer structure on cell A increases the exposed <u>surface</u> area of the root in contact with the soil.</p> <p>Point 2: Therefore, the root can <u>absorb</u> more water and mineral salts.</p>	<p>Nutrients are not the same as mineral salts.</p> <p>Nutrients include all substances that provide nourishment e.g., carbohydrates, proteins, fats, minerals etc.</p> <p>Roots absorb mineral salts from the soil.</p>
30a	<p>Point 1: Food made by the leaves could not be <u>transferred</u> to the parts of the plant below Section D.</p> <p>Point 2: Hence, the food <u>was stored</u> in the fruits above section D.</p>	<p>Use the labelling provided in the diagram (e.g., below/above section D) to explain your answers clearly.</p> <p>Not all the food is transported to the fruits.</p>

30b	<p>Choice: Plant L</p> <p>Data: The <u>female</u> reproductive parts of the flower are absent.</p> <p>Explain: Hence, no <u>pollination</u> and <u>fertilisation</u> could take place.</p>	Name the process instead of defining them if not required by the question.
31a	<p>The tiny opening allows the plant to take in gases and give out gases like <u>oxygen</u> and <u>carbon dioxide</u>. Water vapour also escapes through the tiny openings.</p>	
31b	S, R, Q, P.	
31c	<p>Choice: There are more <u>stomata</u> on the lower surface of the leaf</p> <p>Data: The <u>mass</u> of leaf Q is lesser than the mass of leaf R.</p> <p>Explain: Q lost <u>more</u> water through the tiny openings on the lower surface than R.</p>	Structure your answers using CDE.
31d	<p>The mass of the leaf at the <u>start of experiment</u></p> <p>OR</p> <p>Surface area or size of the leaves.</p>	<p>Answer must be practical.</p> <p>e.g., Number of tiny openings on the upper and lower surface of the leaf is not accepted as it is not possible to count.</p>
32a	<p>As the number of air sacs <u>increases</u>, the number of breaths taken in per minute <u>decreases</u>.</p>	<p>Use the sentence structure, As the (cause) <u>increases/decreases</u>, the (effect) <u>increases/decreases/remains the same</u>.</p>

32b	<p>Data: A smoker has a lesser number of air sacs.</p> <p>Explain: Hence, the breathing rate increases to increase the amount of <u>oxygen</u> taken in.</p>	
33a	<p>During exercise our body needs more energy. The heart rate increases during exercise to pump more <u>blood</u> faster to transport more <u>oxygen</u> and <u>digested food</u> to our muscles to release more energy for the exercise.</p> <p>At the same time more carbon dioxide and other waste materials can be transported away from the muscles quickly.</p>	
33b	<p>Javier. There is lesser blood supplied to the small intestine during exercise.</p>	
34a	<p>Melting.</p>	
34b	<p>The difference in the results of the experiment is solely due to the number of plastic bags and not other variables like the size of ice cubes.</p>	<p>Do not confuse fair test with reliability (Q36a) of results.</p>
34c	<p>Choice: No.</p> <p>Data: The time taken for the ice in set-up C to melt should be <u>longer</u> than that in set-up B.</p> <p>Explain: C has more plastic bags which is a <u>poor</u> conductor of heat. Therefore, heat transfer from the surroundings to the ice is <u>slower</u>.</p> <p>OR</p> <p>There is more air trapped in between the plastic bags. Air is a poor conductor of heat. Therefore, heat transfer from the surroundings to the ice is slower.</p>	<p>Ensure heat transfer is described clearly.</p>

35a	Magnet Q. The amount of force needed to pull the magnets apart is the <u>least</u> .	Use the measure variable given in the table to ensure your wording are clear.
35b	Place the paper clip on a table at a fixed position. Use the magnet to attract it at a distance. Measure the <u>distance</u> between the magnet and paper clip when it attracts.	State the measured variable clearly.
36a	Any value between 315 to 385 ml.	Remember to write your units.
36b	To obtain reliable results, he should <u>repeat</u> the experiment at least three times, check for <u>consistency</u> of his result and calculate the average.	
36c	The floating shade balls decrease the exposed surface area of <u>water</u> in the reservoir. Hence, less water will gain heat from the surrounding air slowing down the rate of evaporation of water	
37a	Oxygen. The water plant carries out photosynthesis.	
37b	b(i) L b(ii) K	
38a	Water in the dish gains heat from the surroundings and <u>evaporates</u> to form water vapour. The warmer water vapour from the dirty water comes into contact with the <u>cooler</u> upper surface of the cone, loses heat and <u>condenses</u> to form water droplets which then drips down and is collected at the base of the cone.	Ensure the source of water vapour is identified. Temperature difference between the water vapour and cooler surface must be stated clearly.

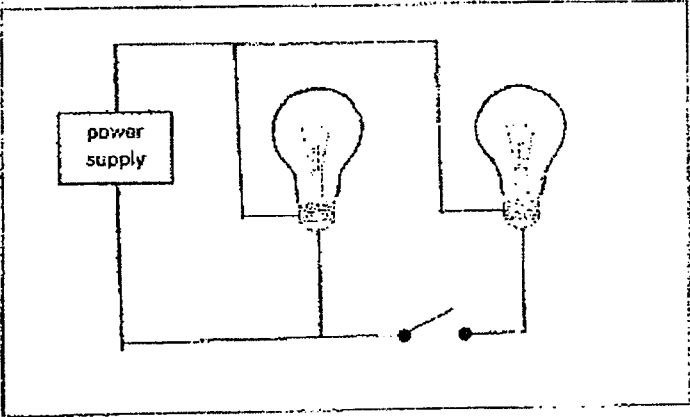
38b	<p>The amount of water in B would be less than A.</p> <p>Some water vapour in the cone in set-up B <u>escaped</u> into the surrounding through the opening at the top of the cone. This results in lesser water vapour condensing to form lesser water in B.</p>	<p>Explain why B collects less water vapour. Need to show comparison.</p>
38c	<p>Add a cold ice pack on the cone.</p>	
39a	<p><u>Solid</u> state. Substance P has a <u>definite</u> shape and does not take the shape of the container when tilted.</p>	
39b	<p>Air in the bottle occupies the <u>space</u>.</p> <p>Therefore, substance P trickled slowly into the bottle.</p> <p>Air will <u>escape</u> when the funnel is lifted, causing P in the funnel to enter the bottle to occupy the space previously occupied by air.</p>	
40a		<ol style="list-style-type: none"> 1. Determine the type of circuit (parallel or series) to draw. Clue: bulbs in maximum brightness'. Therefore, the bulb needs to be connected parallel to each other. 2. Ensure that the metal tip and the metal casing of the bulb are connected to the opposite terminals of the power supply.
40b	<p>When one bulb <u>fuses</u>, the other bulbs can still be lit.</p>	<p>Incomplete answer:</p>

		When one bulb fuses, the other bulbs will not fuse - doesn't show that the circuit the other bulb is connected to remains closed and that the other bulb will continue to light up																
41a	<table border="1"> <tr> <td>position</td> <td>A</td> <td>C</td> <td>B</td> </tr> <tr> <td>material</td> <td>aluminium</td> <td>wood</td> <td>steel</td> </tr> </table> <p style="text-align: center;">OR</p> <table border="1"> <tr> <td>position</td> <td>B</td> <td>C</td> <td>A</td> </tr> <tr> <td>material</td> <td>aluminium</td> <td>wood</td> <td>steel</td> </tr> </table>	position	A	C	B	material	aluminium	wood	steel	position	B	C	A	material	aluminium	wood	steel	
position	A	C	B															
material	aluminium	wood	steel															
position	B	C	A															
material	aluminium	wood	steel															
41b	Battery. At position C, the battery and the two bulbs, L2 and L3, formed a <u>closed</u> circuit, allowing electricity to follow through.																	
41c	Too much electricity flowed through the circuit, causing the light bulb to <u>fuse</u> .																	