



2022 PRIMARY 4 END-OF-YEAR EXAMINATION

Name : _____ ()

Date: 28 October 2022

Class : Primary 4 ()

Time: 8.00 a.m. - 9.30 a.m.

Parent's Signature : _____

Duration: 1 hour 30 minutes

SCIENCE BOOKLET A

INSTRUCTIONS TO CANDIDATES

1. Write your name, class and register number.
2. Do not turn over this page until you are told to do so.
3. Follow all instructions carefully.
4. Answer all questions.
5. Shade your answers on the Optical Answer Sheet (OAS) provided.

Booklet A (22 x 2 marks)

For each question from 1 to 22, four options are given. One of them is the correct answer. Make your choice (1, 2, 3 or 4) and shade your answer on the Optical Answer Sheet.

(44 marks)

1. The diagram below shows the life cycle of an animal.

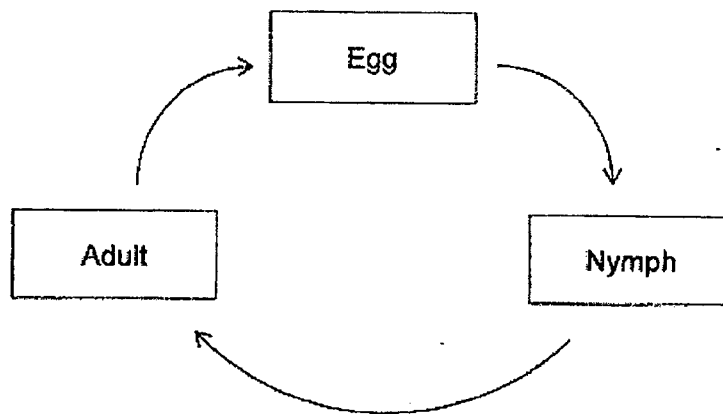

Which animal is likely to have the life cycle as shown above?

- (1) beetle
 - (2) chicken
 - (3) butterfly
 - (4) cockroach
2. In which part of the human digestive system is the digestion of food completed?
- (1) gullet
 - (2) stomach
 - (3) small intestine
 - (4) large intestine

3. A snail hides itself in its shell when touched.

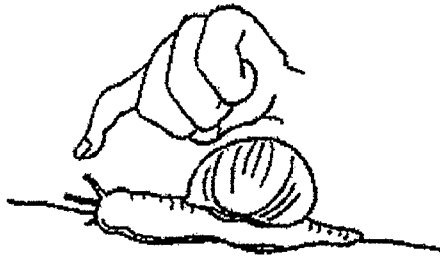

This shows that the snail is a living thing because it can _____.

- (1) grow
 - (2) breathe
 - (3) respond
 - (4) reproduce
4. Which of the following objects can be bent easily without breaking?

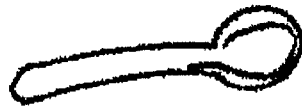

wooden spoon

(1)



ceramic cup

(2)

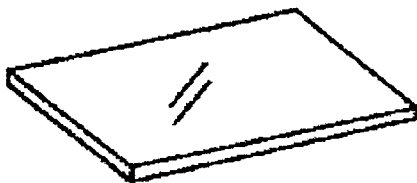

a sheet of glass

(3)



rubber gloves

(4)

5. Thomas places a metal spoon into a cup of hot coffee.

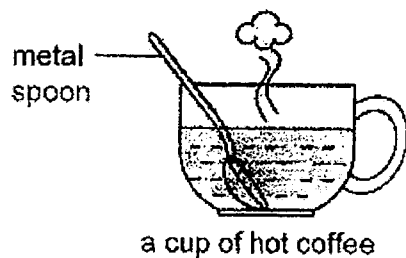

The spoon becomes hotter after a while.

Which of the following explains this?

- (1) The cup loses heat to the hot coffee.
 - (2) The spoon loses heat to the hot coffee.
 - (3) The hot coffee gains heat from the spoon.
 - (4) The spoon gains heat from the hot coffee.
6. In which one of the following will the two magnets push each other away?

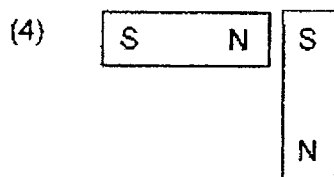
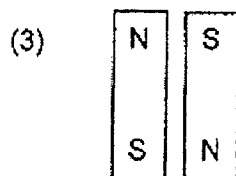
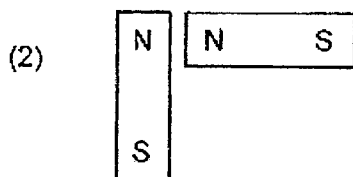
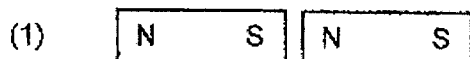

7. Which one of the following is a source of light?

(1)



burning matchstick

(2)



moon

(3)



cat's eyes

(4)



coins

8. Which one of the following substances has a fixed shape?

- (1) oil
- (2) air
- (3) milk
- (4) stone

9. Which one of the following is the function of the roots of a plant?

- (1) makes food
- (2) takes in water
- (3) absorbs sunlight
- (4) holds the plant upright

10. The diagram below shows the stages in the growth of plant X.

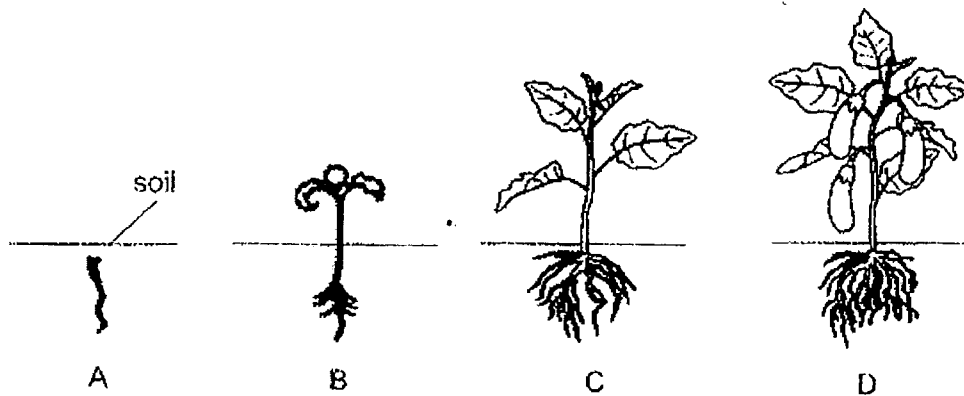

At which stage is plant X an adult plant?

- (1) A
 (2) B
 (3) C
 (4) D
11. A lighted bulb was placed in the middle of a cardboard box as shown below. Four rubber tubes, Q, R, S and T, were placed in the box.

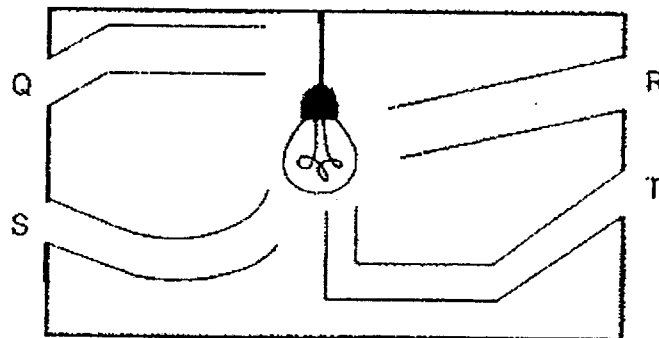

Which of the following tubes could be used to see the bulb?

- (1) Q
 (2) R
 (3) S
 (4) T

12. Ken wanted to find out if plants take in water through their roots. He had plants of the same type in set-ups M and N with the same amount of water.

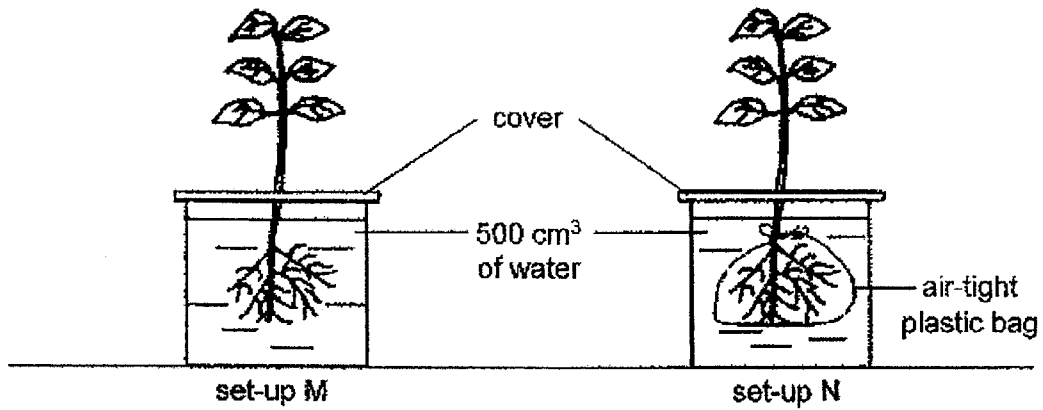

What should Ken measure or observe to find out if roots take in water?

- (1) length of root
- (2) number of roots
- (3) amount of water left
- (4) temperature of water

13. The diagram below shows the changes in the state of matter.

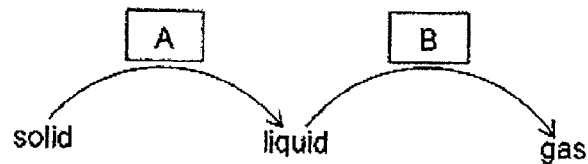

Which of the following correctly shows the heat gain or heat loss of a substance when changing from one state to another?

	A	B
(1)	heat gain	heat gain
(2)	heat gain	heat loss
(3)	heat loss	heat loss
(4)	heat loss	heat gain

14. Study the set-up below. The volume of the air-tight container is 100 cm^3 .

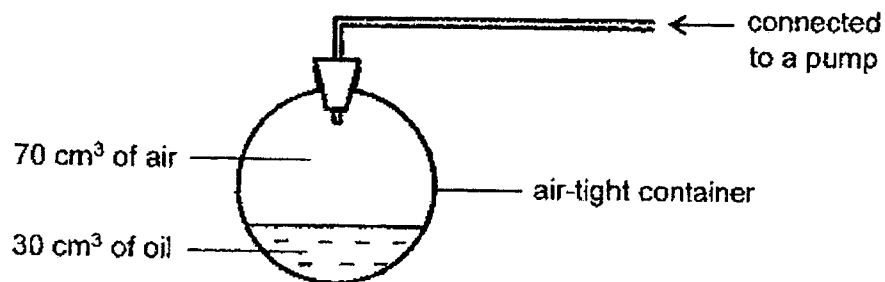

Using the pump, 10 cm^3 of oil and 20 cm^3 of air are added into the above set-up.

What is the final volume of air in the container?

- (1) 40 cm^3
 (2) 60 cm^3
 (3) 70 cm^3
 (4) 90 cm^3

15. Daniel filled two identical syringes, X and Y, with the same volume of stones and air as shown below. He covered each syringe with one finger.

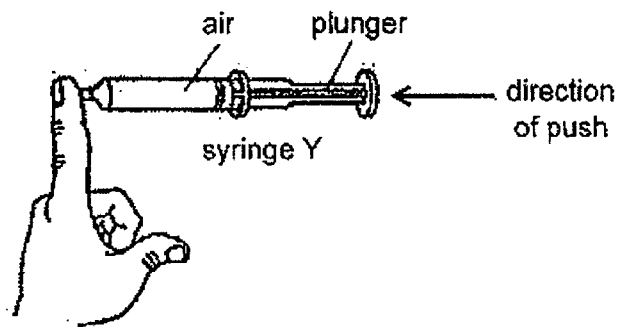
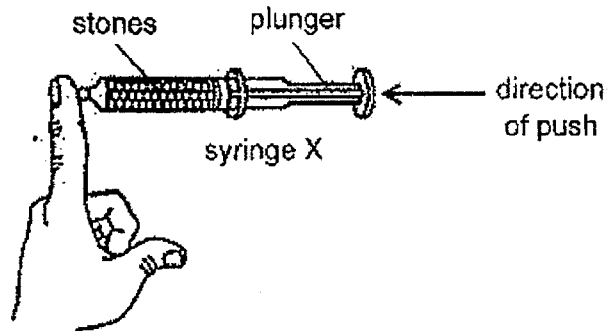

When Daniel pushed the plunger of each syringe, he observed that the plunger of syringe X could not be moved while the plunger of syringe Y moved in a little.

Based on Daniel's observations above, which of the following conclusions could he make?

- (1) Air is a matter.
- (2) Air has no definite volume.
- (3) Stones can be compressed.
- (4) Stones have a definite mass.

16. Jack placed the following two objects of different sizes and materials under two identical lamps.



He placed them in two different positions as shown below.

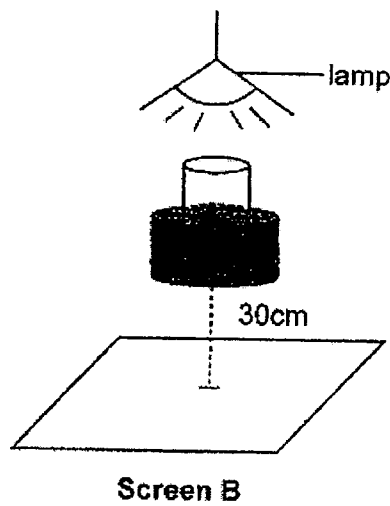
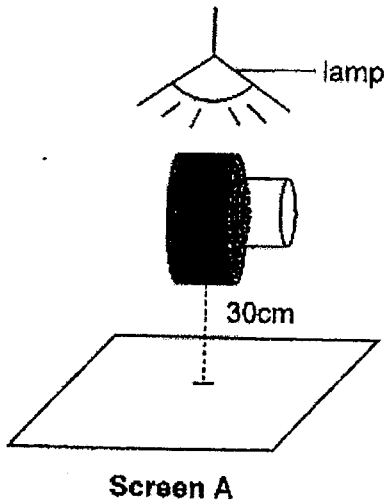

Which of the following shadows would be observed on each screen?

	Screen A	Screen B
(1)		
(2)		
(3)		
(4)		

17. A wooden spoon and a metal spoon of the same size, which were both originally at 30°C , were placed into a cup of cold water at the same time.

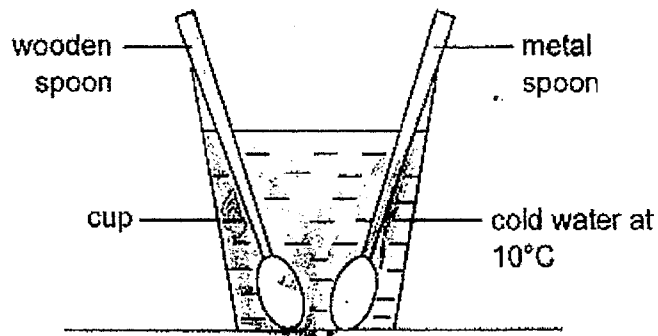

What is most likely the temperature of both spoons after two minutes?

Temperature ($^{\circ}\text{C}$)		
	Wooden spoon	Metal spoon
(1)	25	18
(2)	12	28
(3)	30	30
(4)	10	10

20. Three objects made of different materials and different shapes, are arranged in a straight line at positions X, Y and Z in a dark room as shown below.

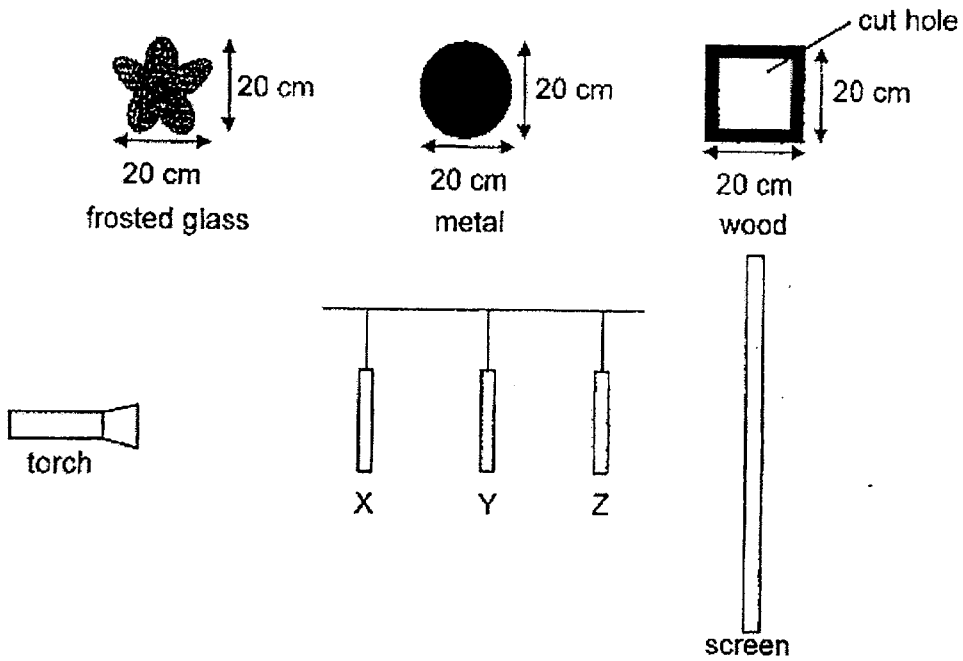

The diagram below shows the shadow formed on the screen when the torch is switched on.



Which one of the following shows the correct objects at positions X, Y and Z?

	X	Y	Z
(1)			
(2)			
(3)			
(4)			

- 21 Four containers, P, Q, R and S, made of different materials, are set up as shown below and placed in a room at room temperature. Each container contains equal volume of water at 100°C .

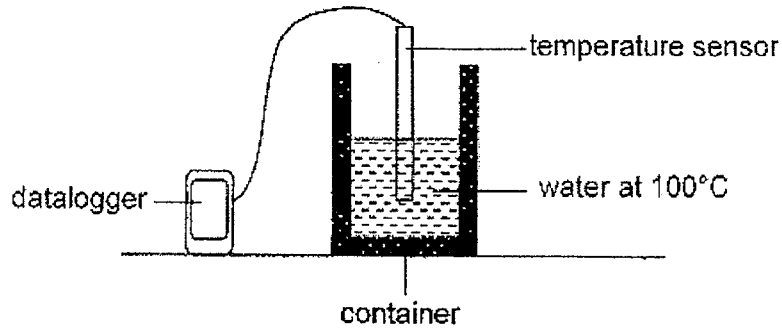

A temperature sensor is placed in the container of water to measure the change in temperature of the water over some time.

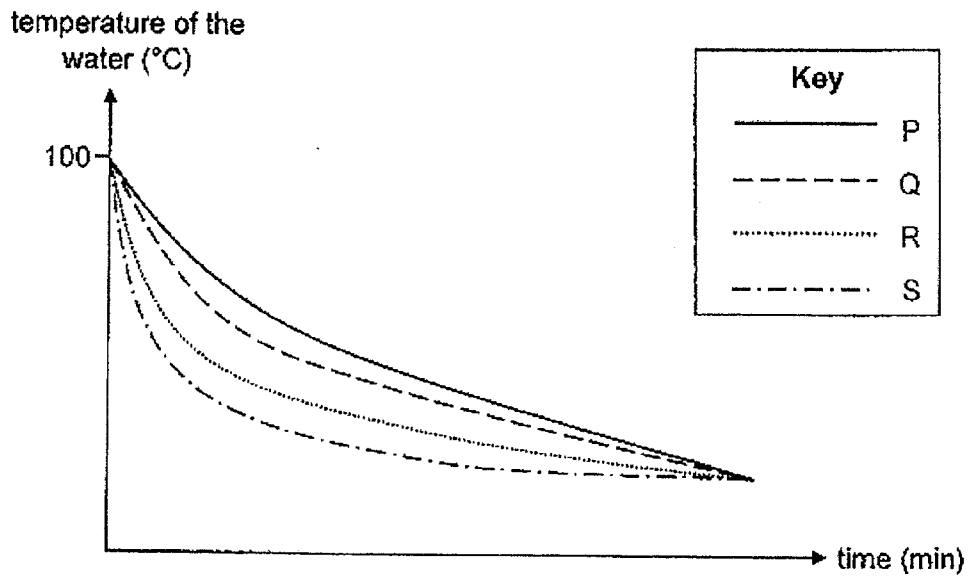

Which container is most suitable to keep ice cubes cold for the longest period of time?

- (1) P
- (2) Q
- (3) R
- (4) S

22. An experiment was set up as shown below.

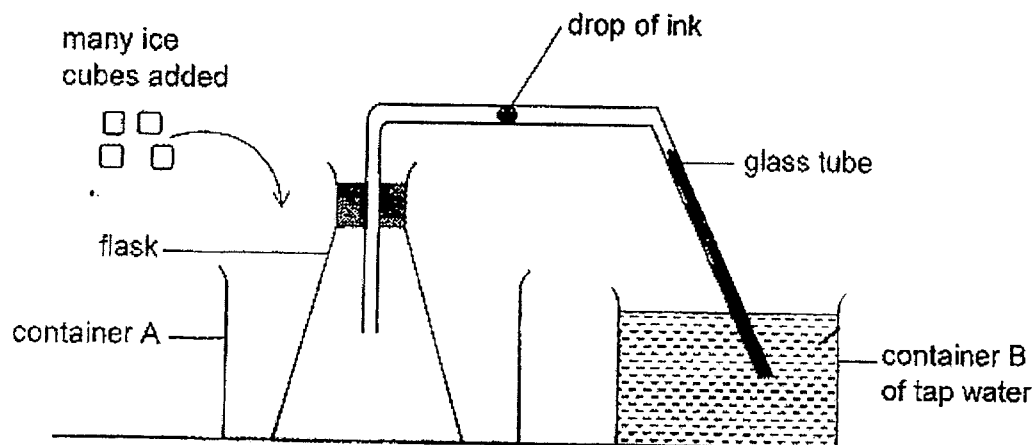

Which of the following is a possible observation after many ice cubes were added to fill container A?

- (1) The water level in container B rises.
- (2) The water level rises in the glass tube.
- (3) The drop of ink moves away from the flask.
- (4) There are bubbles seen leaving the glass tube.

End of Booklet A



2022 PRIMARY 4 END-OF-YEAR EXAMINATION

Name : _____ ()

Date: 28 October 2022

Class : Primary 4 ()

Time: 8.00 a.m. – 9.30 a.m.

Parent's Signature : _____

Duration: 1 hour 30 minutes

SCIENCE

BOOKLET B

INSTRUCTIONS TO CANDIDATES

1. Write your name, class and register number.
2. Do not turn over this page until you are told to do so.
3. Follow all instructions carefully.
4. Answer all questions.
5. Write your answers in the booklet.

Booklet A	44
Booklet B	36
Total	80

Booklet B (36 marks)

For questions 23 to 34, write your answers clearly in this booklet.

The number of marks available is shown in brackets [] at the end of each question or part question.

(36 marks)

23. Classify the following living things under the correct headings in the table below. [2]



fern

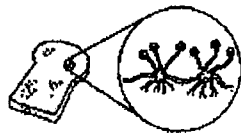

mould



mushroom



tree

Plants	Fungi

Score	2
-------	---

24. The diagram below shows a plant.

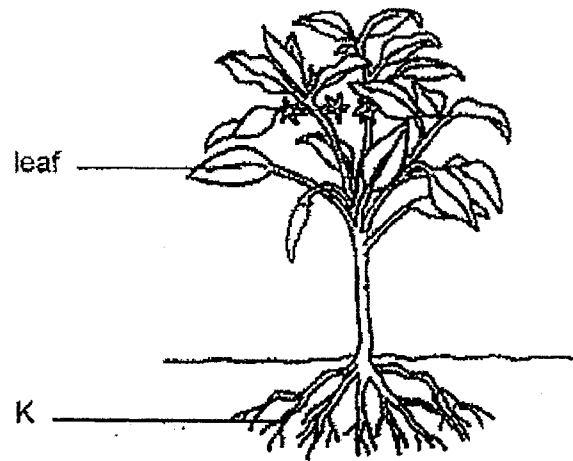

(a) Name part K. [1]

K: _____

(b) The leaf absorbs sunlight to make _____ for the plant. [1]

25. The picture below shows a pan with some oil in it.

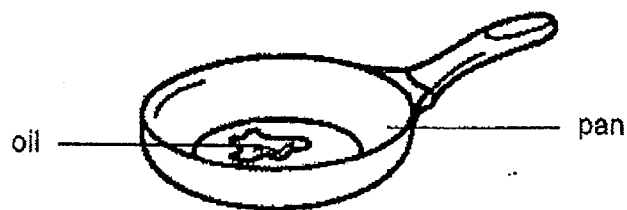

Circle the correct state for the following things.

(a) pan: solid / liquid / gas [1]

(b) oil: solid / liquid / gas [1]

Score	4
-------	---

26. The diagram below shows how Rani sees a ball.

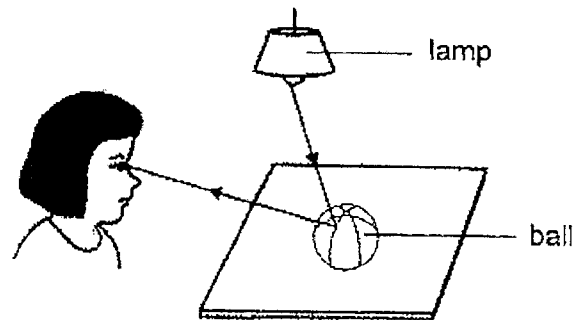

The _____ from the lamp is _____ by the ball and enters Rani's eyes. [2]

27. Sally brought end P of a magnet near end T of an object as shown below. She observed that the object moves away from the magnet.



- (a) Based on her observations, what can Sally conclude about the object? [1]

- (b) What will happen if Sally brings end P of the magnet near end U of the object? [1]

	4
Score	4

28. The diagram below shows the life cycles of a butterfly and a grasshopper.

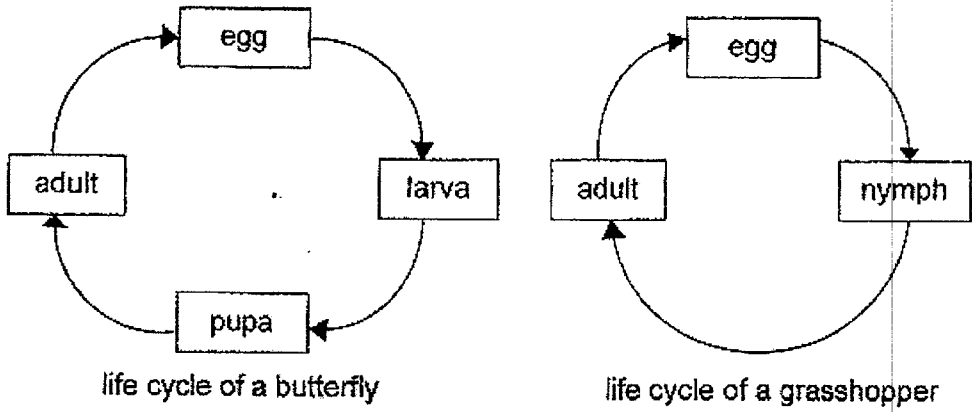

(a) Based on the diagrams above, state two differences between the life cycles of the butterfly and grasshopper. [2]

Difference 1:

Difference 2:

(b) The diagram below shows the life cycle of a plant. Fill in the missing stage in the box below. [1]

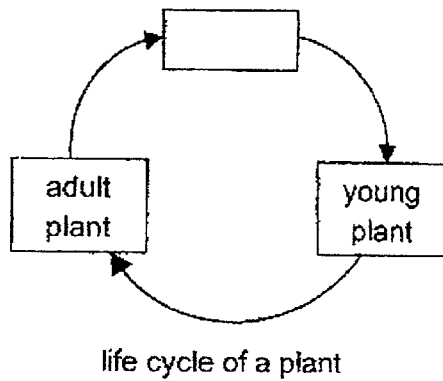

Score	3
-------	---

30. Maria ate a plate of chicken rice. The graph below shows the amount of undigested food leaving each organ of her digestive system, P, Q, R, large intestine and gullet, after a meal. (The organs are not placed in sequence.)

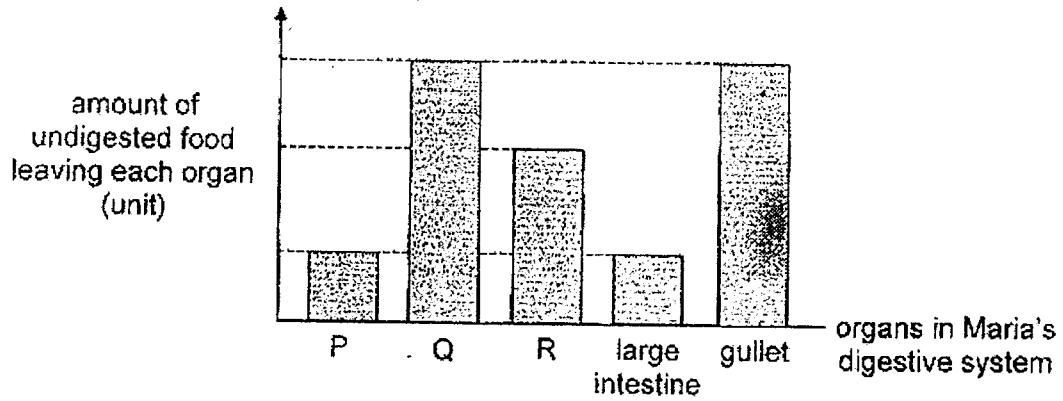

- (a) Identify organs P and Q. [1]

P: _____

Q: _____

- (b) Explain why the amount of undigested food leaving organ P and the large intestine are the same. [1]

Score	2
-------	---

Maria cut up her cooked chicken meat into smaller pieces before eating.



100 g of cooked chicken meat

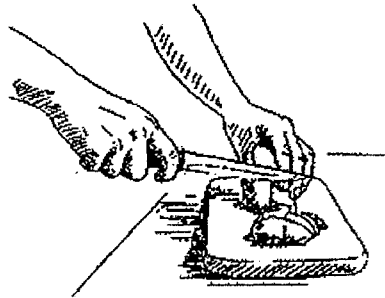

100 g of cooked chicken meat cut into pieces

(c) Explain how cutting up the chicken meat affects the rate of digestion. [2]

Score	2
-------	---

31. Henry inserted a balloon into a plastic bottle which contained some water. He stretched the opening of the balloon over the mouth of the bottle as shown in the diagram below.

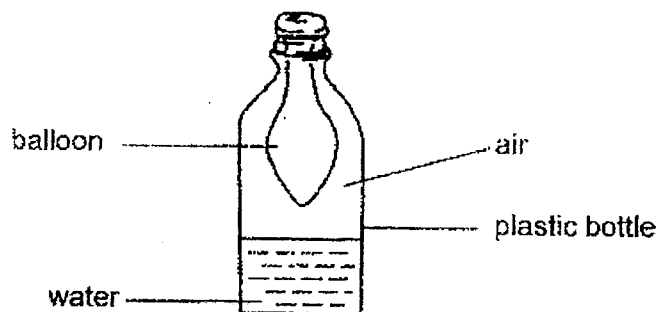

He then tried to blow into the balloon as shown below.

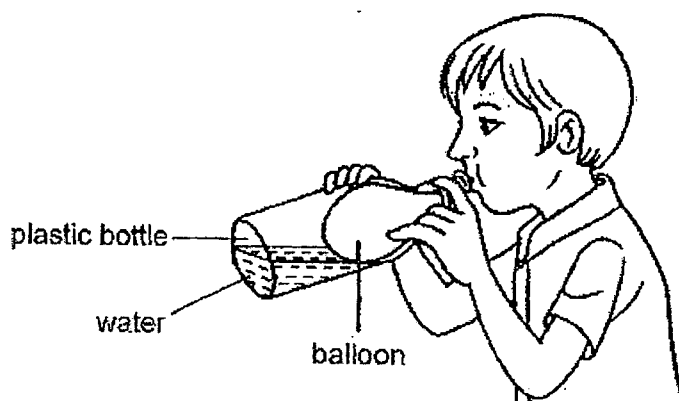

- (a) He found it very difficult to blow into the balloon. Explain why. [2]

Score	2
-------	---

Henry cut a hole into the same plastic bottle as shown below. He used an identical balloon and tried to blow into the balloon.

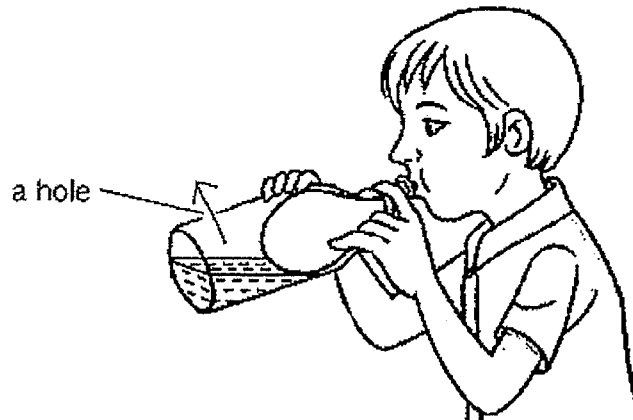

- (b) In the diagram above, draw an arrow (\rightarrow) to show what happens to the air in the bottle when Henry blows air into the balloon. [1]

Henry noticed that the balloon inflated to a bigger size easily. He also observed that the water level rose.

- (c) Why did the water level rise in the bottle? [1]

Score	2
-------	---

32. There are different amounts of dirt particles found in the water of ponds, A, B and C. Tom collected equal volume of water from ponds A, B and C. He set up the following experiment in a dark room as shown below.

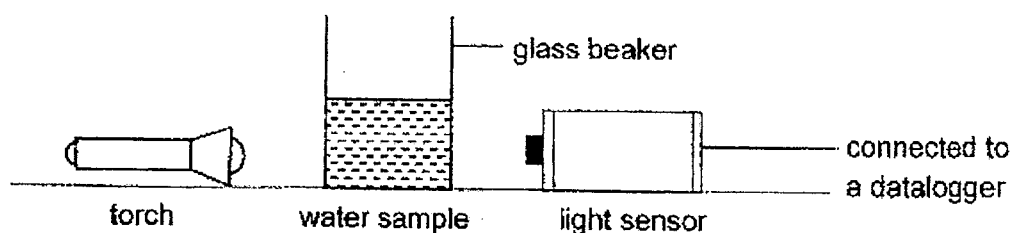

He used the same torch and light sensor to shine light through the identical beakers for the different samples of water. He used the light sensor to measure the amount of light that passed through the water.

Water sample	Amount of light recorded by sensor (units)
None	600
A	350
B	580
C	100

- (a) Explain why the amount of light recorded is the lowest in water sample C. [1]

- (b) State another variable Tom should keep constant in his experiment. [1]

Score	2
-------	---

Tom did another experiment where he placed the coin at the bottom of beaker X as shown below. He then poured water from water sample A into beaker X.

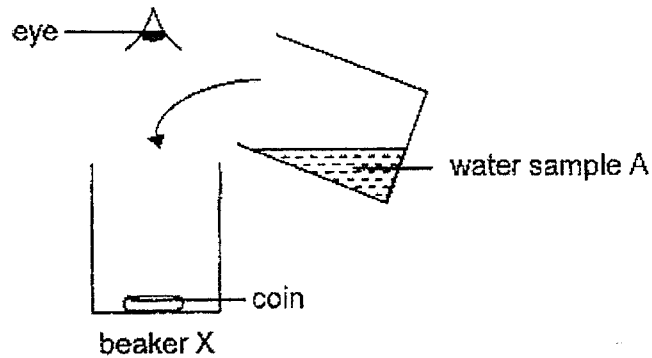

Tom stopped pouring when he could no longer see the coin from the top of the beaker. He measured the amount of water in beaker X before repeating this for water samples B and C.

(c) Based on the results in the previous table, fill in either water samples 'A', 'B' or 'C' in the boxes below. [1]

Water sample	Amount of water poured until the coin could not be seen (ml)
<input type="text"/>	950
<input type="text"/>	550
<input type="text"/>	300

(d) The diagram below shows a glass snow globe with a figurine inside.

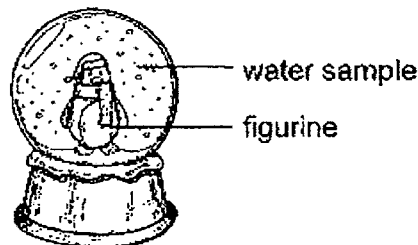

Based on the table given on page 12, which water sample, A, B or C, would be the most suitable to fill the snow globe for users to see the figurine most clearly? [1]

Water sample _____

Score	2
-------	---

33. Desmond conducted an experiment using four different materials, W, X, Y and Z, as shown below. Each material had a cube of identical sized butter placed in it. The materials were then placed on a hot plate at the same time.

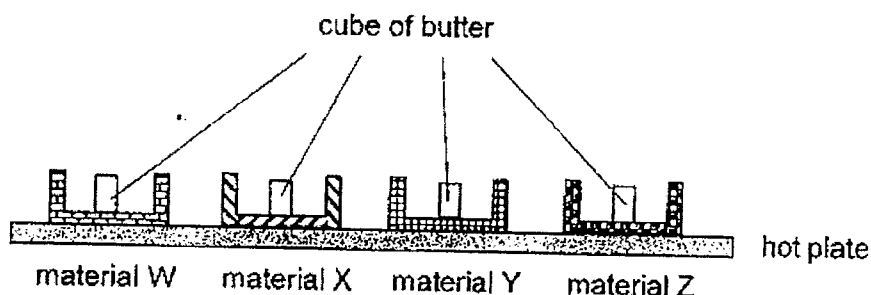

Material	Time taken for the butter to melt completely (min)
W	10
X	7
Y	2
Z	5

- (a) Arrange the four materials, W, X, Y and Z, from the poorest conductor of heat to the best conductor of heat. [1]

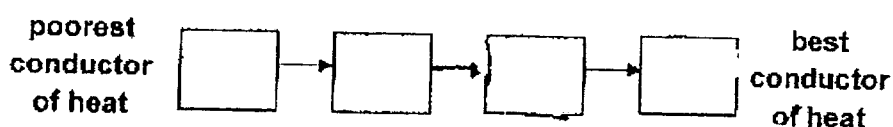

- (b) What can Desmond do to ensure that the results of the experiment are reliable? [1]

Score	2
-------	---

Desmond wanted to have his soup boiled the fastest over a flame.

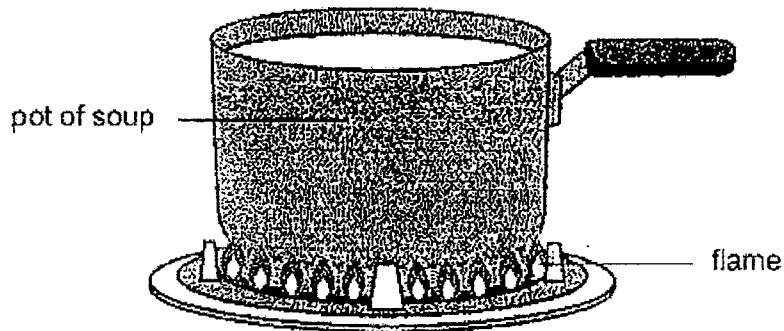

- (c) Based on the results of his experiment, which material, W, X, Y or Z, is most suitable to make the base of the pot? Explain why. [2]

34. Melissa wanted to find out the fastest way to remove a dent on a plastic ping-pong ball. A weight was attached to the ping-pong ball.



She conducted an experiment using the four set-ups, A, B, C and D as shown below. Four ping-pong balls with dents of equal size were taken from a room at room temperature. Each ball was placed into a beaker of water as shown below.

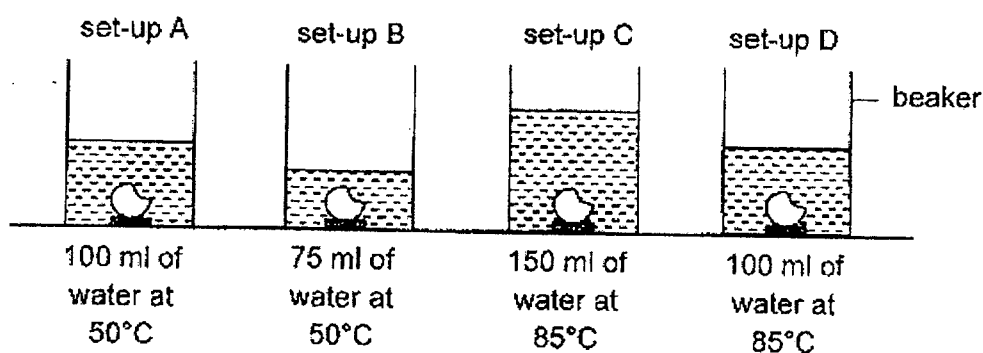

- (a) Explain why the dent on the ping-pong ball could be removed using the above method. [1]

- (b) Melissa observed that the dent on the ping-pong ball in set-up C was removed the fastest. Explain why. [2]

Melissa repeated the experiment with 100 ml of water at room temperature for set-up E as shown below.

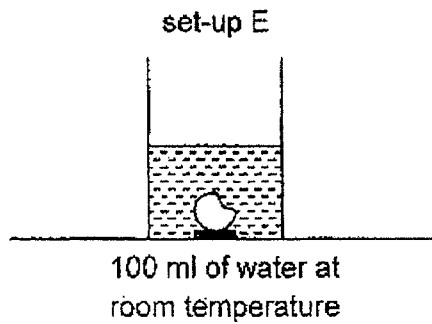

- (c) Explain why the dent in the ping-pong ball could not be removed using set-up E above. [1]

Score	3
-------	---

SCHOOL : TAO NAN PRIMARY SCHOOL

LEVEL : PRIMARY 4

SUBJECT : SCIENCE

TERM : 2022 SA2

SECTION A

Q 1	Q2	Q3	Q4	Q5	Q6	Q7	Q8	Q9	Q10
4	3	3	4	4	2	1	4	2	4

Q 11	Q12	Q13	Q14	Q15	Q16	Q17	Q18	Q19	Q20
2	3	1	2	2	2	1	2	3	3

Q 21	Q22
1	2

Suggested Answer 2022 P4 Science End-of-Year Examination

Booklet B

Qn	Suggested Answer	
23	Plants	Fungi
	tree fern	mould mushroom
24a	Part K: <u>Root(s)</u>	
b	food	
25	(a) pan: solid	(a) oil: liquid
26	light, reflected	
27a	The object is a magnet.	
b	The magnet will attract end U of the object.	
28a	<p>The butterfly has four stages in its life cycle while the grasshopper has three stages in its life cycle.</p> <p>The young of the grasshopper looks like its adult but the young of butterfly does not.</p> <p>The butterfly has a pupa stage that does not feed but the grasshopper does not have this stage.</p>	
b	Seed	
29a	<pre> graph TD A --> B B --> C C --> A A --> D D --> A </pre>	
b	A / Larval stage / Larva The mosquito larva moults to grow in size.	
c	W and Z	
30a	P: Small intestine	Q: Mouth
b	Digestion is completed in the small intestine (P). OR The large intestine does not have digestion.	
c	Cutting up the chicken meat increases the (exposed) surface area of the <u>meat</u> to the digestive juices (c), hence increasing the rate of digestion (e).	
31a	The air and the water in the bottle occupy space (c). After some blowing, the air in the bottle cannot be compressed further (e).	

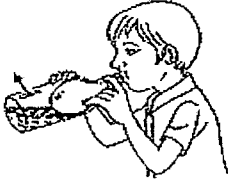
									
c	The balloon occupied the space previously occupied by the water . or The balloon displaced the water in the bottle.								
32a	Water sample C had the most* dirt which blocked most* light preventing it from passing through.								
b	Distance between the torch and light sensor (2 reference points are needed)								
c	<table border="1" style="margin-left: auto; margin-right: auto;"> <thead> <tr> <th style="text-align: center;">Water sample</th> <th style="text-align: center;">Amount of water poured until the coin is not seen (ml)</th> </tr> </thead> <tbody> <tr> <td style="text-align: center;">B</td> <td style="text-align: center;">950</td> </tr> <tr> <td style="text-align: center;">A</td> <td style="text-align: center;">550</td> </tr> <tr> <td style="text-align: center;">C</td> <td style="text-align: center;">300</td> </tr> </tbody> </table>	Water sample	Amount of water poured until the coin is not seen (ml)	B	950	A	550	C	300
Water sample	Amount of water poured until the coin is not seen (ml)								
B	950								
A	550								
C	300								
d	Water sample <u>B</u>								
33a	W, X, Z, Y								
b	He can redo the experiment several times.								
c	<p>Material Y</p> <p>Material Y is the best conductor of heat (given in part (a)). (<u>Claim – Property</u>)</p> <p>The time taken for butter to melt completely is the shortest (<u>Evidence from data</u>)</p> <p>the soup will gain heat the fastest/the most from the flame [heat source] (<u>Reason – application to scenario</u>)</p>								
34a	The air in the ping-pong ball gains heat from the hot water (c) and expands (e)								
b	<p>Set-up C had the most amount of water at the highest temperature.(c) OR</p> <p>The water had the most heat. r.</p> <p>Hence, the air in the ping-pong ball will gain heat the fastest from the hot water (e) and expand the fastest .</p>								
c	<p>The temperature of the water and (the air in) the ping pong ball are the same. (<u>C- Temperature difference</u>)</p> <p>There was no heat gain by the air in the ping-pong ball from the water (<u>e- heat transfer</u>)</p>								

