

METHODIST GIRLS' SCHOOL

Founded in 1887

**END-OF-YEAR EXAMINATION
PRIMARY 4
SCIENCE****BOOKLET A**

Total Time for Booklets A and B: 1 hour 30 minutes

INSTRUCTIONS TO CANDIDATES

Do not turn over this page until you are told to do so.

Follow all instructions carefully.

Answer all questions.

Shade your answers in the Optical Answer Sheet (OAS) provided.

Name: _____

Class: Primary 4. _____

This booklet consists of 18 printed pages including this page.

For each question from 1 to 28, four options are given. One of them is the correct answer. Make your choice (1, 2, 3 or 4). Shade the correct oval on the Optical Answer Sheet (OAS).
[56 marks]

1 Which one of the following is not a living thing?

(1)



(2)



(3)

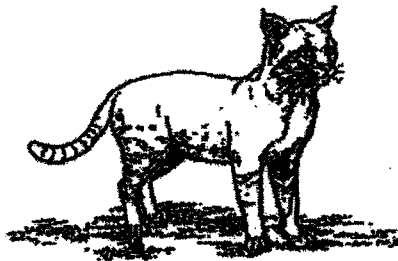

(4)



2 The diagram below shows a dog barking at a butterfly.



This shows that the dog is a living thing because it can _____.

- (1) grow
- (2) breathe
- (3) respond
- (4) reproduce

3 The diagram below shows a water hose connected to a tap.



Water can flow through the coiled water hose because it _____.

- (1) has mass.
- (2) has definite volume.
- (3) has no definite shape.
- (4) cannot be compressed.

4 The chart below shows how substance Z and air are transported in a human body.

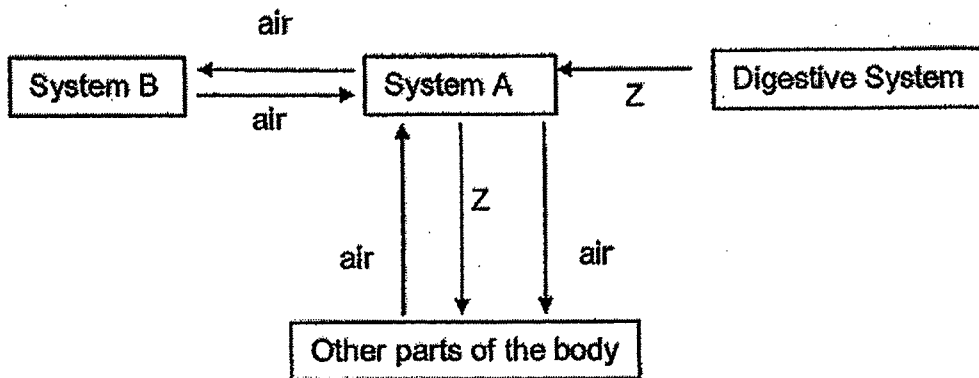

What are systems A and B and substance Z?

	System A	System B	Substance Z
(1)	respiratory	circulatory	digested food
(2)	circulatory	respiratory	digested food
(3)	muscular	circulatory	air
(4)	circulatory	respiratory	air

5 Study the chart below.

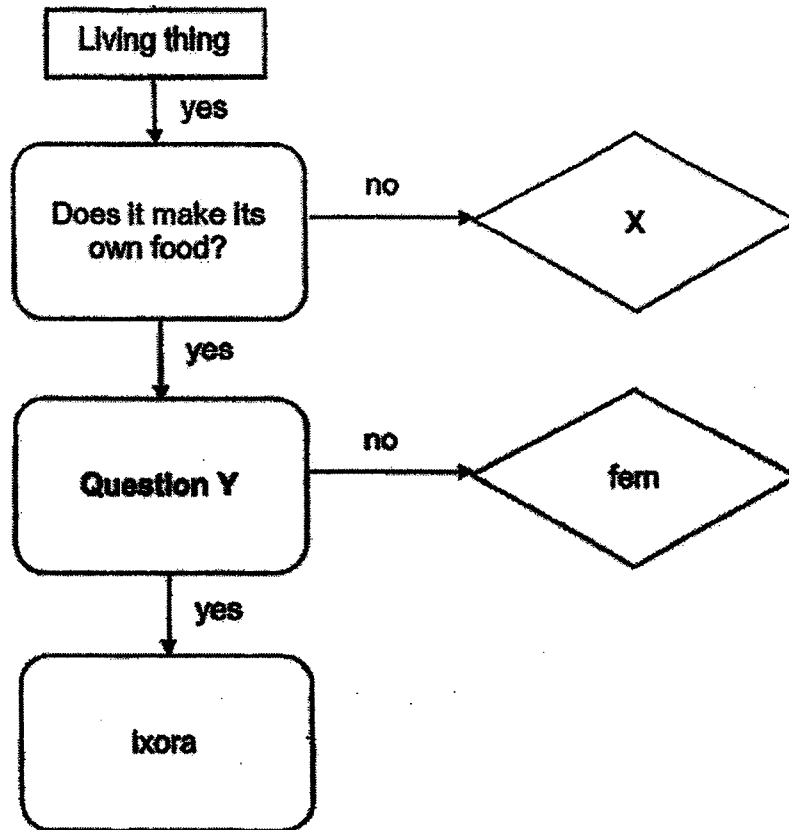

Which one of the following is correct?

	X	Question Y
(1)	mould	Does it produce seeds?
(2)	mushroom	Does it have roots?
(3)	moss	Does it have fruits?
(4)	rose	Does it need water?

6 Which part of the human digestive system listed below absorbs all the remaining digested food?

- (1) stomach
- (2) small intestine
- (3) large intestine
- (4) anus

7 Which one of the following is not matter?

- (1) star
- (2) sound
- (3) smoke
- (4) sponge

8 The diagram below shows two plants.

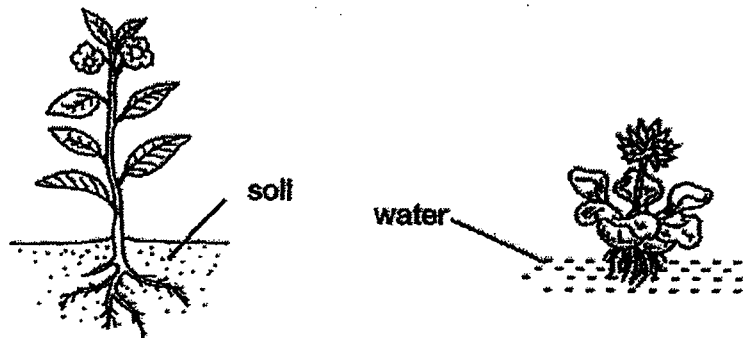

Which one of the following statements explains correctly the function of roots for both the plants above?

- (1) The roots support the plants upright.
- (2) The roots take in mineral salts for the plants.
- (3) The roots hold the plants firmly to the ground.
- (4) The roots spread out to receive more sunlight.

- 9 Ms Tan prepared three set-ups, X, Y and Z, using identical plants as shown in the diagram below. Each container had the same amount of water and a layer of oil. Ms Tan placed the three set-ups near a window and observed the amount of water left in the beaker after a week.

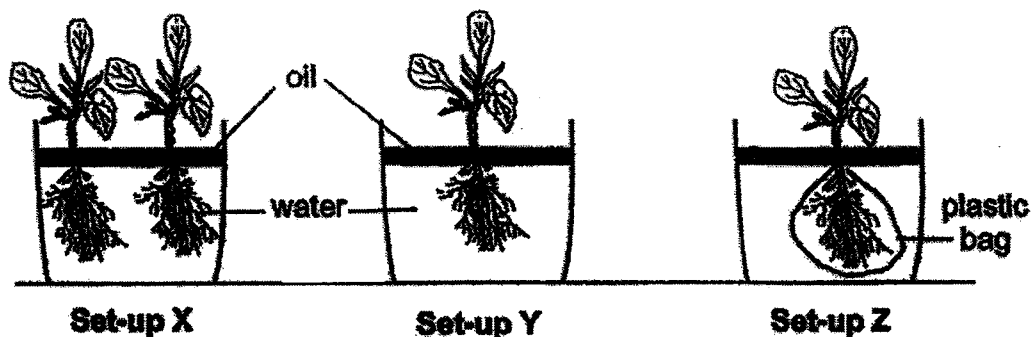

Which one of the following most likely shows the amount of water left in each container at the end of a week?

(1)

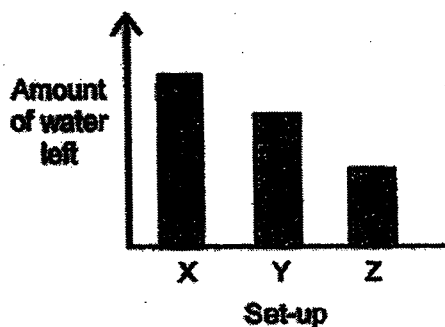

(2)

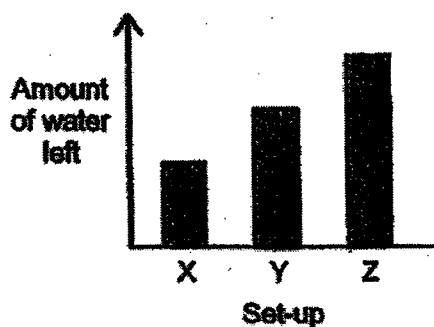

(3)

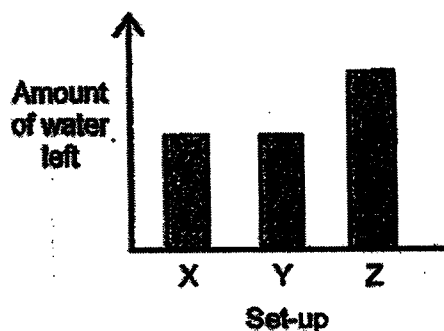

(4)

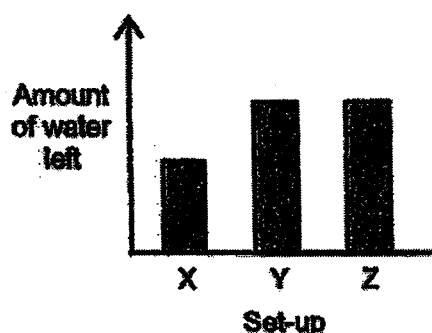

- 10 The diagram below shows the life cycle of an animal.

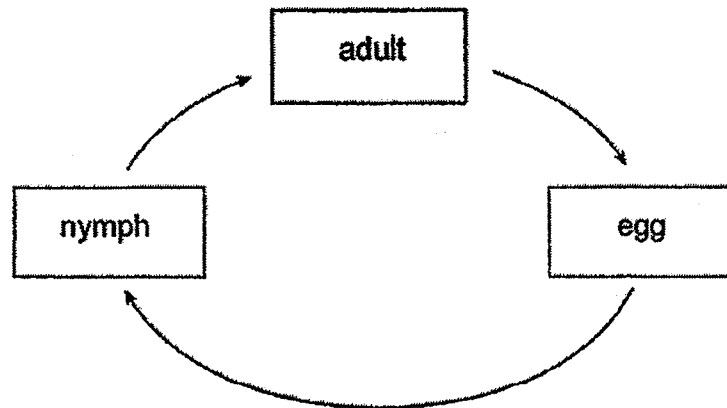

Which animal is likely to have the life cycle as shown above?

- (1) chicken
 - (2) frog
 - (3) housefly
 - (4) cockroach
- 11 The diagram below shows stages in the life cycle of an insect.

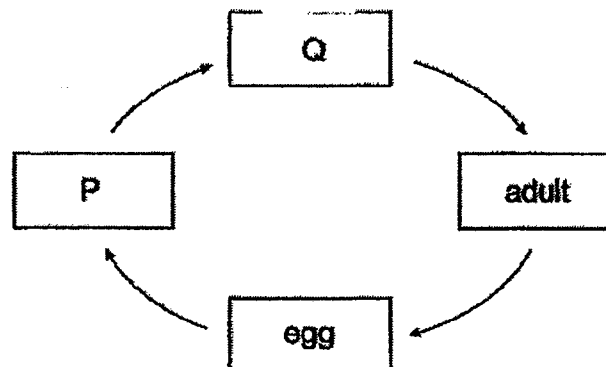

Which of the following correctly describes the insect at stages P and Q?

	Stage P	Stage Q
(1)	moves a lot	does not move
(2)	looks like adult	does not look like adult
(3)	does not moult	moults several times
(4)	able to fly	unable to fly

- 12 John filled a syringe with some oil and air. He covered one end of the syringe and tried to push the plunger down.

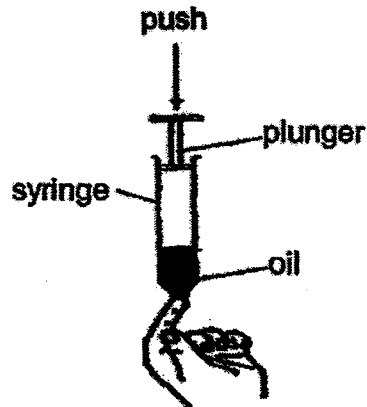

John could not push in the plunger completely. Which of the following explain his observation?

- A Air takes up space.
- B Oil has a definite volume.
- C Oil has no definite shape.
- D Air has no definite shape.

- (1) A and B only
- (2) A and D only
- (3) B and C only
- (4) C and D only

- 13 The animals are classified into two groups as shown below.

Group Y	Group Z
mosquito	grasshopper
mealworm beetle	chicken

What is/are the possible heading(s) for groups Y and Z?

	Group Y	Group Z
A	The young do not resemble adult	The young resemble adult
B	Have wings in the adult stage	Do not have wings in the adult stage
C	Spend part of the life cycle in water	Spend the whole life cycle on land

- (1) A only
- (2) B only
- (3) B and C only
- (4) A and C only

14 Study the flowchart below.

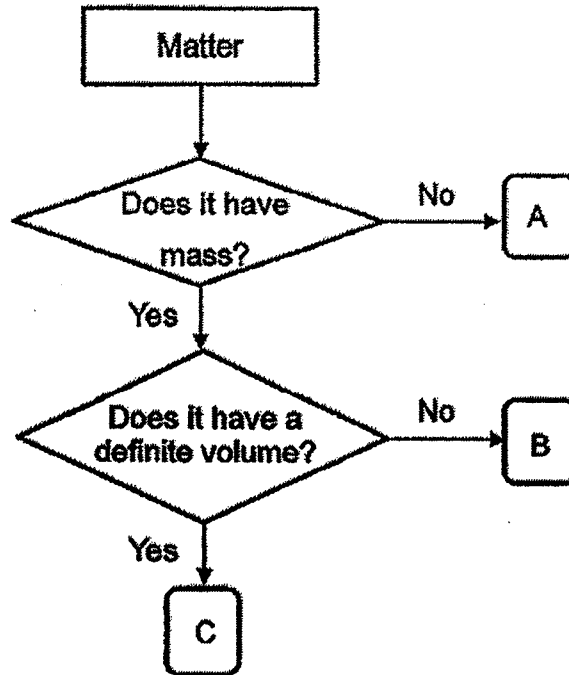

Which one of the following best represents A, B and C?

	A	B	C
(1)	air	oxygen	ice
(2)	heat	water	air
(3)	shadow	oxygen	ice
(4)	light	ice	air

15 The diagram below shows a shelf.

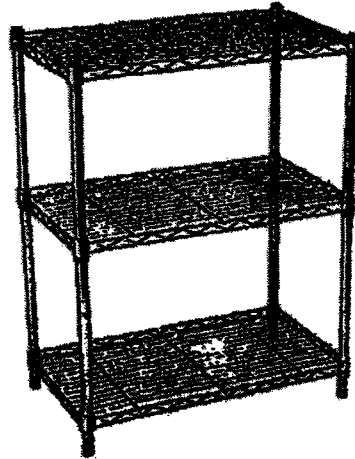

Metal is used to make the shelf because metal _____.

- (1) is shiny
- (2) can reflect light
- (3) does not break easily
- (4) is a good conductor of heat

16 Which one of the following can be attracted by a magnet?

- (1) steel ruler
- (2) rubber ball
- (3) glass marble
- (4) wooden spoon

17 Which one of the following is a source of light?

(1)



a mirror

(2)

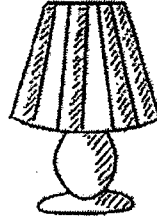

a lamp

(3)

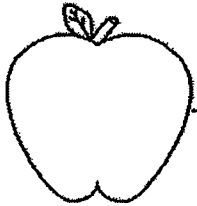

an apple

(4)



the moon.

18 Which diagram below shows repulsion between two magnets?

(1)

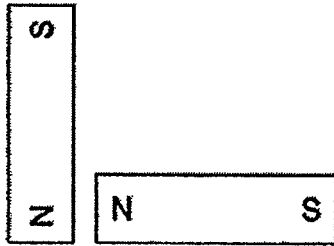

(2)

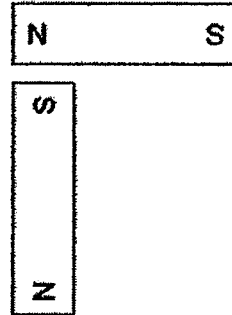

(3)

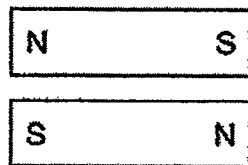

(4)



- 19 Zakiah placed an ice cube into a cup of water as shown below.

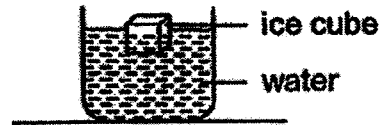

The ice melted after a while.

Which one of the following explains Zakiah's observation?

- (1) The cup loses heat to the water.
 - (2) The water gains heat from the ice.
 - (3) The ice cube gains heat from the water.
 - (4) The ice cube loses heat from the water.
- 20 Bar C, D, E and F were hung on a rod and the observations are shown below.

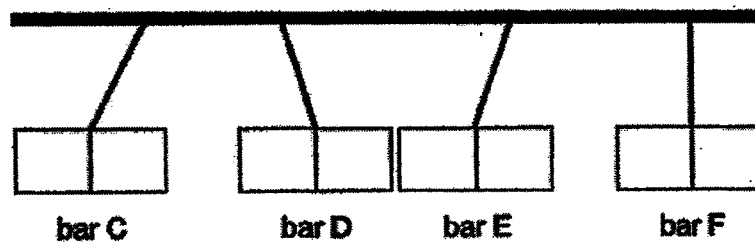

Which of the following statements are true?

- W Bar C is a magnet.
- X Bar D is made of copper.
- Y Bar E can be a magnetic material.
- Z Bar F can be a non-magnetic material.

- (1) W and Z only
- (2) X and Y only
- (3) W, Y and Z only
- (4) All of the above

- 21 Four identical cubes made of different materials, A, B, C and D, were weighed before they were placed into four containers containing equal amount of water.

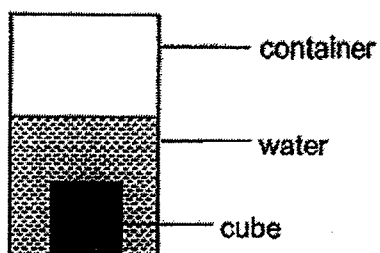

After 10 minutes, each cube was weighed again. Their masses were recorded in the table below.

Material	Mass at the beginning (g)	Mass after 10 minutes
A	12	14
B	7	14
C	13	18
D	10	10

Which material is the most suitable to make a raincoat and towel?

	Raincoat	Towel
(1)	A	C
(2)	B	D
(3)	C	D
(4)	D	B

- 22 Two empty flasks, P and Q, are connected by a glass tube as shown below. There is a drop of ink in the tube.

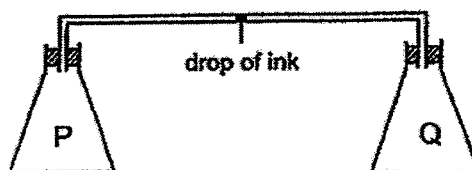

Which of the following actions will cause the drop of ink to move towards flask P?

- W Place flask P in a basin of ice.
- X Place flask Q in a basin of ice.
- Y Place flask P in a basin of hot water.
- Z Place flask Q in a basin of hot water.

- (1) W and X only
- (2) X and Y only
- (3) W and Z only
- (4) Y and Z only

- 23 Melting heated cube G and H to the same temperature as shown below. Cube G and H are made of the same material.

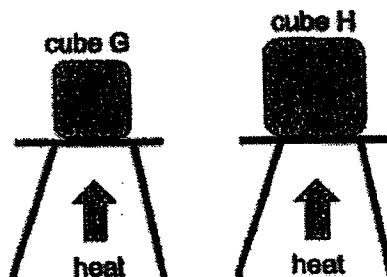

Which one of the following statements is correct?

- (1) Cube G has more heat energy as it gained heat faster.
- (2) Cube G has less heat energy as compared to cube H.
- (3) Cube H has less heat energy as compared to cube G.
- (4) Cube H has more heat energy as it lost heat faster.

24 The diagram below shows blobs of wax, A, B, C and D, which are placed onto a triangular piece of metal.

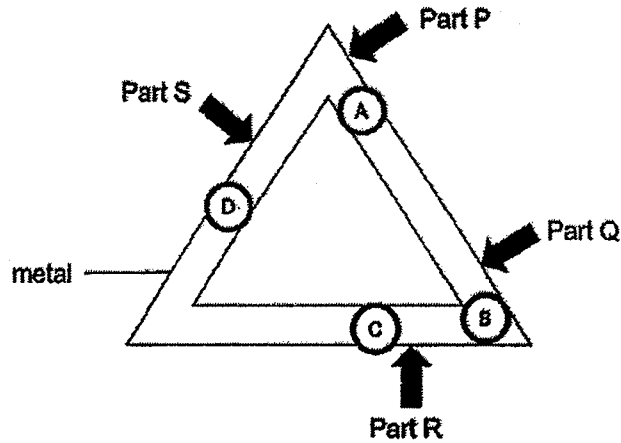

When a certain position of the metal piece is heated, the blobs of wax melt in the order of B, C, A, D. Which position, P, Q, R or S, is the metal piece heated?

- (1) P
- (2) Q
- (3) R
- (4) S

25 A cup of hot chocolate was left in a room for 40 minutes. Which one of the graphs represents the changes in temperature that took place in the cup of hot chocolate?

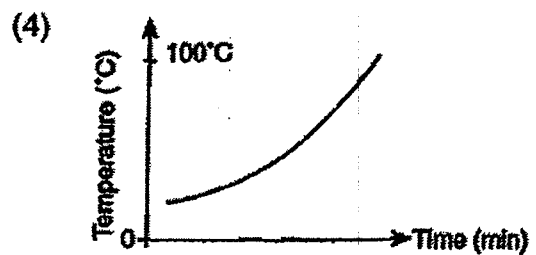
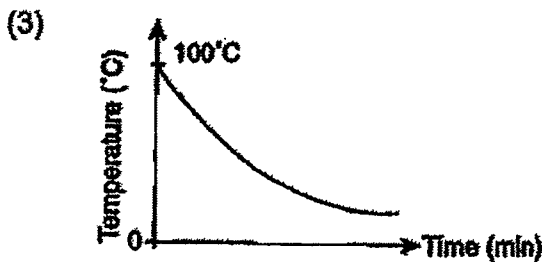
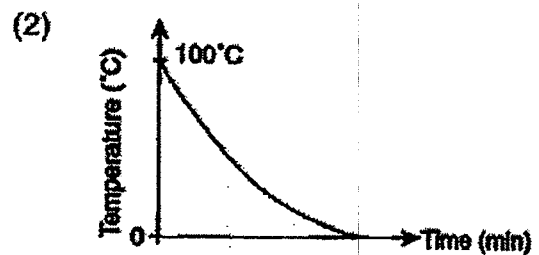
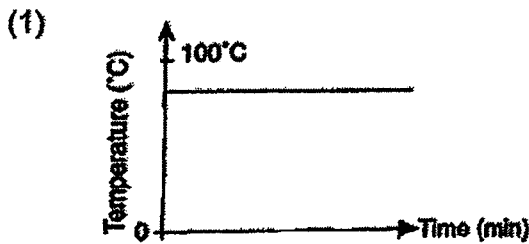

- 26 Nalini cut out three shapes that are of the same height from a piece of cardboard.

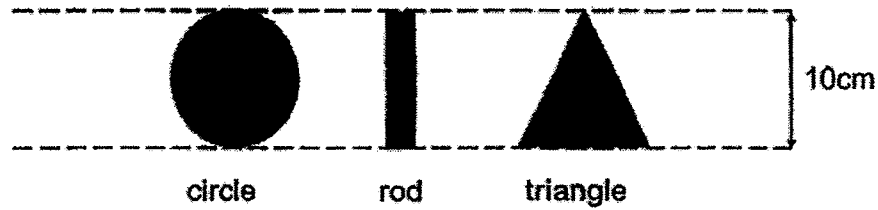

She placed each shape at different positions, X, Y and Z and a shadow is formed on the screen as shown below.

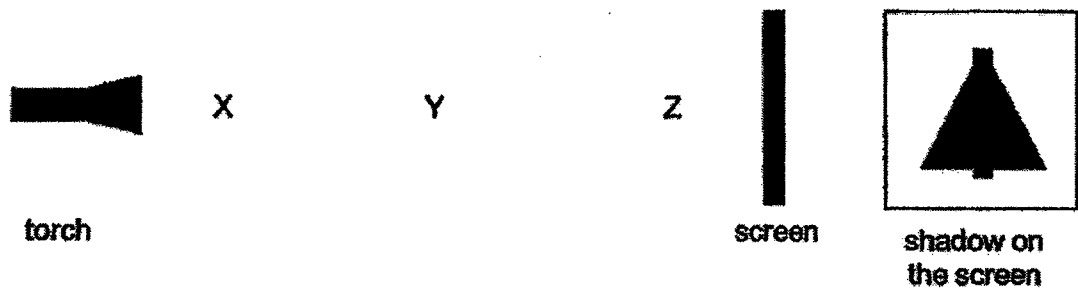

Which one of the following shows the objects placed at positions X, Y and Z?

	X	Y	Z
(1)	rod	circle	triangle
(2)	triangle	rod	circle
(3)	rod	triangle	circle
(4)	circle	triangle	rod

27 Ron placed object W behind three different materials, R, S and T.

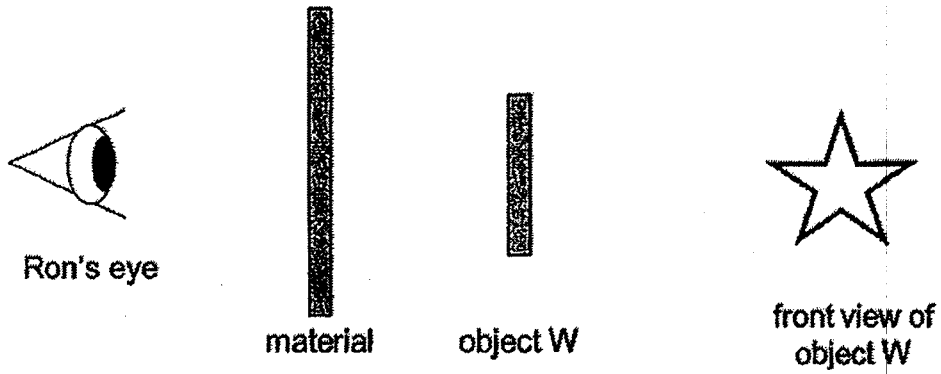

He drew what he could see as shown below.

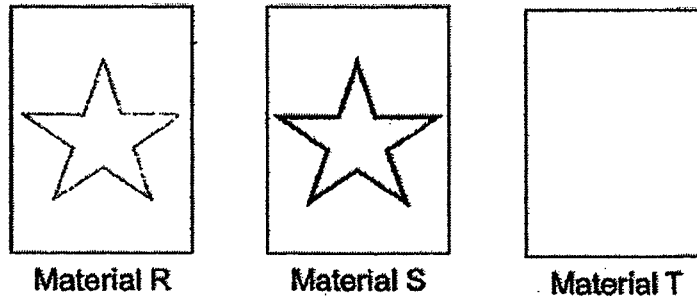



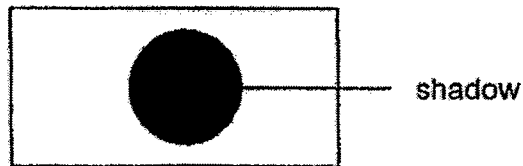

Which one of the following properties describe the materials correctly?

	No light can pass through	Some light can pass through	Most light can pass through
(1)	R	S	T
(2)	T	R	S
(3)	S	R	T
(4)	T	S	R

- 28 An object was placed in front of a light source. A shadow was formed on the screen as shown below.



Which one of the following objects could form the above shadow?

			
bottle	toilet roll	thumbtack	cone

- (1) toilet roll and cone only
- (2) bottle and thumbtack only
- (3) bottle, thumbtack and cone only
- (4) toilet roll, thumbtack and cone only

METHODIST GIRLS' SCHOOL
 Founded in 1887



END-OF-YEAR EXAMINATION
PRIMARY 4
SCIENCE
BOOKLET B

Total Time for Booklets A and B: 1 hour 30 minutes

INSTRUCTIONS TO CANDIDATES

Do not turn over this page until you are told to do so.
Follow all instructions carefully.
Answer all questions.

Name: _____ ()

Class: Primary 4. _____

Booklet A	56
Booklet B	34
Total	90
Parent's Signature	

This booklet consists of 12 printed pages including this page.

For questions 29 to 40, write your answers in the spaces provided. The number of marks available is shown in brackets [] at the end of each question or part question.

[34 marks]

- 29 Two objects, A and H, made of different materials were placed on a balance as shown below.

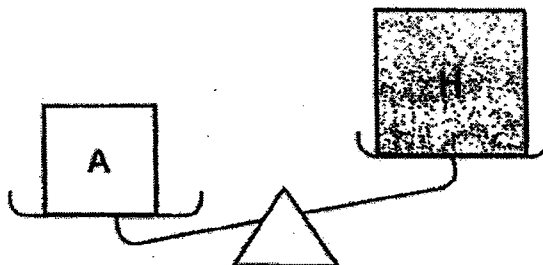

What could be concluded based on the above set-up using the balance?
Circle the correct answers for (a).

- (a) The mass / volume of the Object A is [1]
greater than / the same as / smaller than Object H. [1]
- (b) Then, the two objects were placed into two identical beakers, P and Q, containing the same amount of water as shown below.

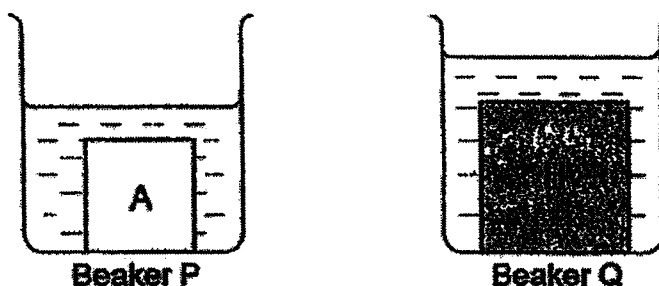

Why is the water level in beaker Q higher than the water level in beaker P? [1]

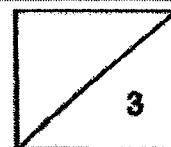

(Go on to the next page)

30 The diagram below shows the human digestive system.

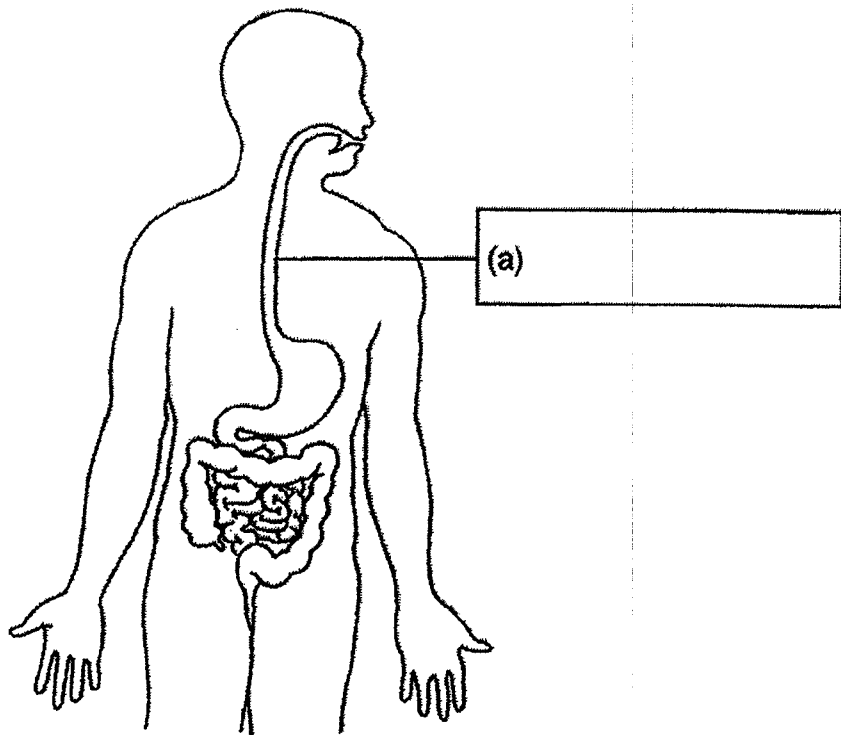

- (a)** Name the organ in (a) by writing your answer in the box above. [1]
- (b)** Name another organ in the human digestive system where digestion does not take place. [1]

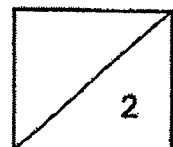

(Go on to the next page)

- 31 Study the life cycle of the butterfly and frog as shown below.

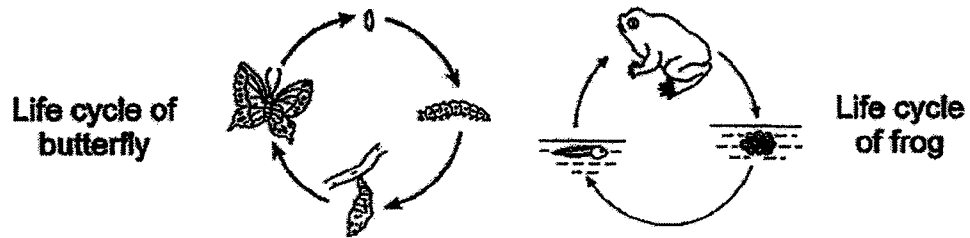

- (a) State a difference between the number of stages in the life cycles of the butterfly and the frog. [1]

- (b) Siti placed a caterpillar into a tank filled with leaves. She left the caterpillar in the tank until it developed into a butterfly. She measured the mass of leaves left in the tank and recorded her results as shown in the graph below.

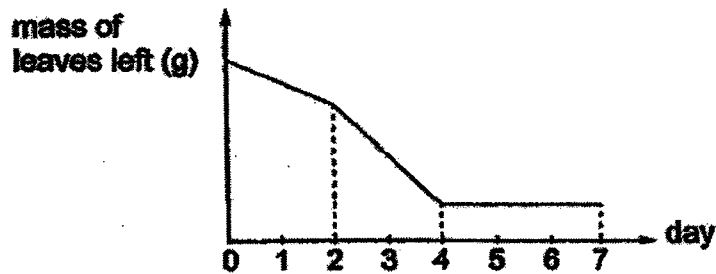

- When did the caterpillar turned into a pupa? Explain your answer clearly. [2]

- (c) It had not been raining for many months and the pond in Siti's garden was drying up. Siti noticed that there were fewer frogs in the pond. Based on the life cycle of frog given above, give a reason for Siti's observation. [1]



(Go on to the next page)

32 Bala conducted an experiment as shown below to find out if the amount of light affects the growth of seeds. He placed one of the set-ups in the open field and the other in the kitchen.

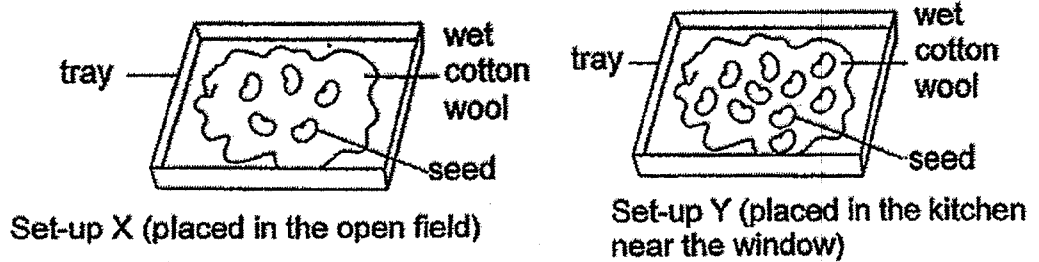

(a) Bala's sister told him that his experiment was not fair. Suggest two changes that Bala should make to set-up Y so that the experiment is fair. [2]

Suggestion 1: _____

Suggestion 2: _____

(b) Bala observed the stages of development of his seed.

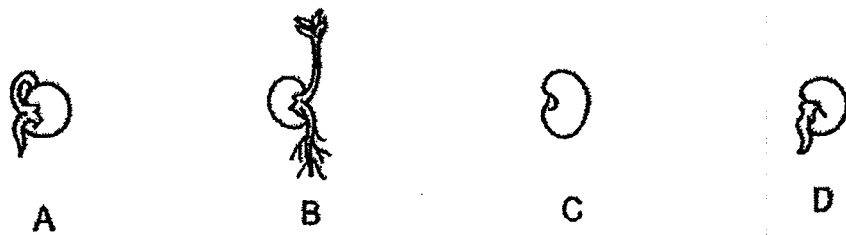

Arrange the stages in the correct order of development from the seed to a seedling. Fill in the boxes provided below with letters, A, B, C and D. [1]

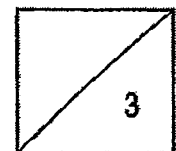

(Go on to the next page)

- 33 Wenli filled a beaker with water to the brim as shown in the diagram below. She then dropped a steel ball into the beaker.

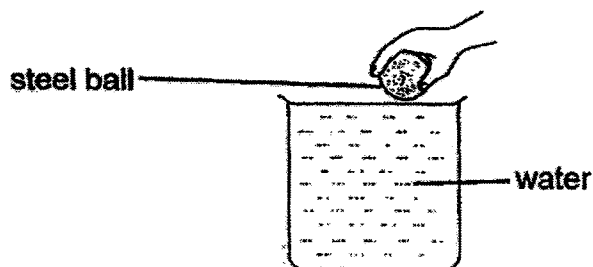

- (a) What would Wenli observe about the water after she dropped the steel ball into the beaker? [1]

- (b) What property of matter was shown in the experiment above? [1]

Wenli transferred a Matter Z from the measuring cylinder to a beaker as shown below and she observed the following result.

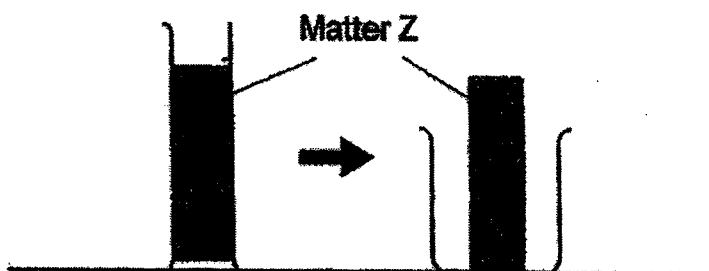

- (c) What is the state of Matter Z? Explain your answer. [2]

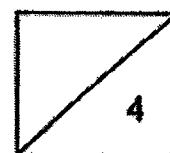

(Go on to the next page)

34 The diagram below shows an oven.

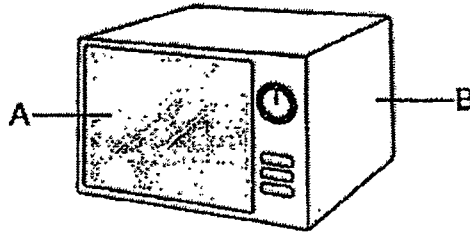

- (a) Part A is made of glass because it allows _____ to pass through so that the user can see the dish inside. [1]
- (b) Part B is made of _____ because it needs to be strong. [1]

35 Bala used an instrument to measure the temperature of water in a beaker.

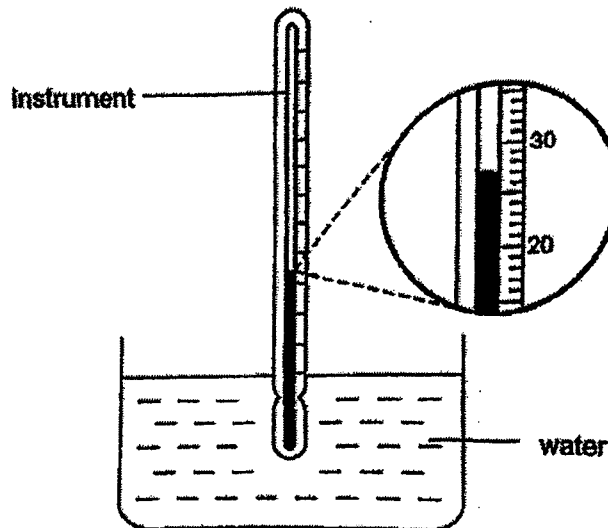

- (a) What is the instrument called? [1]

- (b) What is the temperature of the water in the beaker? [1]

_____ °C

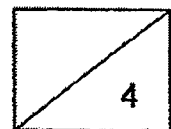

(Go on to the next page)

- 36 The diagram below shows how a person sees the flower.

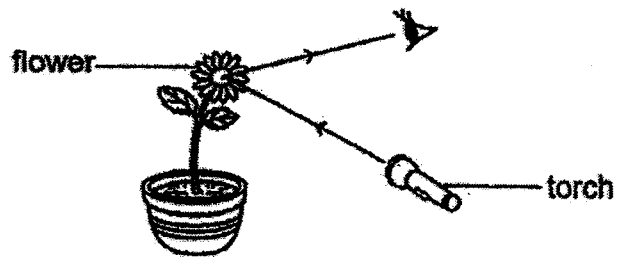

The _____ from the torch is _____ by the
flower and enters the person's eye. [2]

- 37 Janet took out two glasses, P and Q, from her cupboard and she found that the glasses were stuck together.

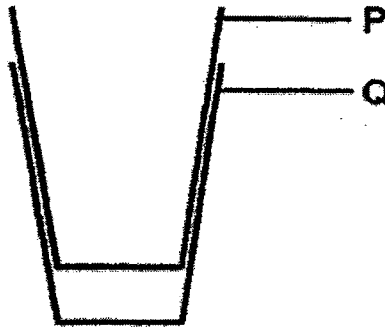

Janet decided to pour hot water on glass P to separate them but it did not work.
Explain why. [2]

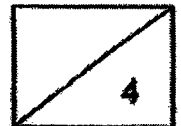

(Go on to the next page)

- 38 An experiment was set up as shown below. One ice cube of equal volume was placed in container X, Y and Z at room temperature. Container X, Y and Z are made of different materials.

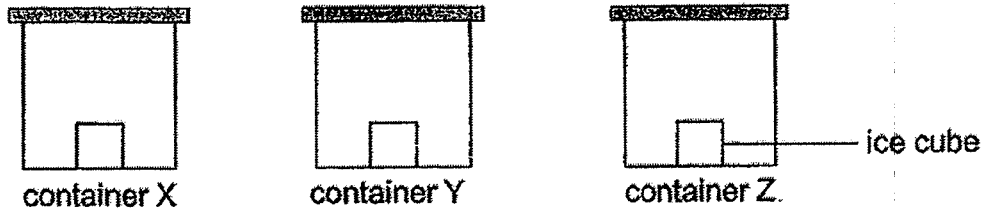

After 30 minutes, the ice cubes were removed from each container. The amount of water collected in each container was measured. The results are shown in the graph below.

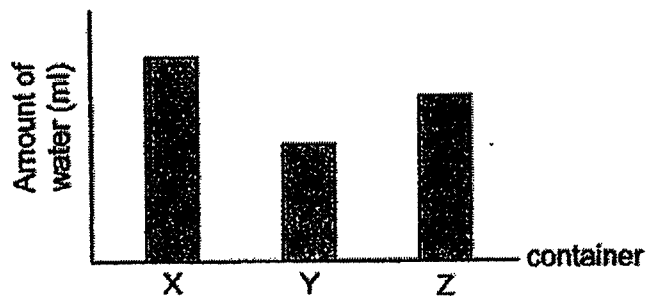

- (a) What is the change in state of the ice cubes in the containers after 30 minutes? [1]
-
- (b) Which container, X, Y or Z caused the ice cubes to melt the slowest? Explain your answer based on the graph above. [1]
-
- (c) What property of the container you have chosen in (b) caused the ice cube to melt the slowest? [1]
-

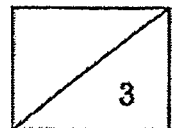

(Go on to the next page)

- 39 The diagram below shows a set up to measure the amount of light that could pass through different materials, R, S and T.

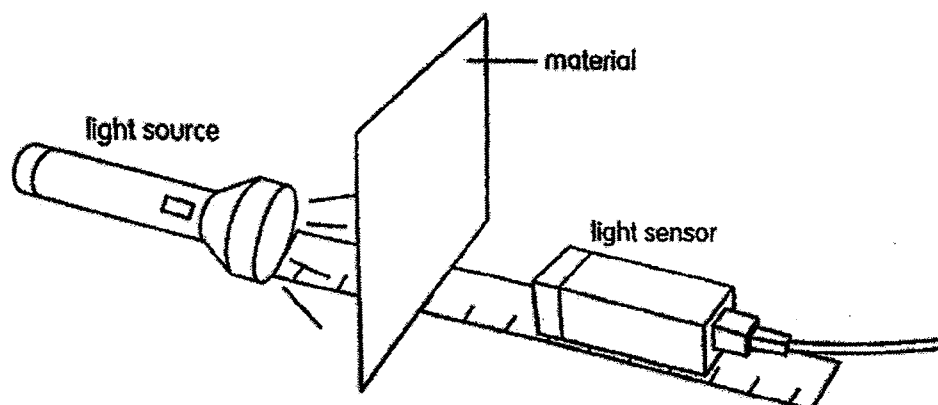

The table below shows the amount of light that passed through different materials, R, S and T.

Material	Amount of light (units)
no material	100
R	0
S	60
T	98

The picture below shows a pair of sunglasses.

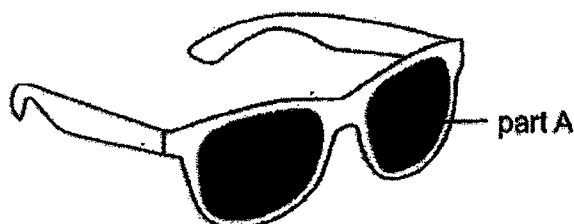

- (a) Based on the results, which material R, S or T, would be suitable to make Part A of the sunglasses? [1]

Material _____

- (b) Explain your answer based on the results above. [1]

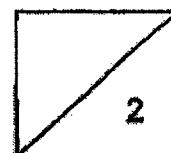

(Go on to the next page)

Material R was used in another experimental set up as shown below. A shadow was formed on the screen when the torch was switched on.

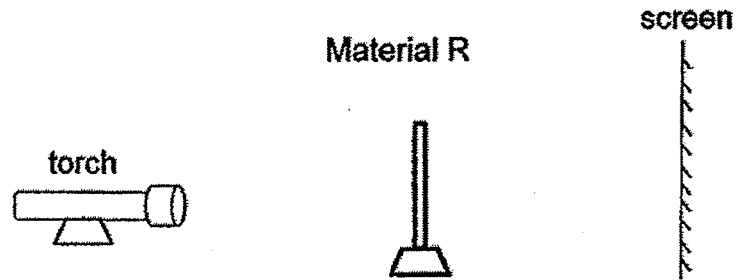

- (c) What would happen to the shadow if material R is moved nearer to the torch? [1]

- (d) Explain your answer in (c). [1]

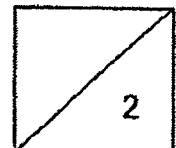

(Go on to the next page)

- 40 Roy prepared an electromagnet set-up as shown below.

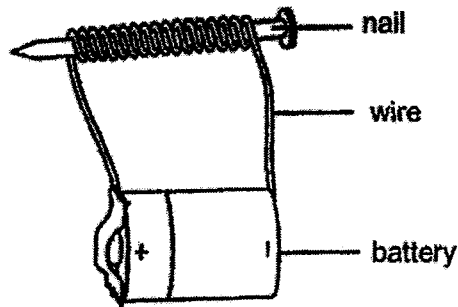

He used nails made of different types of materials, A, B and C, to find out how many pins they could attract. The results are shown below.

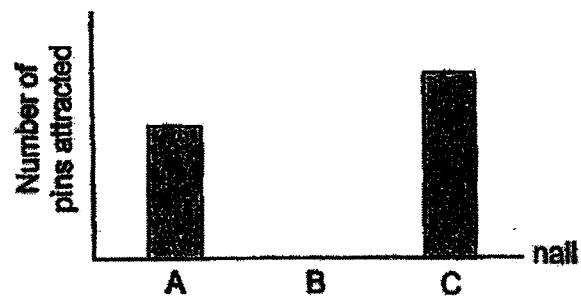

- (a) Which nail, A, B or C, should Roy choose if he wanted to make a stronger electromagnet? Explain your answer. [1]

- (b) Suggest one way that Roy could do to the electromagnet to increase the number of pins attracted to it. [1]

- (c) What could nail B be made of? Explain your answer. [1]

SCHOOL : MGS PRIMARY SCHOOL

LEVEL : PRIMARY 4

SUBJECT : SCIENCE

TERM : 2022 SA2

CONTACT :

SECTION A

Q 1	Q2	Q3	Q4	Q5	Q6	Q7	Q8	Q9	Q10
2	3	3	2	1	2	2	2	2	4

Q 11	Q12	Q13	Q14	Q15	Q16	Q17	Q18	Q19	Q20
1	1	1	3	3	1	2	1	3	3

Q 21	Q22	Q23	Q24	Q25	Q26	Q27	Q28
4	3	2	2	3	3	2	2

Q29)	a)mass / greater than b)Both objects are solid and solid occupy space. Object H has a greater volume than object A, indicating that B occupies more space in the water than A. Hence, the water level in beaker Q would be higher than the water level in P.
Q30)	a)gullet b)Large intestine

Q31)	<p>a)The frog has a three-stages life cycle while the butterfly has a four-stage life cycle.</p> <p>b)Day 4. When the caterpillar was in the larva stage, it will eat a lot as shown in the graph from Day 1 to Day 3. However the mass of leaves remained constant from Day 4 to 7. Indicating that had turned into a pupa which does not move to feed on the leaves.</p> <p>c)The adult frog lays eggs in water. Since the pond is drying up, lesser adult frog will reproduce in the pond. Hence, there would be fewer frogs.</p>
Q32)	<p>a)1)Decrease the number of seeds in Set-up Y to be the same as the number of seeds in Set-up X.</p> <p>2)Place Set-up Y somewhere dark, where there is no light.</p> <p>b) C→D→A→B</p>
Q33)	<p>a)The water in the beaker will overflow.</p> <p>b)Matter has volume and occupies space.</p> <p>c)Solid. Solid has a definite shape and does not take the shape of its container. Matter 2 remained its shape in a rectangle when it was transferred to the beaker.</p>
Q34)	<p>a)light</p> <p>b)metal</p>
Q35)	<p>a)Thermometer</p> <p>b)27°C</p>
Q36)	light / reflected
Q37)	<p>When matter gains heat, it expands. The cup is a matter. When cup P gained heat from the hot water, it expanded and became bigger .</p> <p>Causing both cups to remain stuck.</p>

Q38)	<p>a) From solid state to liquid state.</p> <p>b) Y. The water collected in Y was the least, indicating that it is the poorest conductor of heat and conducts heat from the surrounding to the ice at the slowest rate. Causing the ice to melt the slowest.</p> <p>c) It is the poorest conductor of heat and conducts heat from the surrounding to the ice at the slowest rate compared to X and Z.</p>
Q39)	<p>a) S</p> <p>b) Material S allows some light to pass through.</p> <p>c) It will become bigger.</p> <p>d) More light will be blocked.</p>
Q40)	<p>a) C. The number of pins attracted by C was the most, indicating that C has the strongest magnetic strength among all three materials. A stronger electromagnet must have a stronger magnetic strength.</p> <p>b) Increase the number of batteries in the set-up.</p> <p>c) Aluminium. Nail B did not attract any nails indicating that it is made of a non-magnetic material. Aluminium is non-magnetic.</p>