



RAFFLES GIRLS' PRIMARY SCHOOL  
END OF YEAR EXAMINATION  
PRIMARY FIVE  
2023

MATHEMATICS  
PAPER 1  
(BOOKLET A)

Name: \_\_\_\_\_

Date: 24 October 2023

Class: P5 \_\_\_\_\_

Total Time: 1 hour

Math Teacher's name: \_\_\_\_\_

**INSTRUCTIONS TO CANDIDATES**

1. Do not turn over this page until you are told to do so.
2. Follow all instructions carefully.
3. Answer all questions.
4. Use a 2B pencil to shade your answers on the Optical Answer Sheet (OAS).
5. The use of calculators is NOT allowed.

|                           |    |
|---------------------------|----|
| Paper 1                   | 45 |
| Paper 2                   | 55 |
| Total Score<br>out of 100 |    |
| Parent's<br>signature     |    |

Questions 1 to 10 carry 1 mark each. Questions 11 to 15 carry 2 marks each.  
 For each question, four options are given. One of them is the correct answer.  
 Make your choice (1, 2, 3 or 4) and shade your answer on the Optical Answer Sheet.  
 (20 marks)

1. What is the value of the digit 3 in 30 625?

- (1) 30
- (2) 300
- (3) 3000
- (4) 30 000

2. Express  $1\frac{1}{50}$  as a decimal.

- (1) 1.1
- (2) 1.2
- (3) 1.02
- (4) 1.15

3. Which of the following shows  $\frac{1}{4}$  of the figure shaded?

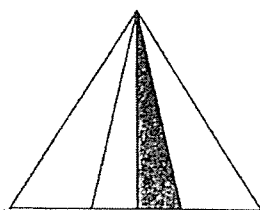

(1)

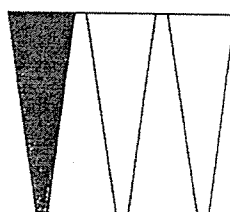

(2)

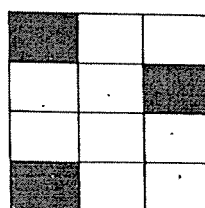

(3)

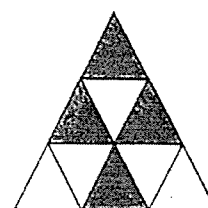

(4)

4. What fraction of the apples are unshaded?

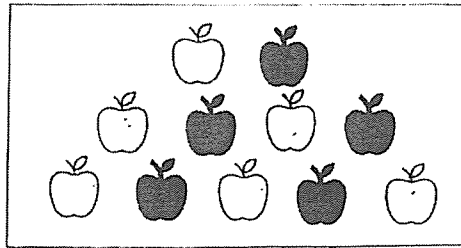

- (1)  $\frac{1}{2}$
- (2)  $\frac{5}{6}$
- (3)  $\frac{5}{11}$
- (4)  $\frac{6}{11}$
5. Arrange the following fractions from the largest to the smallest.

- |     | <u>Largest</u>  |   | <u>Smallest</u> |   |                 |
|-----|-----------------|---|-----------------|---|-----------------|
| (1) | $\frac{11}{12}$ | , | $\frac{2}{3}$   | , | $\frac{3}{4}$   |
| (2) | $\frac{11}{12}$ | , | $\frac{3}{4}$   | , | $\frac{2}{3}$   |
| (3) | $\frac{3}{4}$   | , | $\frac{2}{3}$   | , | $\frac{11}{12}$ |
| (4) | $\frac{3}{4}$   | , | $\frac{11}{12}$ | , | $\frac{2}{3}$   |

6. In triangle ABC, if the base is AB, the height is \_\_\_\_\_.

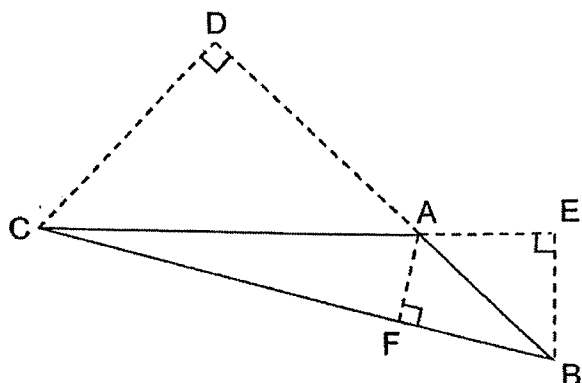

- (1) AE
- (2) AF
- (3) CD
- (4) EB

7. Which line in the square grid is parallel to CD?

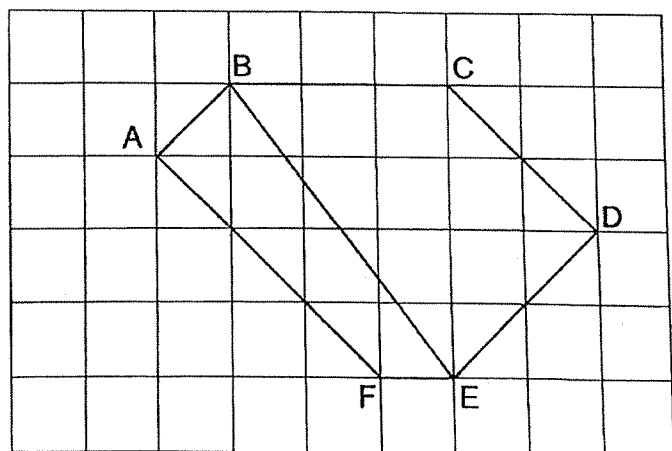

- (1) AF
- (2) BC
- (3) BE
- (4) DE

8. In the figure, how many of the five marked angles are less than  $90^\circ$ ?

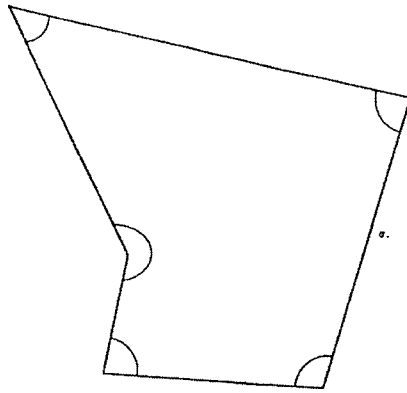

- (1) 5  
(2) 2  
(3) 3  
(4) 4
9. What is the value of  $30 - (6 + 12) \div 2 \times 3$ ?
- (1) 18  
(2) 2  
(3) 3  
(4) 27
10. Maya folds 10 stars in 5 minutes.  
At this rate, how many stars can Maya fold in 20 minutes?
- (1) 10  
(2) 40  
(3) 50  
(4) 200

11. In the number line, what is the value represented by A?

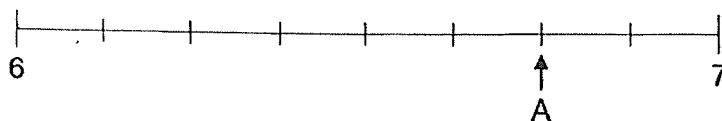

- (1) 6.60
- (2) 6.75
- (3) 7.20
- (4) 7.25

12. The figure shows a cuboid with a square base and a height of 10 cm. The perimeter of the square base is 36 cm. What is the volume of the cuboid?

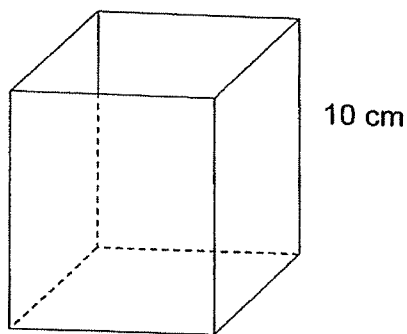

- (1)  $60 \text{ cm}^3$
- (2)  $90 \text{ cm}^3$
- (3)  $360 \text{ cm}^3$
- (4)  $810 \text{ cm}^3$

13. In the figure, BDE is an isosceles triangle. Find  $\angle BDC$ .

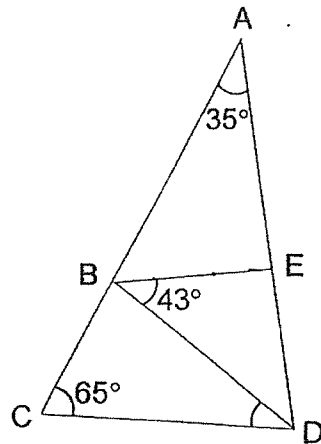

- (1)  $37^\circ$   
 (2)  $43^\circ$   
 (3)  $65^\circ$   
 (4)  $80^\circ$
14. Mr Hamid wanted to transfer 12 of his plants into bigger pots. He used  $\frac{3}{8}$  kg of soil to fill each big pot. He ran out of soil after transferring 5 plants. How much more soil would he need to fill the big pots for the remaining plants?

- (1)  $1\frac{7}{8}$  kg  
 (2)  $2\frac{5}{8}$  kg  
 (3)  $4\frac{1}{2}$  kg  
 (4)  $4\frac{5}{8}$  kg



15. Ally and Bella had the same amount of money at first. After Ally spent \$20 and Bella spent \$80, Ally had 3 times as much money as Bella. How much money did Bella have at first?

- (1) \$100
- (2) \$110
- (3) \$140
- (4) \$220

(Go on to Booklet B)

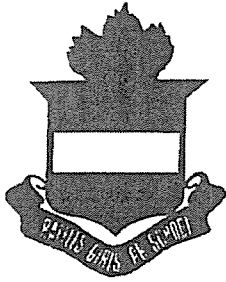

**RAFFLES GIRLS' PRIMARY SCHOOL  
END OF YEAR EXAMINATION  
PRIMARY FIVE  
2023**

**MATHEMATICS  
PAPER 1  
(BOOKLET B)**

Name: \_\_\_\_\_

Date: 24 October 2023

Class: P5 \_\_\_\_\_

Total Time: 1 hour

Math Teacher's Name: \_\_\_\_\_

**INSTRUCTIONS TO CANDIDATES**

1. Do not turn over this page until you are told to do so.
2. Follow all instructions carefully.
3. Answer all questions.
4. Use a dark blue or black ballpoint pen to write your answers in the space provided for each question.
5. Do not use correction fluid/tape or highlighters
6. The use of calculators is NOT allowed.

Questions 16 to 20 carry 1 mark each. Write your answers in the spaces provided. For questions which require units, give your answers in the units stated. (5 marks)

---

16. Write down all the common multiples of 3 and 4 that are smaller than 30.

Ans: \_\_\_\_\_

17. Find the value of  $0.45 \times 80$ .

Ans: \_\_\_\_\_

18. Huda had 1.05 ℓ of orange juice at first. She drank 480 ml of it. How many litres of orange juice was left?

Ans: \_\_\_\_\_ ℓ

19. Find the value of  $\frac{2}{3} \times \frac{4}{9}$

Ans: \_\_\_\_\_

20. In the figure, AFD and EFB are straight lines. Find  $\angle CFD$ .

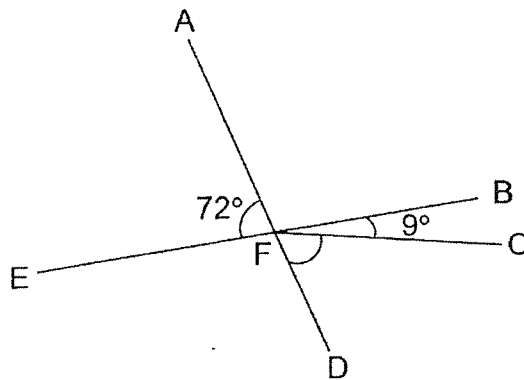

Ans: \_\_\_\_\_

Questions 21 to 30 carry 2 marks each. Show your working clearly and write your answers in the spaces provided. For questions that require units, give your answers in the units stated. (20 marks)

21. The line graph shows the number of bottles a machine filled over 12 minutes.

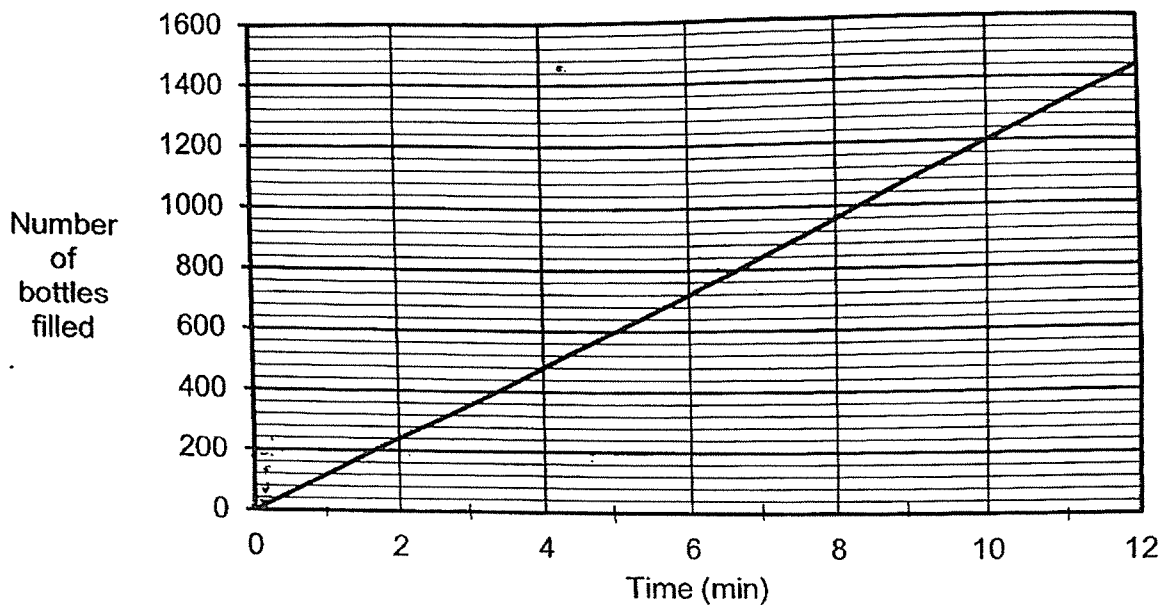

(a) How many bottles did the machine fill in two minutes?

Ans: (a) \_\_\_\_\_

(b) How long did it take for the machine to fill 960 bottles?

Ans: (b) \_\_\_\_\_ min

22. The Koh family watched a movie from 7.30 p.m. to 9.15 p.m. How much time did they spend watching the movie? Give your answer in h and min.

Ans: \_\_\_\_\_ h \_\_\_\_\_ min

23. (a) How many unit cubes are used to build solid A?

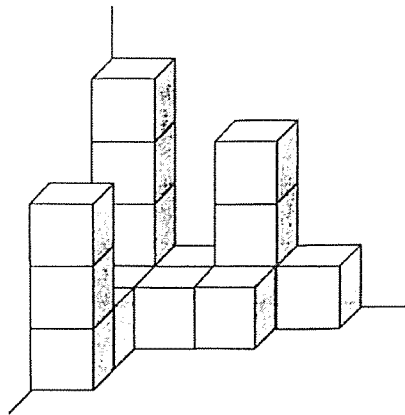

Solid A

Ans: (a) \_\_\_\_\_

(b) Draw the top view of solid B on the grid.

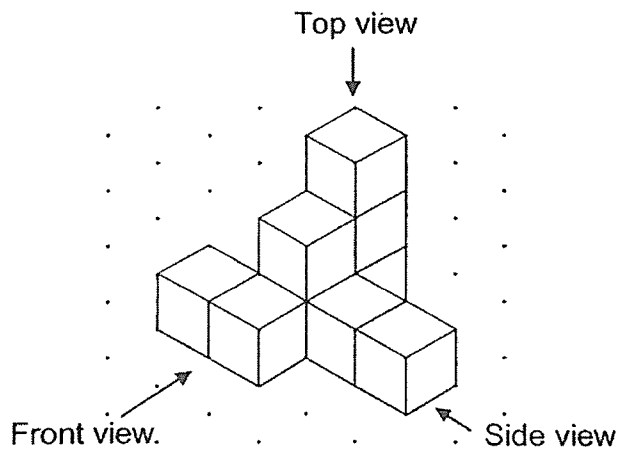

Solid B

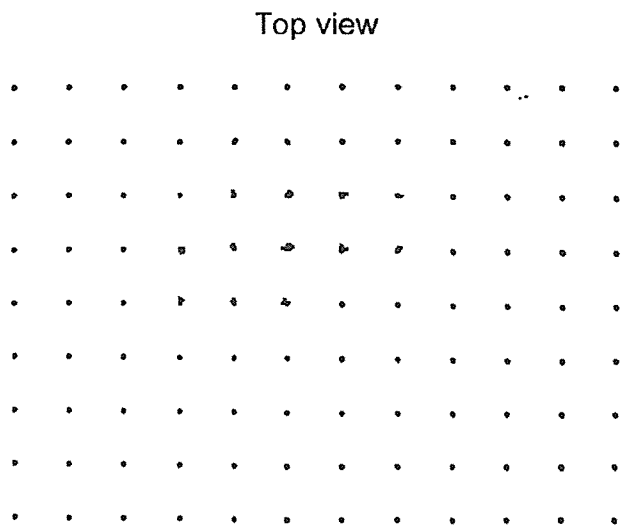

14. The table shows the number of hampers sold at a gift shop from Thursday to Saturday.

| Day      | Number of hampers sold |
|----------|------------------------|
| Thursday | 18                     |
| Friday   | 24                     |
| Saturday | 42                     |

- (a) Find the ratio of the number of hampers sold on Thursday to Friday to Saturday. Give your answer in the simplest form.

Ans: (a) \_\_\_\_\_

- (b) What was the average number of hampers sold over the three days?

Ans: (b) \_\_\_\_\_

25. There are 40 pupils in a class. 15% of them walk to school. How many pupils walk to school?

Ans: \_\_\_\_\_

26. Mr Tan had \$8000. He gave \$2000 to his wife and deposited the remaining amount in the bank. The bank paid 5% interest at the end of each year. How much money did he have in the bank at the end of 1 year?

Ans: \$ \_\_\_\_\_

27.

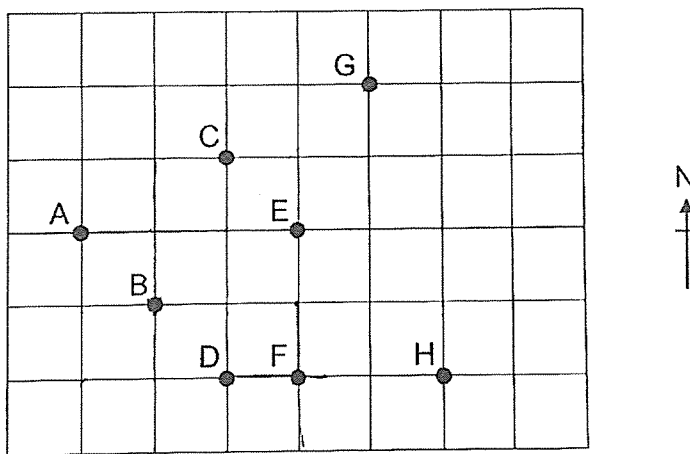

In the square grid,

- (a) point \_\_\_\_\_ is east of point F.

Ans: (a) \_\_\_\_\_

- (b) point B is south-west of point \_\_\_\_\_.

Ans: (b) \_\_\_\_\_

28. A painter mixed blue paint and yellow paint in the ratio of 3 : 7 to get green paint. He used 840 ml of yellow paint. How much blue paint did he use?

Ans: \_\_\_\_\_ ml

29. The table shows the charges for bicycle rental.

| Bicycle For Rent                                    |        |
|---|--------|
| First hour  | \$6.00 |
| Every additional $\frac{1}{2}$ hour or part thereof | \$2.50 |

John and his brother rented a bicycle each from 2.00 p.m. to 4.15 p.m. How much did they pay altogether?

Ans: \$ \_\_\_\_\_

30. PQRS is a trapezium and QR is parallel to PS.

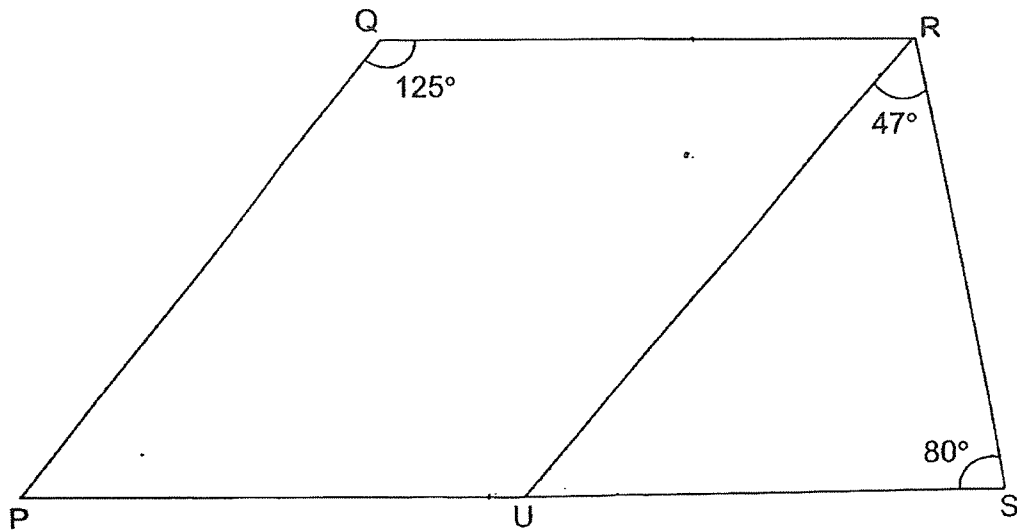

- (a) Find  $\angle QRU$ .

Ans: (a) \_\_\_\_\_ $^\circ$

- (b) Circle the words that describe PQRU correctly in the following statement:

PQRU ( is / is not ) a parallelogram because PQ ( is / is not ) parallel to UR.

End of Paper  
☺ Please check your work carefully ☺

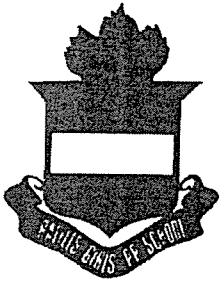

**RAFFLES GIRLS' PRIMARY SCHOOL  
END OF YEAR EXAMINATION  
PRIMARY FIVE  
2023  
MATHEMATICS  
PAPER 2**

Name: \_\_\_\_\_

Date : 24 October 2023

Class: P5 \_\_\_\_\_

Total Time : 1 hour 30 min

Math Teacher's name : \_\_\_\_\_

**INSTRUCTIONS TO CANDIDATES**

1. Do not turn over this page until you are told to do so.
2. Follow all instructions carefully.
3. Answer all questions.
4. Use a dark blue or black ballpoint pen to write your answers in the space provided for each question.
5. Do not use correction fluid/tape or highlighters.
6. The use of an approved calculator is allowed.

|      |    |
|------|----|
| Mark | 55 |
|------|----|

Questions 1 to 5 carry 2 marks each. Show your working clearly and write your answers in the spaces provided. For questions which require units, give your answers in the units stated. (10 marks)

---

1. The figure is made up of a rectangle and a triangle. The ratio of the area of the rectangle to the area of the triangle is 15 : 4. The area of the triangle is  $24 \text{ cm}^2$ . Find the area of the shaded part.

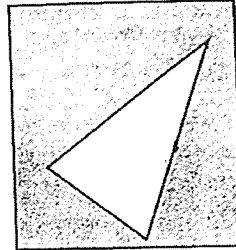

Ans: \_\_\_\_\_  $\text{cm}^2$

2. The table shows the number of buttons in a box. What percentage of the buttons in the box are red buttons? Round your answer to 2 decimal places.

| Colour | Number of buttons |
|--------|-------------------|
| Red    | 80                |
| Blue   | 130               |

Ans: \_\_\_\_\_ %

3. Printer A prints at a rate of 80 copies in 1 minute while Printer B prints at a rate of 300 copies in 5 minutes.

(a) Which printer prints at a faster rate?

Ans: (a) Printer \_\_\_\_\_

(b) By how many more copies does the faster printer print in one minute?

Ans: (b) \_\_\_\_\_ copies

4. Zhi Yu cycles 7 times a week. Each time, he cycles  $5\frac{4}{5}$  km from his home to the park and cycles home on the same route. What is the total distance that Zhi Yu cycles in a week? Express your answer as a mixed number in the simplest form.

Ans: \_\_\_\_\_ km

5. Shanti bought 1.3 kg of grapes. How much did she pay?

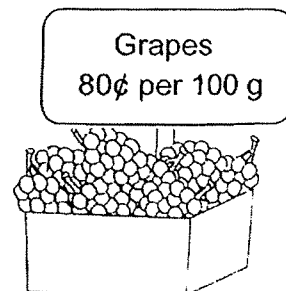

Ans : \$ \_\_\_\_\_

For questions 6 to 17, show your working clearly and write your answers in the spaces provided. The number of marks available is shown in brackets [ ] at the end of each question or part-question. (45 marks)

---

6. Mrs Lim paid \$53 for 5 mugs and 4 bowls. The cost of each bowl was \$2 more than the cost of each mug. How much did Mrs Lim pay for the 5 mugs?

Ans: \_\_\_\_\_ [3]

7. The line graph shows the total number of buns sold at a bakery from 09 00 to 16 00 on Monday. All the buns were sold out by 16 00.

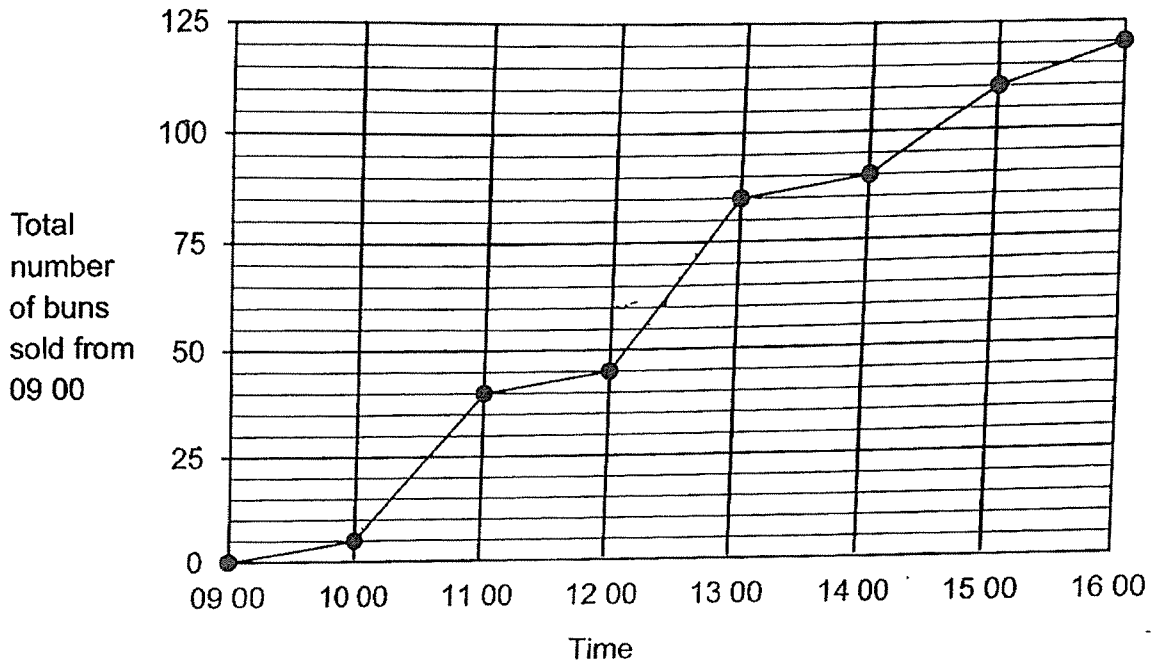

- (a) At what time did the bakery have 75% of its buns sold?

Ans: (a) \_\_\_\_\_ [2]

- (b) During which one-hour interval was the greatest number of buns sold?  
How many buns were sold during that one-hour interval?

Ans: (b) \_\_\_\_\_ to \_\_\_\_\_ [1]

\_\_\_\_\_ buns sold [1]

8. The graph shows the amount of money Belinda saved from January to June. Part of the graph is covered by an ink blot. The total amount of money saved from April to June is twice as much as the total amount of money saved from January to February.

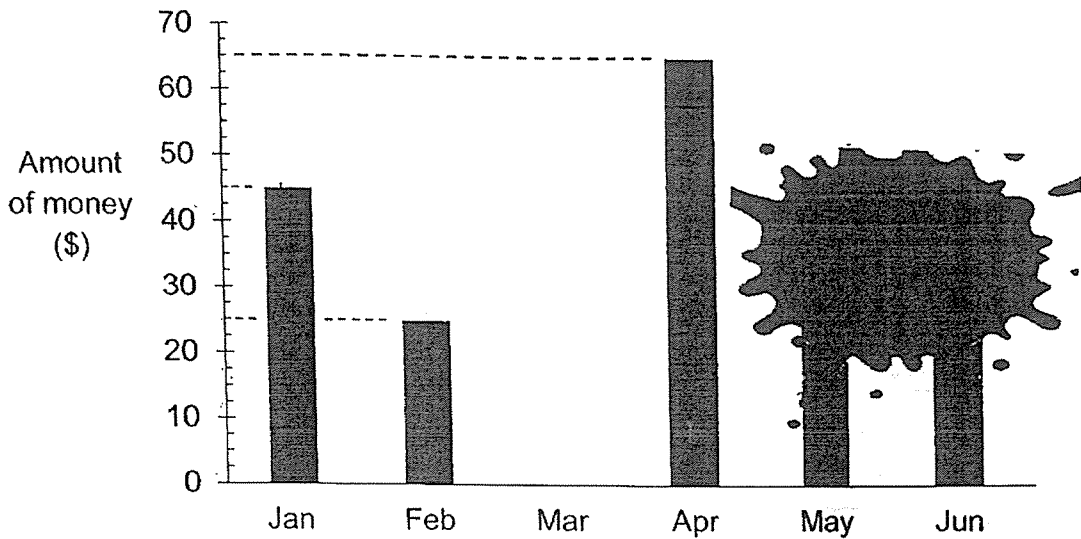

- (a) What was the average amount of money Belinda saved from January to April?

Ans: (a) \_\_\_\_\_ [2]

- (b) Each statement is either true, false or not possible to tell from the information given. Put a tick (✓) to indicate your answer.

| Statement   | True | False | Not possible to tell |
|---|------|-------|----------------------|
| Belinda saved the most amount of money in April.        |      |       |                      |
| Belinda saved \$140 from April to June.                 |      |       |                      |
| Belinda saved an equal amount of money in May and June. |      |       |                      |

[2]

9. Mrs Tan needed to prepare some drinks for her dinner party. She poured rose syrup into an empty rectangular container until it was  $\frac{1}{5}$  filled. Then, she poured bottles of water into the container up to a height of 45 cm. The volume of water in each bottle was 1.5 l.

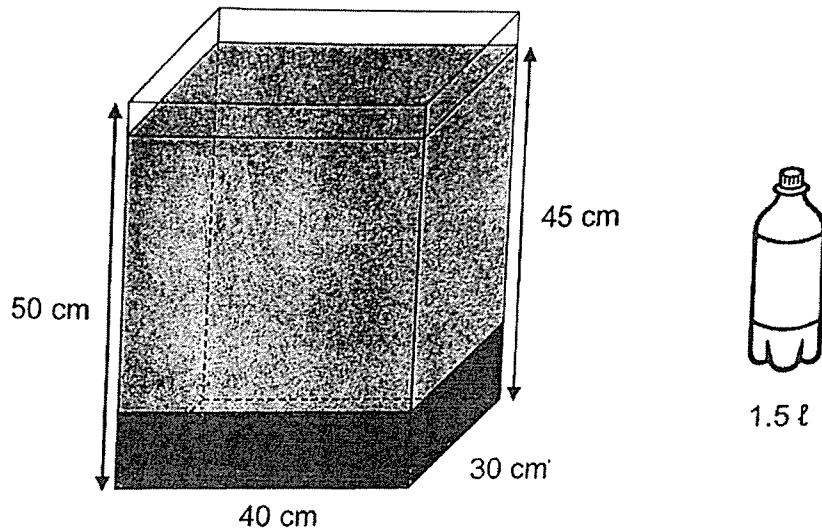

- (a) How much rose syrup was poured into the container?

Ans: (a) \_\_\_\_\_ [1]

- (b) How many bottles of water did Mrs Tan pour into the container?

Ans: (b) \_\_\_\_\_ [2]

10. Amira baked some cookies in the morning. She gave  $\frac{2}{7}$  of them to her neighbours and gave  $\frac{1}{2}$  of the remaining cookies to her friends.

In the afternoon, Amira baked another 85 cookies. The number of cookies that she had in the end was 13 more than what she baked in the morning.

- (a) What fraction of the cookies baked in the morning were given away?

Ans: (a) \_\_\_\_\_ [1]

- (b) How many cookies did Amira bake altogether on that day?

Ans: (b) \_\_\_\_\_ [3]

11. A box with 40 identical nails has a mass of 780 g. The same box with 30 identical batteries has a mass of 1.08 kg. The mass of each battery is twice the mass of each nail. Find the mass of the empty box in kilograms.

Ans: \_\_\_\_\_ [3]

12. Adam, Ben and Calvin had a total of 540 marbles. Adam gave  $\frac{1}{4}$  of his marbles to Ben. Then, Ben gave  $\frac{1}{3}$  of his total number of marbles to Calvin.

In the end, all the boys had the same number of marbles.

- (a) How many marbles did each boy have in the end?

Ans: (a) \_\_\_\_\_ [1]

- (b) How many marbles did Ben have at first?

Ans: (b) \_\_\_\_\_ [3]

13. Siew Li and Mariam each had a roll of ribbon of the same length for making bows. The same length of ribbon was used for each bow. Siew Li made 30 bows and had 1.5 m of ribbon left. Mariam made 10 bows and had 8.5 m of ribbon left. How many bows could each girl make at most with the ribbon that she had?

Ans: \_\_\_\_\_ [3]

14. The first five figures of a pattern are shown below.

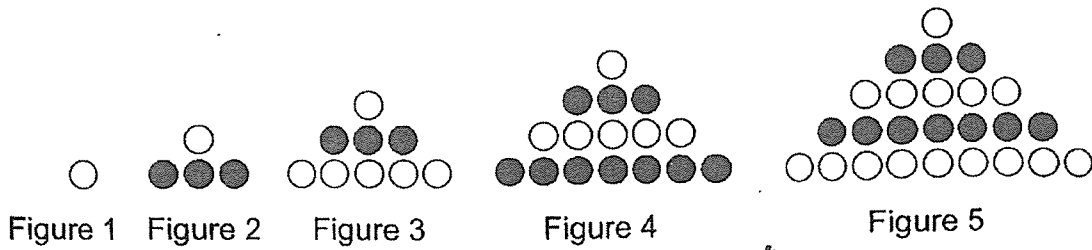

The table below shows the number of white and grey circles used for each figure.

| Figure Number                          | 1 | 2 | 3 | 4  | 5  | 6 |
|--|---|---|---|----|----|---|
| Number of white circles                | 1 | 1 | 6 | 6  | 15 |   |
| Number of grey circles                 | 0 | 3 | 3 | 10 | 10 |   |
| Total number of white and grey circles | 1 | 4 | 9 | 16 | 25 |   |

[1]

- (a) Fill in the table for Figure 6
- (b) What is the total number of white and grey circles in Figure 50?

Ans: (b) \_\_\_\_\_ [1]

- (c) In Figure 50, what fraction of the circles are grey? Give your answer in the simplest form.

Ans: (c) \_\_\_\_\_ [3]

15. A piece of paper in the shape of an equilateral triangle is folded along the dotted line as shown. Find  $\angle x$ .

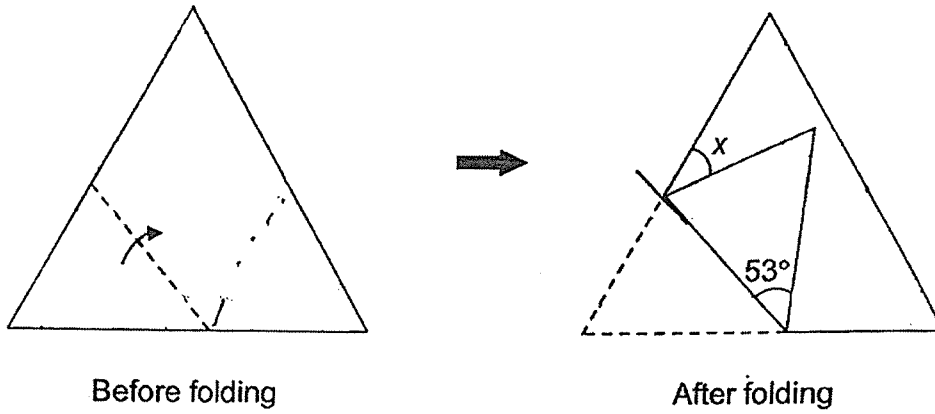

Ans: \_\_\_\_\_ [3]

16. The figure is made up of a square and a rectangle. The perimeter of Square ABCD is 72 cm longer than the perimeter of Rectangle DEFG.

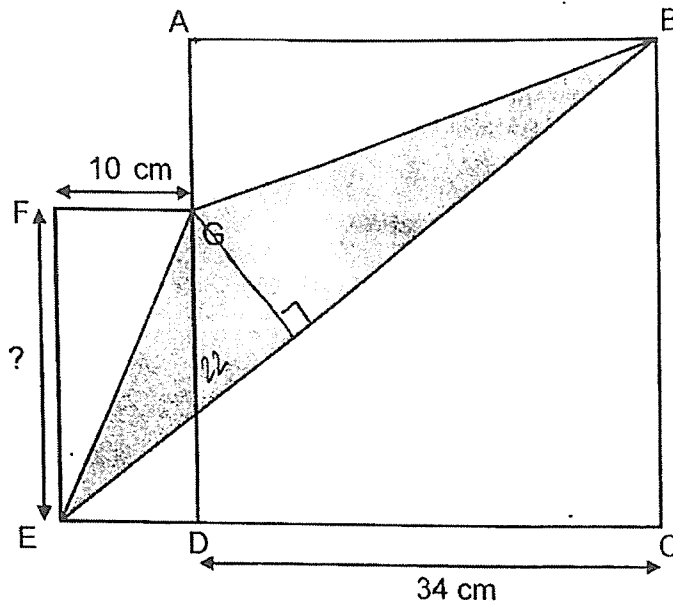

- (a) What is the length of FE?

Ans: (a) \_\_\_\_\_ [2]

- (b) What is the area of the shaded part?

Ans: (b) \_\_\_\_\_ [3]

17. ABCD is a rhombus and EBF is a straight line.

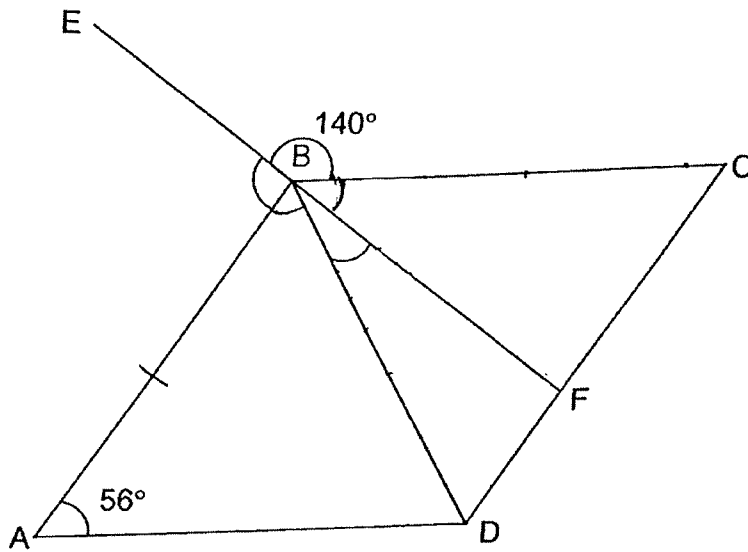

- (a) Find  $\angle ABE$ .

Ans: (a) \_\_\_\_\_ [2]

- (b) Find  $\angle DBF$ .

Ans: (b) \_\_\_\_\_ [2]

**End of Paper**  
☺ Please check your work carefully ☺

**SCHOOL :** RAFFLES GIRLS' PRIMARY SCHOOL  
**LEVEL :** PRIMARY 5  
**SUBJECT :** MATHEMATICS  
**TERM :** 2023 SA2

**PAPER 1 (BOOKLET A)**

|     |   |     |   |     |   |     |   |     |   |
|-----|---|-----|---|-----|---|-----|---|-----|---|
| Q1  | 4 | Q2  | 3 | Q3  | 3 | Q4  | 4 | Q5  | 2 |
| Q6  | 3 | Q7  | 1 | Q8  | 3 | Q9  | 3 | Q10 | 2 |
| Q11 | 2 | Q12 | 4 | Q13 | 1 | Q14 | 2 | Q15 | 2 |

**PAPER 1 (BOOKLET B)**

|      |                |
|------|----------------|
| Q16  | 12, 24         |
| Q17  | 36             |
| Q18  | 0.57 ℓ         |
| Q19  | $\frac{8}{27}$ |
| Q20  | 63°            |
| Q21a | 240            |
| Q21b | 8 min          |
| Q22  | 1 h 45 min     |
| Q23a | 16             |
| Q23b |                |
| Q24a | 3 : 4 : 7      |
| Q24b | 28             |
| Q25  | 6              |
| Q26  | 6300           |
| Q27a | H              |
| Q27b | G              |

|      |   |
|------|---|
| Q28  | 360 ml  |
| Q29  | \$27  |
| Q30a | 53°   |
| Q30b | PQRU is not a parallelogram because PQ is not parallel to UR. |

## PAPER 2

|      |  |
|------|--|
| Q1   | $4u = 24$<br>$1u = 6$<br>$11u = 11 \times 6 = 66\text{cm}^2$   |
| Q2   | $\frac{80}{210} \times 100\% = 38.10\%$  |
| Q3a  | A  |
| Q3b  | 20   |
| Q4   | $5\frac{4}{5} \times 7 \times 2 = 81\frac{1}{5} \text{ km}$  |
| Q5   | $1.3 \text{ kg} = 1300\text{g}$<br>$1300 \div 100 = 13$<br>$13 \times \$0.80 = \$10.40$  |
| Q6   | $4 \times \$2 = \$8$<br>$\$53 - 8 = \$45$<br>$\$45 \div 9 = \$5$<br>$\$5 \times 5 = \$25$  |
| Q7a  | 1400   |
| Q7b  | 1200 to 1300<br>40 buns sold   |
| Q8a  | $\$45 + \$25 + \$0 + \$65 = \$135$<br>$\$135 \div 4 = \$33.75$   |
| Q8b  | True, Ture, Not possible to tell   |
| Q9a  | $\frac{1}{5} \times 40 \times 30 \times 50 = 12000\text{ml} = 12\text{L}$  |
| Q9b  | $45 \times 40 \times 30 = 54000\text{ml}$<br>$54000 - 12000 = 42000\text{ml} = 42\text{L}$<br>$42 \div 1.5 = 28$                                 |
| Q10a | Total units for morning = 14u<br>Given to neighbours = 4u<br>Given to friends = $(14u - 4u) \div 2 = 5u$<br>Fraction given away = $\frac{9}{14}$ |

|      |  |
|------|--|
| Q10b | $85 - 13 = 72$<br>$72 \div 9 = 8$<br>$(14 \times 8) + 85 = \mathbf{197}$   |
| Q11  | $20u = 1.08 \text{ kg} - 0.78 \text{ kg} = 0.3 \text{ kg}$<br>$1u = 0.015 \text{ kg}$<br>$40u = 0.015 \text{ kg} \times 40 = 0.6 \text{ kg}$<br>$0.78 \text{ kg} - 0.6 \text{ kg} = \mathbf{0.18 \text{ kg}}$  |
| Q12a | $540 \div 3 = \mathbf{180}$  |
| Q12b | No. of marbles A gave to B = 60<br>No. of marbles B gave to C = 90<br>Marbles B had at first = $180 + 90 - 60 = \mathbf{210}$  |
| Q13  | Length of ribbon used for 20 bows = $8.5 \text{ m} - 1.5 \text{ m} = 7 \text{ m}$<br>Length of each bow = $7 \text{ m} \div 20 = 0.35 \text{ m}$<br>$1.50 \text{ m} \div 0.35 \text{ m} \approx 4.2$<br>$\quad \quad \quad = 4$<br>$30 + 4 = \mathbf{34}$  |
| Q14a | White circles = <b>15</b> , grey circles = <b>21</b> , total = <b>36</b>   |
| Q14b | $50 \times 50 = \mathbf{2500}$   |
| Q14c | Difference between grey and white circles = figure number<br>$2500 - 50 = 2450$<br>$2450 \div 2 = 1225$<br>$1225 + 50 = 1275$<br>$\begin{array}{r} 1275 \\ \underline{\quad} \\ 2500 \end{array} = \frac{51}{100}$   |
| Q15  | $180^\circ - 60^\circ - 53^\circ = 67^\circ$<br>$180^\circ - 67^\circ - 67^\circ = \mathbf{46^\circ}$  |
| Q16a | $136 - 72 = 64$<br>$64 - 10 - 10 = 44$<br>$44 \div 2 = \mathbf{22 \text{ cm}}$   |
| Q16b | Area of square = $34 \times 34 = 1156 \text{ cm}^2$<br>Area of rectangle = $22 \times 10 = 220 \text{ cm}^2$<br>Area of $\triangle EFG = 0.5 \times 22 \times 10 = 110 \text{ cm}^2$<br>Area of $\triangle ABG = 0.5 \times 12 \times 34 = 204 \text{ cm}^2$<br>Area of $\triangle BCE = 0.5 \times 44 \times 34 = 748 \text{ cm}^2$<br>Area of shaded part = $(1156 + 220) - (110 + 204 + 748) = \mathbf{314 \text{ cm}^2}$ |
| Q17a | $\angle ABC = 180^\circ - 56^\circ = 124^\circ$<br>$\angle ABE = 360^\circ - 140^\circ - 124^\circ = \mathbf{96^\circ}$  |
| Q17b | $\angle ABD = (180^\circ - 56^\circ) \div 2 = 62^\circ$<br>$\angle DBF = 180^\circ - 96^\circ - 62^\circ = \mathbf{22^\circ}$  |

