



Anglo-Chinese School
(Primary)

A Methodist Institution
(Founded 1896)

2023 END-OF-YEAR EXAMINATION
MATHEMATICS
PAPER 1 (BOOKLET A)
PRIMARY FIVE

Name: _____ () Class: Primary 5 _____

Date: 24 October 2023

Duration of Booklets A & B: 1 hour

INSTRUCTIONS TO CANDIDATES

1. This question paper consists of 8 printed pages, including the cover page.
2. Do not turn this page until you are told to do so.
3. Follow all instructions carefully.
4. Shade your answers on the Optical Answer Sheet (OAS) provided.
5. You are not allowed to use a calculator.

Questions 1 to 10 carry 1 mark each. Question 11 to 15 carry 2 marks each. For each question, four options are given. One of them is the correct answer. Make your choice (1, 2, 3 or 4) and shade your answer on the Optical Answer Sheet (20 marks)

1. Which one of the following is sixty-three thousand and forty in numerals?

- (1) 6340
- (2) 63 040
- (3) 63 400
- (4) 630 040

2. The figure below is made up of 20 identical small rectangles. What percentage of the figure is shaded?

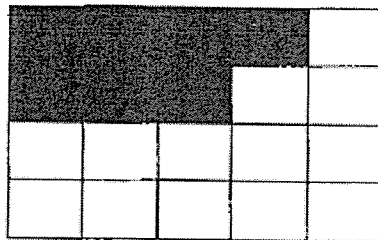

- (1) 35%
- (2) 20%
- (3) 3%
- (4) 7%

3. Which of the following is equal to $4\frac{5}{7}$?

(1) $\frac{20}{7}$

(2) $\frac{27}{7}$

(3) $\frac{33}{7}$

(4) $\frac{45}{7}$

4. Given that AD is the base of triangle ABD. Identify the height that is related to the base AD.

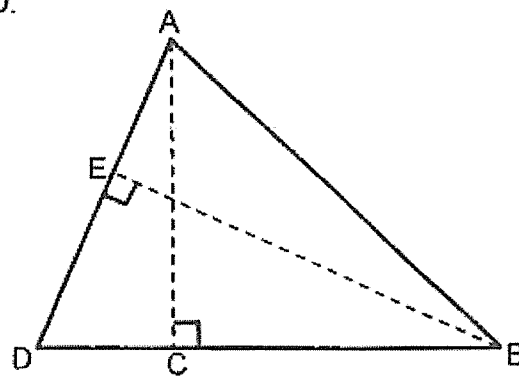

(1) AB

(2) AC

(3) BD

(4) BE

5. What is the value of the digit 5 in 50 146?

- (1) 50
- (2) 500
- (3) 5000
- (4) 50 000

6. Mrs Tan bought 4 kg of vegetables. She cooked $\frac{5}{8}$ of them.
How many kilograms of vegetables did she have left?

- (1) $1\frac{1}{2}$ kg
- (2) $2\frac{1}{2}$ kg
- (3) $3\frac{5}{8}$ kg
- (4) $4\frac{3}{8}$ kg

7. Which of the following numbers is the smallest?

- (1) 0.13
- (2) 0.31
- (3) 0.103
- (4) 0.301

8. In the figure below, AE, BF and CG are straight lines.
Which two angles are equal?

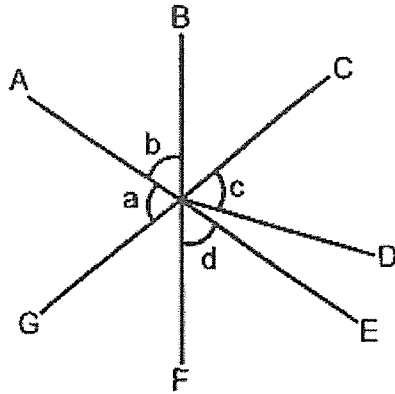

- (1) $\angle a$ and $\angle c$
 (2) $\angle a$ and $\angle d$
 (3) $\angle b$ and $\angle c$
 (4) $\angle b$ and $\angle d$
9. Find $\angle a$ in the figure shown below.

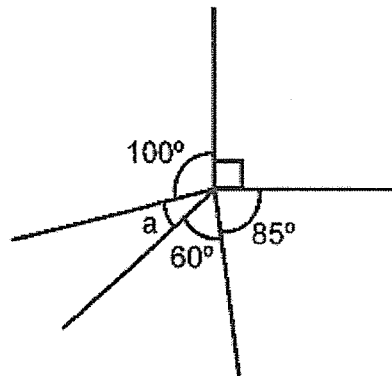

- (1) 20°
 (2) 25°
 (3) 30°
 (4) 35°

10. Tina drew a boat using circles, triangles and rectangles. What is the ratio of the number of circles to the total number of triangles and rectangles?
Give your answer in its simplest form.

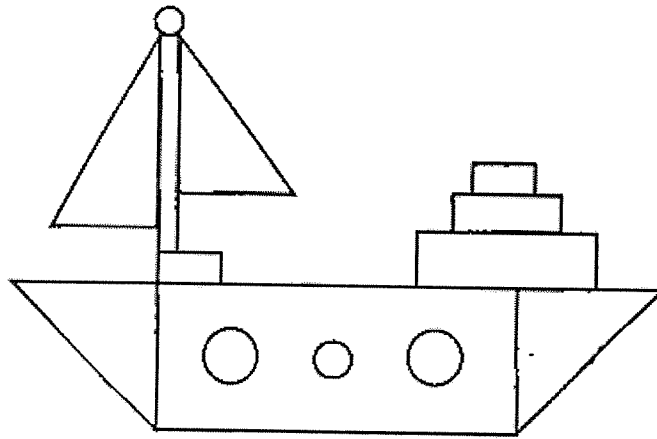

- (1) 1 : 1
(2) 2 : 3
(3) 2 : 5
(4) 5 : 2
11. A solid cuboid height 10 cm has a square base of side 2 cm. What is its volume?

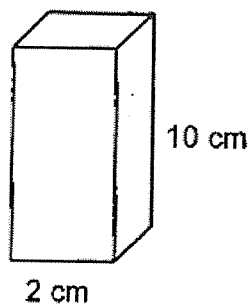

- (1) 20 cm^3
(2) 40 cm^3
(3) 120 cm^3
(4) 200 cm^3

12. The table shows the prices for a farm tour.

Quantity	Price
First 10 tickets	\$8 each
Every additional ticket	\$5

A group went for the farm tour and paid \$160. How many tickets did the group buy?

- (1) 16
(2) 20
(3) 26
(4) 32
13. In the figure below, ACD and BCE are straight lines. Find $\angle CDE$.

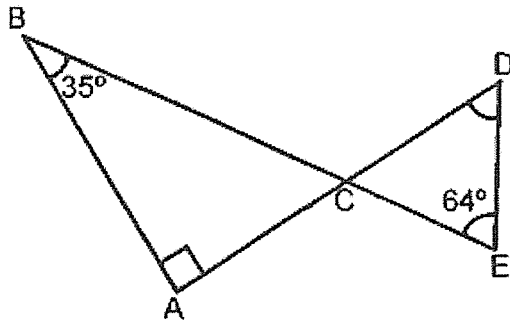

- (1) 61°
(2) 55°
(3) 29°
(4) 26°

14. Minyi received \$300 as a prize. He gave \$60 to his father. What percentage of the prize money did Minyi give to his father?

(1) 20%

(2) 40%

(3) 60%

(4) 80%

15. John had 30 more stamps than Peter at first. Peter gave 18 of his stamps to John. John now has 3 times as many stamps as Peter. How many stamps did Peter have at first?

(1) 42

(2) 51

(3) 72

(4) 81



Anglo-Chinese School
(Primary)

A Methodist Institution
(Founded 1886)

2023 END-OF-YEAR EXAMINATION
MATHEMATICS
PAPER 1 (BOOKLET B)
PRIMARY FIVE

Name: _____ () Class: Primary 5 ____

Date: 24 October 2023

Duration of Paper Booklets A & B: 1 hour

Parent's/Guardian's signature

INSTRUCTIONS TO CANDIDATES

1. This question paper consists of 9 printed pages, including the cover page.
2. Do not turn this page until you are told to do so.
3. Follow all instructions carefully.
4. Answer all questions.
5. Use a dark blue or black ballpoint pen to write your answers in the space provided for each question.
6. Do not use correction fluid/tape or highlighters.
5. You are not allowed to use a calculator.

Paper 1 Booklet A. Multiple-Choice Questions	20	
Paper 1 Booklet B. Short Answers: Part 1	5	
Paper 1 Booklet B. Short Answers: Part 2	20	
Total Marks	45	

Questions 16 to 20 carry 1 mark each. Write your answers in the spaces provided. For questions which require units, give your answers in the units stated. (5 marks)

16. Find the largest multiple of 7 that is smaller than 60.

Answer: _____

17. Round 33.652 to the nearest tenth.

Answer: _____

18. Find the value of $\frac{2}{9} \times \frac{3}{5}$.
Give your answer in its simplest form.

Answer: _____

19. A baker sells 65 slices of cakes per day. How many slices of cakes will the baker sell in a week?

Answer: _____

20. What is the value of $20 + (24 - 6) \div 6 \times 3$.

Answer: _____

Questions 21 to 30 carry 2 marks each. Show your working clearly and write your answers in the spaces provided. For questions which require units, give your answers in the units stated. (20 marks)

21. A machine takes 3 minutes to print 7 posters. At the same rate, how long will it take to print 42 posters?

Answer: _____ min

22. A piece of string is cut into three pieces in the ratio 2 : 4 : 7. The longest piece is 40 cm longer than the shortest piece. Find the original length of the piece of string.

Answer: _____ m

23. A box can hold either 12 big cubes or 48 small cubes. Keane put 6 big cubes and 7 small cubes in the box. How many more small cubes can Keane put into the box?

Answer: _____

24. In the figure below, ACD is an isosceles triangle and BCD is a straight line. $\angle ABC = 42^\circ$ and $\angle ADC = 70^\circ$. Find $\angle BAC$.

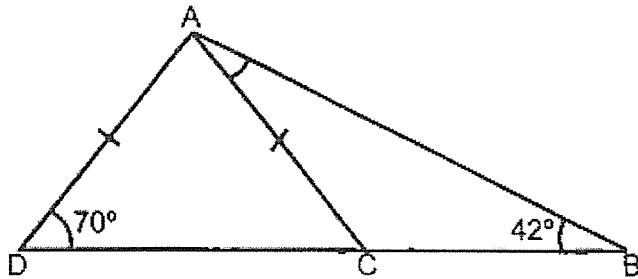

Answer: _____^o

25. Carol has \$215 more than Raju. Raju has \$35 less than Joel. Carol has \$148 more than the total amount of money Raju and Joel have. How much money does Raju have?

Answer: \$ _____

26. The table below shows the number of pages of a book Anna read from Monday to Friday.

Day	Mon	Tue	Wed	Thu	Fri
Number of pages	6	5	8	7	?

Anna read an average of 8 pages from Monday to Friday. How many pages did she read on Friday?

Answer: _____

27. In the figure below, ACDE is a parallelogram. $\angle AEB = 36^\circ$ and $\angle CBE = 157^\circ$. Find $\angle BCD$.

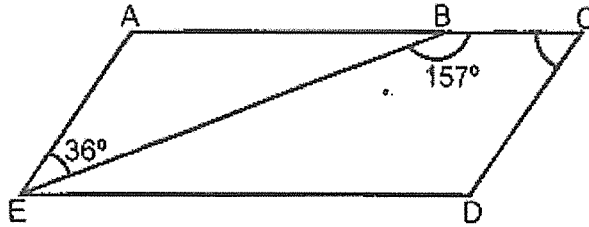

Answer: _____^o

28. Annie, Ben and Caili shared some money. The ratio of Annie's money to Ben's money was 4 : 1. Caili received \$84 and she had \$24 more than Annie. How much money did Ben receive?

Answer: \$ _____

29. In the figure below, ABD is an equilateral triangle and $ABCE$ is a trapezium. CDE is a straight line and $\angle DAE = 49^\circ$. Find $\angle CBD$.

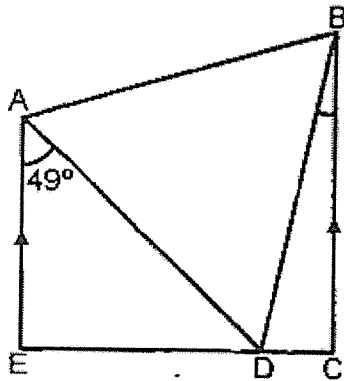

Answer: _____^o

30. A triangular piece of paper is folded at one corner to form 3 smaller identical triangles as shown below. Find the area of the triangular piece of paper before it was folded?

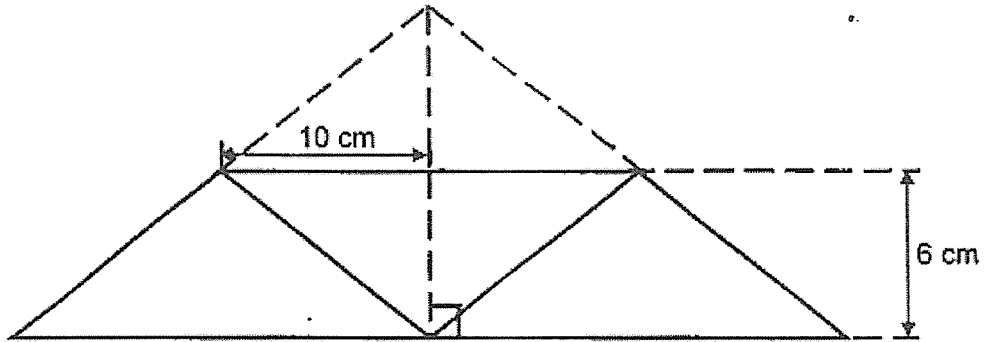

Answer: _____ cm^2

End of Paper 1



**Anglo-Chinese School
(Primary)**

A Methodist Institution
(Founded 1886)

**2023 END-OF-YEAR EXAMINATION
MATHEMATICS
PAPER 2
PRIMARY FIVE**

Name: _____ () Class: Primary 5 _____

Date: 24 October 2023

Duration of Paper 2: 1 hour 30 minutes

Parent's Guardian's signature

INSTRUCTIONS TO CANDIDATES

1. This question paper consists of 16 printed pages, including the cover page.
2. Do not turn this page until you are told to do so.
3. Follow all instructions carefully.
4. Answer all questions.
5. Use a dark blue or black ballpoint pen to write your answers in the space provided for each question.
6. Do not use correction fluid/tape or highlighters.
7. You are allowed to use a calculator.

Paper 2 Section A. Short Answers	10	
Paper 2 Section B. Problem Sums	45	
Total Marks	55	

Questions 1 to 5 carry 2 marks each. Show your working clearly and write your answers in the space provided. For questions which require units, give your answers in the units provided. (10 marks)

1. 7500 ml of water was poured into 6 containers equally.
How many litres of water were there in one container?

Answer: _____ l

2. There are less than 40 apples in a box. Adam, Chloe and Eddy shared the box of apples in the ratio 3 : 1 : 5.

Each statement below is either true, false or not possible to tell from the information given. For each statement, put a tick (\checkmark) to indicate your answer.

Statement	True	False	Not possible to tell
There are 9 apples in the box.			
Adam received 10 more apples than Chloe.			

3. The solid below is made up of 1-cm cubes.

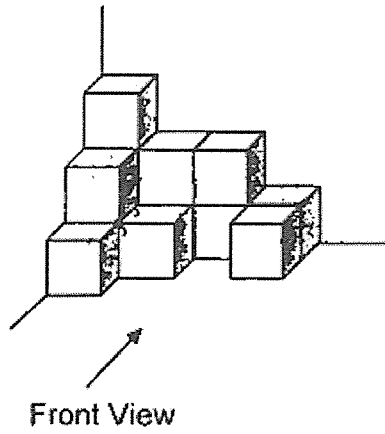

(a) What is the volume of the solid?

Answer: (a) _____ cm^3

(b) Draw the front view of the solid on the square grid below.

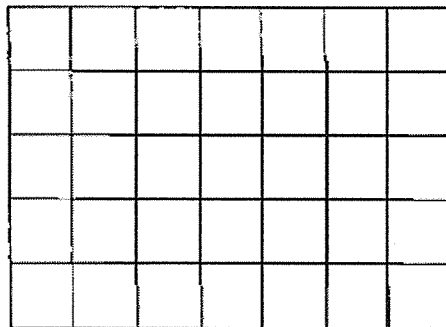

4. The table shows the postage rates for sending mails in Singapore.

Mass step not over	Small envelope	Large envelope
20 g	\$0.31	\$0.60
40 g	\$0.38	\$0.60
100 g		\$0.60
250 g		\$0.90
500 g		\$1.15

Mr Cheng sent a small envelope with a mass of 30 g and a large envelope with a mass of 400 g. How much postage did Mr Cheng pay altogether?

Answer: \$ _____

5. Siti spent $\frac{1}{3}$ of her money on a dress and $\frac{1}{5}$ of her money on a handbag. She had \$168 left. How much money did she spend on her handbag?

Answer: \$ _____

For questions 6 to 17, show your steps clearly in the space provided for each question and write your answers in the spaces provided.
For questions which require units, give your answers in the units stated.
The number of marks available is shown in brackets [] at the end of each question or part-question. (45 marks)

6. In the figure below, ABCE is a rhombus and CDE is a right-angled triangle.
 $\angle ABC = 56^\circ$ and $\angle AED = 97^\circ$. Find $\angle CDE$.

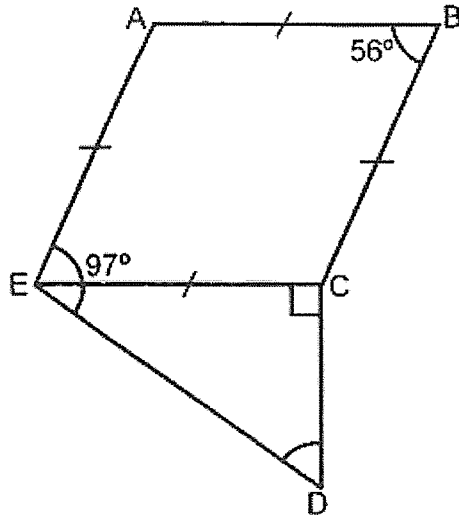

Answer: _____ [3]

7. There are some paper clips in a box. $\frac{4}{5}$ of them are blue. $\frac{3}{4}$ of the remaining paper clips are red and the rest are yellow. There are 48 red paper clips. How many paper clips are there in the box?

Answer: _____ [3]

8. There was a total of 185 mugs and cups in a shop. There were 4 times as many mugs as cups. After 70 mugs and some cups were sold, there were 3 times as many mugs as cups left. How many cups were left?

Answer: _____ [3]

9. The figure below is made up of square ABDE and triangle CDE. The area of square ABDE is 64 cm^2 and the height of triangle CDE is 20 cm . Find the area of the shaded triangle CBD.

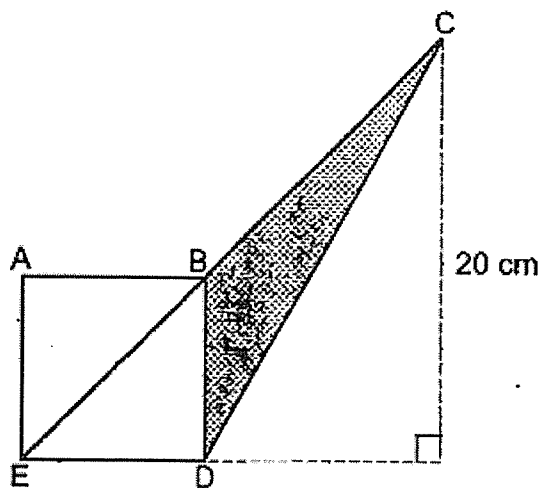

Answer: _____ [3]

10. The line graph shows the number of visitors at a science exhibition from January to June.

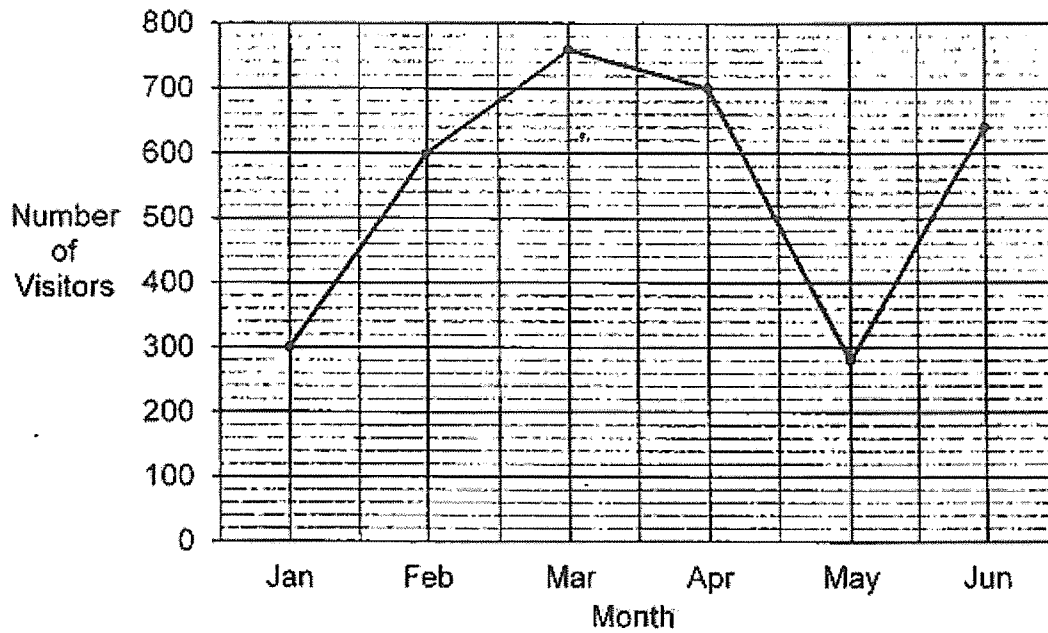

- (a) During which one-month period did the number of visitors increase the most?
- (b) Each visitor paid \$6.50 for a ticket to the exhibition. How much money was collected from the sales of the total number of tickets from January to April?

Answer: (a) _____ to _____ [1]

(b) _____ [2]

11. In a race, there were 1050 participants altogether. 70% of the participants were men and the rest were women. 80% of the women and some men finished the race. A total of 230 participants did not finish the race.
- (a) How many women joined the race?
 - (b) How many men finished the race?

Answer: (a)_____ [1]

(b)_____ [3]

12. Alice has some paperclips. If she gives each friend 14 paperclips, she will have 4 paperclips left. If she gives each of them 20 paperclips, she will be short of 68 paperclips.
- (a) How many friends did Alice have?
 - (b) How many paperclips did Alice have?

Answer: (a) _____ [2]

(b) _____ [2]

13. Alex, Ben and Charles shared some stickers. Ben received 3 times as many stickers as Charles. The number of stickers Alex received was $\frac{3}{5}$ the total number of stickers. Alex received 120 more stickers than Charles.
- (a) What fraction of the stickers did Charles have?
- (b) How many stickers did the boys have altogether?

Answer: (a) _____ [1]

(b) _____ [3]

14. Simon bought an equal number of sandwiches and pies. A sandwich cost \$4 and a pie cost \$1.80 less than a sandwich. He paid a total of \$279. How much did Simon pay for the pies?

Answer: _____ [4]

15. Container A measuring 30 cm by 16 cm by 15 cm was completely filled with water at first. Container B is a cubical tank of edge 10 cm. Ravi poured some of the water from Container A into Container B to fill it completely.

- (a) How much water was left in Container A?
(b) After Ravi used some water to water his plants, he had 5150 ml of water left. How much water did Ravi use to water his plants?

Give your answer in litres.

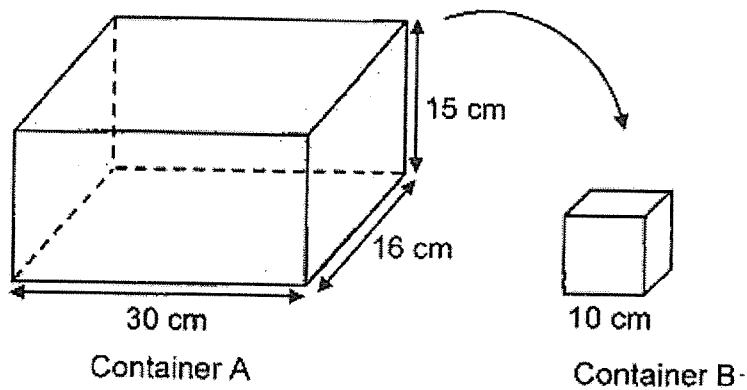

Answer: (a) _____ [2]

(b) _____ [2]

16. The bar graph below shows the number of cupcakes sold from Monday to Friday.

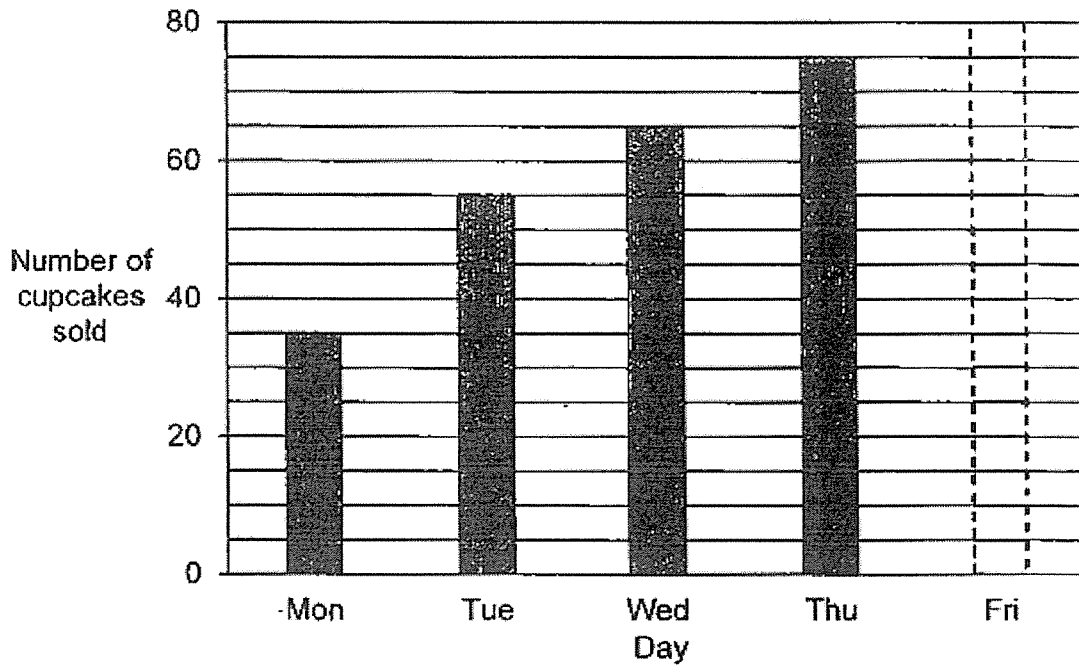

- (a) What was the average number of cupcakes sold on Monday and Tuesday?
- (b) Find the total number of cupcakes sold from Monday to Thursday.
- (c) The average number of cupcakes sold for the 5 days was 56. Find the number of cupcakes sold on Friday. Shade your answer in the graph above. [2]

Answer: (a) _____ [2]

(b) _____ [1]

17. The pattern below is made up of squares and dots. Study the pattern carefully and answer the following questions.



Figure 1

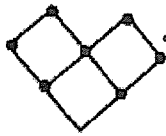

Figure 2

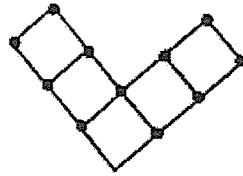

Figure 3

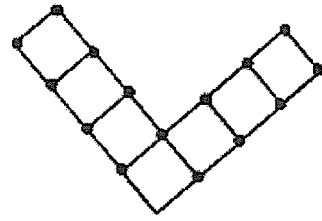

Figure 4

- (a) Complete the table below by filling in the number of dots in Figure 5.

Figure	1	2	3	4	5
Number of squares	1	3	5	7	9
Number of dots	3	7	11	15	

[1]

- (b) How many squares are there in Figure 12?
 (c) In which figure are there 295 dots?

Answer: (b) _____ [2]

(c) _____ [2]

End of Paper 2

SCHOOL : ACS PRIMARY SCHOOL
LEVEL : PRIMARY 5
SUBJECT : MATHEMATICS
TERM : 2023 SA2

PAPER 1 (BOOKLET A)

Q1	2	Q2	1	Q3	3	Q4	4	Q5	4
Q6	1	Q7	3	Q8	4	Q9	2	Q10	3
Q11	2	Q12	3	Q13	1	Q14	1	Q15	2

PAPER 1 (BOOKLET B)

Q16	56
Q17	33.7
Q18	$\frac{2}{15}$
Q19	455
Q20	29
Q21	18 min
Q22	1.04 m
Q23	17
Q24	28°
Q25	\$32
Q26	14
Q27	59°
Q28	\$15
Q29	11°
Q30	240 cm ²

PAPER 2

Q1	7500 ml ÷ 6 = 1250 ml = 1.25 ℓ
Q2	Not possible to tell; False

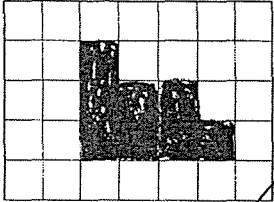
Q3a	13 cm³
Q3b	
Q4	$\$0.38 + \$1.15 = \mathbf{\$1.53}$
Q5	<p>Make fractions into one common denominator: $\frac{1}{3} = \frac{5}{15}, \frac{1}{5} = \frac{3}{15}$</p> <p>Total 15u, spent 8u, left 7u 7u = \$168 1u = \$24 3u = \$72</p>
Q6	$\angle CED = 97^\circ - 56^\circ = 41^\circ$ $\angle CDE = 180^\circ - 41^\circ - 90^\circ = \mathbf{49^\circ}$
Q7	$48 \div 3 = 16$ $16 \times 4 = 64$ $64 \times 5 = \mathbf{320}$
Q8	$185 \div 5 = 37$ $37 \times 4 = 148$ $148 - 70 = 78$ $78 \div 3 = \mathbf{26}$
Q9	$\sqrt{64} = 8 \text{ cm}$ Area of $\triangle CED = \frac{1}{2} \times 8 \times 20 = 80 \text{ cm}^2$ Area of $\triangle BED = 32 \text{ cm}^2$ Shaded $\triangle = 80 - 32 = \mathbf{48 \text{ cm}^2}$
Q10a	May to June
Q10b	Total visitors = $300 + 600 + 760 + 700 = 2360$ Total sales = $2360 \times \$6.50 = \mathbf{\$15340}$
Q11a	$10u = 1050$ $1u = 105$ $3u = \mathbf{315}$
Q11b	No. of women who did not finish race = $0.2 \times 315 = 63$ No. of men who did not finish race = $230 - 63 = 167$ No. of men who finished race = $(1050 - 315) - 167 = \mathbf{568}$

Q12a	Multiples of 14	84	98	112	126	140	154	168
	Paperclips	88	102	116	130	144	158	<u>172</u>
	Multiples of 20	120	140	160	180	200	220	240
	Paperclips	52	72	92	112	132	152	<u>172</u>
	$168 \div 14 = 12$							
Q12b	172							
Q13a	Alex: 6u, Ben: 3u, Charles: 1u Fraction Charles has = $\frac{1}{10}$							
Q13b	$6u - 1u = 120$ $5u = 120$ $1u = 24$ $10u = \mathbf{240}$							
Q14	Grouping method: group 1 sandwich and 1 pie together Cost of pie = $\$4 - \$1.80 = \$2.20$ Cost of 1 group = $\$4 + \$2.20 = \$6.20$ No. of groups = $\$279 \div \$6.20 = 45$ Total paid for pies = $45 \times \$2.20 = \mathbf{\$99}$							
Q15a	Vol. of container A = $30 \times 15 \times 16 = 7200$ ml Vol. of container B = $10 \times 10 \times 10 = 1000$ ml Amt. of water left = $7200 - 1000 = \mathbf{6200}$ ml							
Q15b	Water used = $6200 - 5150 = 1050$ ml = 1.05 l							
Q16a	Average = $(35 + 55) \div 2 = \mathbf{45}$							
Q16b	Total = $35 + 55 + 65 + 75 = \mathbf{230}$							
Q16c								
Q17a	19							
Q17b	$12 - 1 = 11$ $11 \times 2 = 22$ $22 + 1 = \mathbf{23}$							
Q17c	$295 - 3 = 292$ $292 \div 4 = 73$ $73 + 1 = \mathbf{74}$							

