



RED SWASTIKA SCHOOL

2023 END OF YEAR EXAMINATION

MATHEMATICS

Name : _____ ()

Class : Primary 4 / _____

Date : 31 OCT 2023

BOOKLET A

20 Questions

40 Marks

Duration of Paper : 1 hour 45 minutes

Note:

1. Do not open this Booklet until you are told to do so.
2. Read carefully the instructions given at the beginning of each part of the Booklet.
3. Do not waste time. If a question is difficult for you, go on to the next one.
4. Check your answers thoroughly and make sure you attempt every question.
5. In this booklet, you should have the following:
 - (a) Page 1 to Page 7
 - (b) Questions 1 to 20

Questions 1 to 20 carry 2 marks each. For each question, four options are given. One of them is the correct answer. Make your choice (1, 2, 3 or 4). Shade the correct oval (1, 2, 3 or 4) on the Optical Answer Sheet.

(40 marks)

-
- 1 The value of the digit 4 in 54 397 is _____.
- (1) 40
(2) 400
(3) 4000
(4) 40 000
- 2 22 758 rounded to the nearest hundred is _____.
- (1) 22 700
(2) 22 760
(3) 22 800
(4) 23 000
- 3 How many one-sevenths are there in 2 wholes?
- (1) $\frac{2}{7}$
(2) $3\frac{1}{2}$
(3) 7
(4) 14
- 4 Arrange the following fractions from the greatest to the smallest.

$$\frac{1}{3}, \quad \frac{5}{6}, \quad \frac{7}{12}$$

- | | (greatest) | | (smallest) |
|-----|------------------|------------------|----------------|
| (1) | $\frac{5}{6}$, | $\frac{1}{3}$, | $\frac{7}{12}$ |
| (2) | $\frac{7}{12}$, | $\frac{5}{6}$, | $\frac{1}{3}$ |
| (3) | $\frac{5}{6}$, | $\frac{7}{12}$, | $\frac{1}{3}$ |
| (4) | $\frac{1}{3}$, | $\frac{5}{6}$, | $\frac{7}{12}$ |

5 In the number 32.14, the digit _____ is in the tenths place.

- (1) 1
- (2) 2
- (3) 3
- (4) 4

6 In the figure below, which angle is smaller than a right angle?

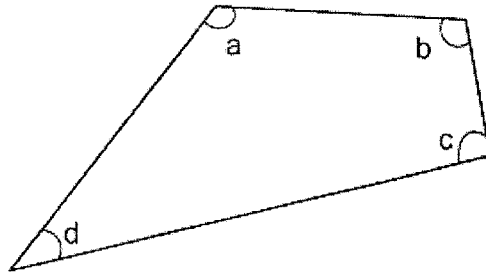

- (1) $\angle a$
- (2) $\angle b$
- (3) $\angle c$
- (4) $\angle d$

7 In the square grid below, which of the following lines is parallel to NQ?

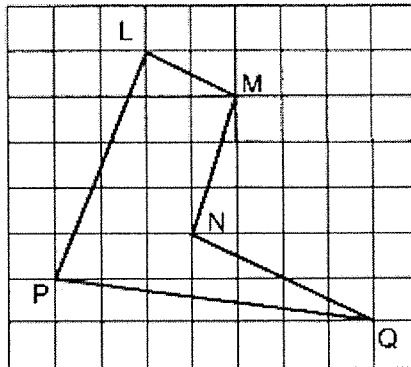

- (1) LM
- (2) LP
- (3) MN
- (4) QP

- 8 Which of the following could be the height of the study table?

- (1) 7 m
- (2) 70 m
- (3) 7 cm
- (4) 70 cm

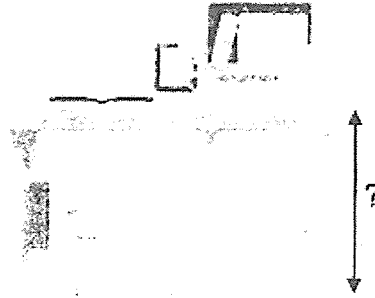

- 9 A fruit seller had 3200 oranges. 310 oranges were rotten. He threw the rotten oranges away and packed the rest equally into 5 boxes. How many oranges were there in each box?

- (1) 330
- (2) 578
- (3) 640
- (4) 702

- 10 The mass of one parcel is 8.32 kg. Find the mass of 8 such parcels.

- (1) 1.04 kg
- (2) 16.32 kg
- (3) 64.46 kg
- (4) 66.56 kg

- 11 In the number line, what is the value represented by A?

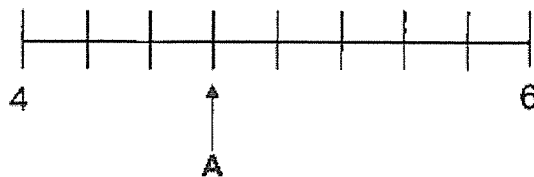

- (1) 4.30
- (2) 4.60
- (3) 4.75
- (4) 5.25

- 12 Jane started doing her homework at the time shown below. She took 45 min to do her homework. What time did she complete her homework?

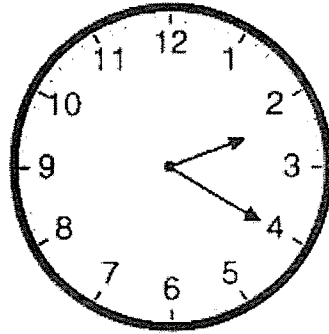

- (1) 1.35 p.m.
(2) 3.05 p.m.
(3) 3.25 p.m.
(4) 4.55 p.m.
- 13 Kenneth wanted to buy two shirts that cost \$25.65 each, but he was short of \$14.20. How much money did Kenneth have?
- (1) \$11.45
(2) \$37.10
(3) \$39.85
(4) \$65.50
- 14 After donating $\frac{1}{3}$ of her money to charity, Janelle had \$24 left. How much money did she have at first?
- (1) \$8
(2) \$16
(3) \$27
(4) \$36

- 15 The figure is made up of 2 identical rectangles.
What is the perimeter of the figure?

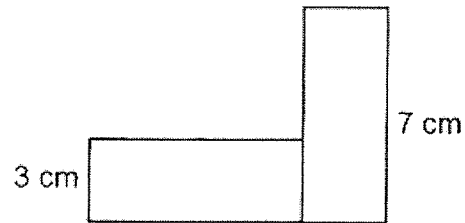

- (1) 30 cm
(2) 34 cm
(3) 37 cm
(4) 40 cm
- 16 The figure below is made up of a rectangle measuring 20 cm by 10 cm with a shaded rectangle placed inside. Find the area of the shaded rectangle.

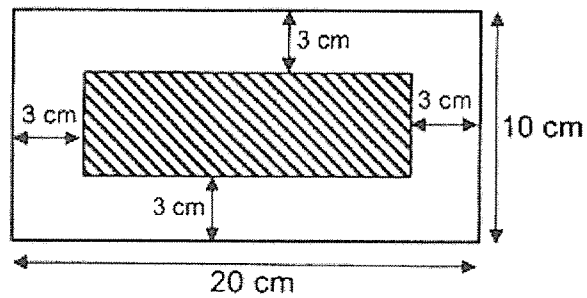

- (1) 56 cm^2
(2) 68 cm^2
(3) 98 cm^2
(4) 119 cm^2

Use the following diagram to answer Question 17.

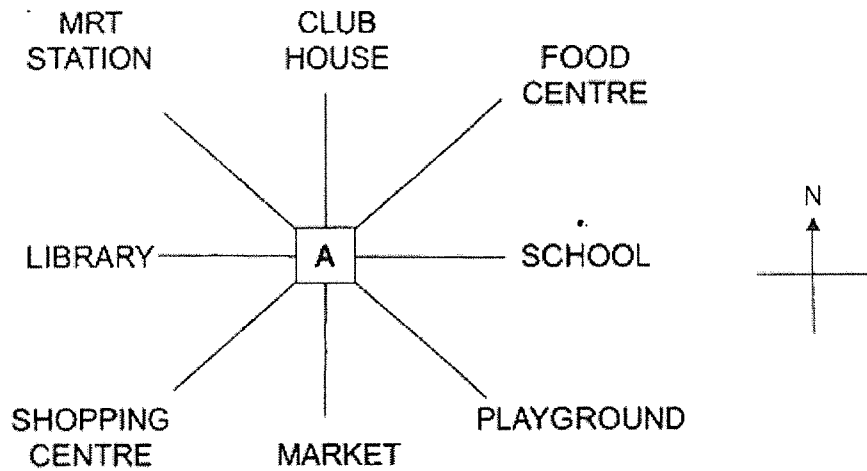

17 Yanda is standing at the point marked A in the diagram above. He is facing the market. Where will he be facing when he turns 135° clockwise?

- (1) Food Centre
- (2) Playground
- (3) Shopping Centre
- (4) MRT Station

The table below shows the number of students who borrowed books from the school library.

Number of books borrowed	1	2	3	4	5
Number of students	50	125	275	155	30

18 How many students borrowed more than 3 books?

- (1) 185
- (2) 275
- (3) 450
- (4) 460

The line graph below shows the number of fruits sold in a fruit store from Monday to Friday.

Use the information in the graph to answer Question 19.

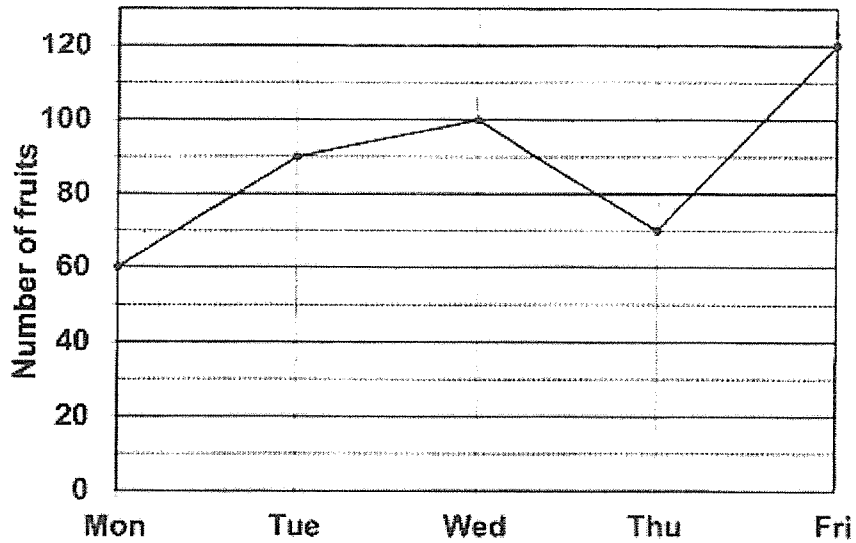

- 19 How many more fruits were sold on Friday than Tuesday?
- (1) 30
 - (2) 90
 - (3) 120
 - (4) 210
- 20 Ben is 8 years old. Charles is three times as old as Ben and 4 years older than Daniel. How old is Ben when Daniel is 50 years old?
- (1) 28
 - (2) 30
 - (3) 38
 - (4) 46
-



RED SWASTIKA SCHOOL
2023 END OF YEAR EXAMINATION
MATHEMATICS

Name : _____ ()

Class : Primary 4 / _____

Date : 31 OCT 2023

BOOKLET B

25 Questions
60 Marks

In this booklet, you should have the following:
(a) Page 8 to Page 20
(b) Questions 21 to 45

MARKS

	OBTAINED	POSSIBLE
BOOKLET A		40
BOOKLET B		60
TOTAL		100

Parent's Signature : _____

Questions 21 to 40 carry 2 marks each. Show your working clearly in the space below each question and write your answers in the spaces provided. For questions which require units, give your answers in the units stated.

(40 marks)

21 Arrange the following numbers from the greatest to the smallest.

379, 937, 973, 397

Ans: _____ , _____ , _____ , _____
(greatest) (smallest)

22 Find the product of 4290 and 3

Ans: _____

23 Write $\frac{23}{6}$ as a mixed number.

Ans: _____

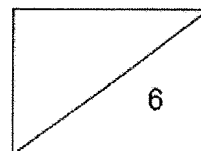

24 Find the value of $1 - \frac{1}{6} - \frac{1}{3}$

Ans: _____

25 Round off 12.56 to the nearest whole number.

Ans: _____

26 Find the value of 6.35×8

Ans: _____

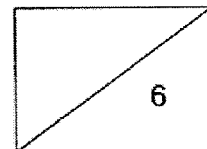

27 In the figure below, ABCD is a rectangle. Find $\angle x$.

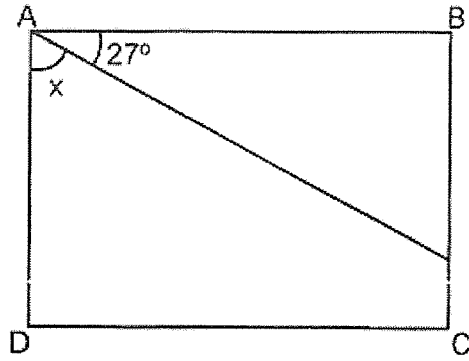

Ans: _____°

28 Write the decimal represented by A.

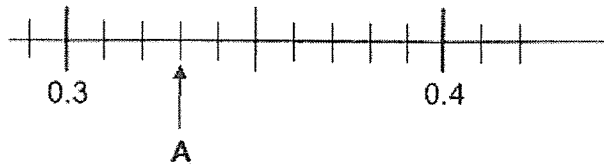

Ans: _____

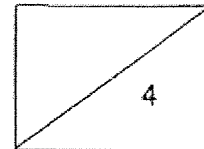

- 29 Some factors of 32 are 1, 2, 4 and 32. What are the other two factors of 32?

Ans: _____ and _____

- 30 A number when divided by 7 gives a quotient of 145 and a remainder of 6. What is the number?

Ans: _____

- 31 The total marks that John and Ken scored in a Science test was 175. John scored 23 more marks than Ken. How many marks did Ken score in the Science test?

Ans: _____

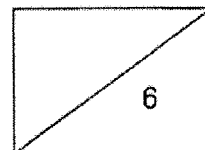

- 32 Derek baked some cookies. The number of cookies he baked was fewer than 30. He could pack them equally into bags of 3 cookies or bags of 4 cookies with no leftovers. What was the greatest possible number of cookies he baked?

Ans: _____

- 33 Tank A contained 5 times as much water as Tank B at first. After 20.16 ℓ of water from Tank A was poured into Tank B, both tanks contained an equal amount of water. How much water was there in Tank A at first?

Ans: _____ ℓ

- 34 Rosalind had a piece of copper wire. She bent the copper wire into the shape shown in the figure below which is made up of 3 squares. The length XY is 9 cm. Find the length of the copper wire used.

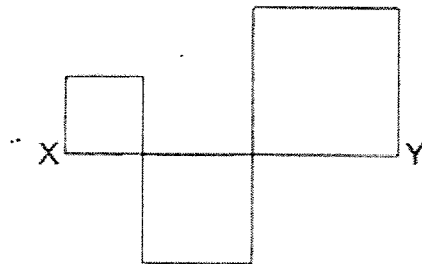

Ans: _____ cm

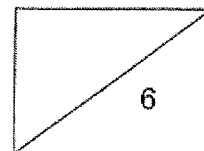

- 35 Mr Fariz folded a rectangular piece of paper to form the figure shown below. Find the area of the rectangular piece of paper.

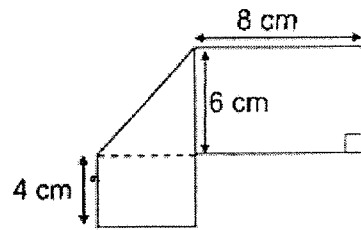

Ans: _____ cm^2

- 36 Complete the symmetric figure using Line AB as the line of symmetry.

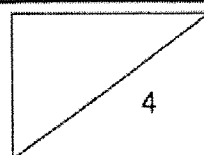
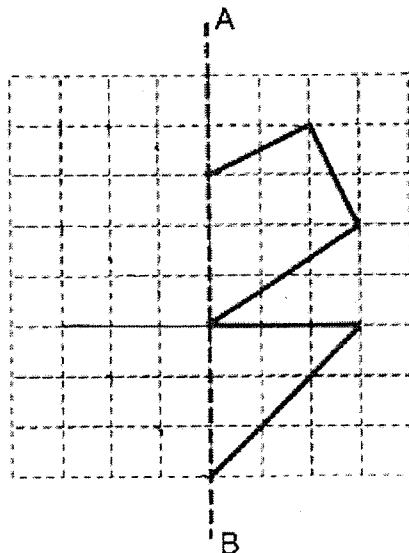

The bar graph below shows the number of students in each group. The number of students is not shown on the scale. Study the graph carefully and use it to answer Questions 37 to 38.

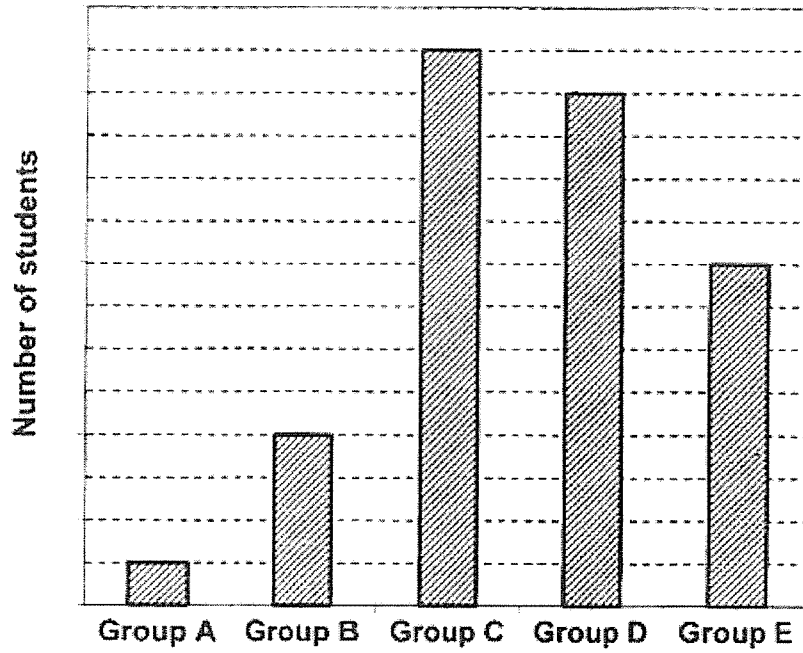

37 Which group has twice the number of students as Group B?

Ans: Group _____

38 Group C has 5 more students than Group D. How many students are there in Group B?

Ans: _____

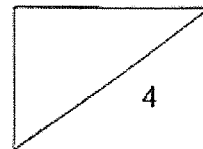

- 39 Two rods of the same length are placed as shown.
There is an overlap of 6 cm. What is the length of each rod?

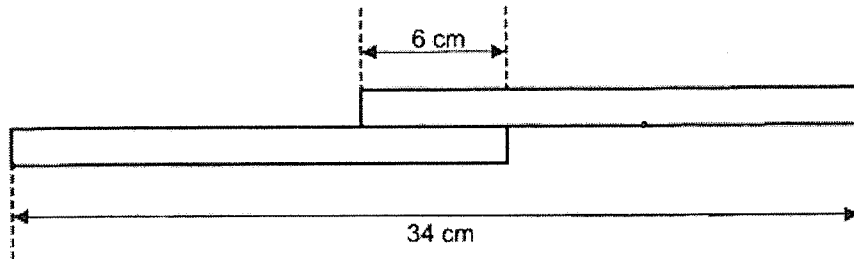

Ans: _____ cm

- 40 Rachel had some cookies. She gave $\frac{5}{8}$ of them to her grandmother and 7 cookies to her aunt. She then had 20 cookies left. How many cookies did she have at first?

Ans: _____

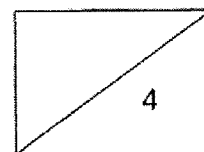

Questions 41 to 45 carry 4 marks each. Show your working clearly in the space below each question and write your answers in the spaces provided.

(20 marks)

- 41 (a) AB and BC are 2 sides of a square. Draw and label the square ABCD in the grid. [2]
- (b) The area of rectangle CEFG is twice the area of the square ABCD. In the grid, draw and label rectangle CEFG. [2]

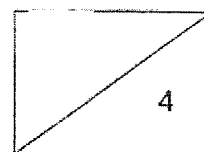
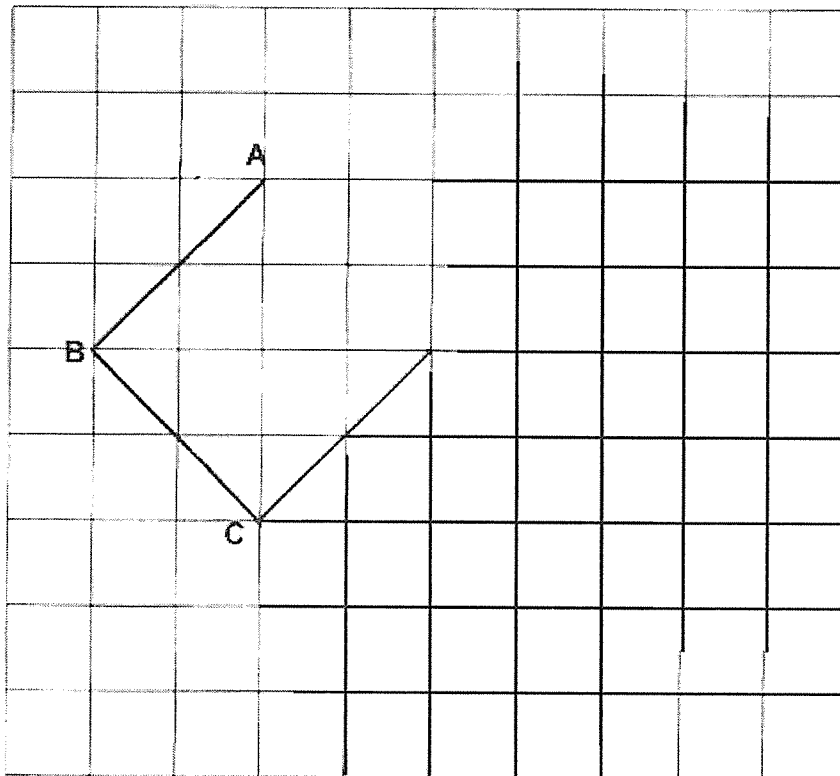

- 42 Rectangle ABCD is made up of 3 identical small rectangles and 2 identical squares. The area of ABCD is 648 cm^2 .

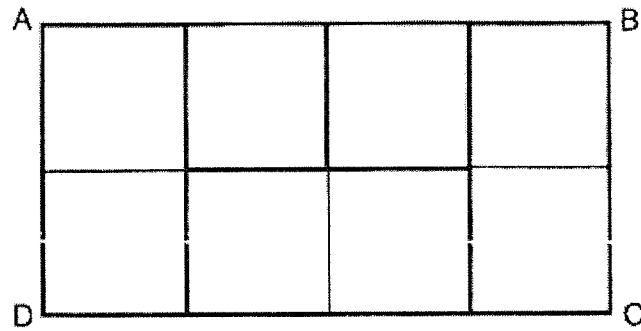

- (a) Find the area of each square.

Ans: (a) _____ [2]

- (b) Find the perimeter of each small rectangle.

Ans: (b) _____ [2]

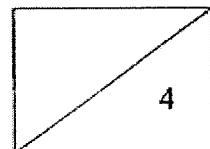

- 43 Mdm Devi bought a dress, a shirt and a bag. She spent the same amount of money on the bag and the dress. The shirt cost \$49.80 less than the bag. The dress cost 3 times as much as the shirt.

(a) What was the cost of the shirt?

Ans: (a) _____ [2]

(b) What was the total cost of the dress and the bag?

Ans: (b) _____ [2]

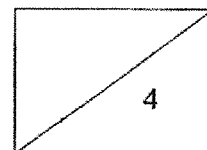

- 44 Aisha and Bella had 219 stickers.
After Aisha used $\frac{1}{3}$ of her stickers and Bella used 39 stickers, they had the same number of stickers left.
How many stickers did Bella have at first?

Ans: _____ [4]

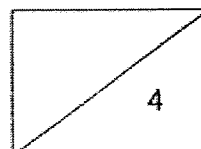

45 The first 18 numbers of a number pattern are given below.

4, 6, 5, 6, 2, 1, 4, 6, 5, 6, 2, 1, 4, 6, 5, 6, 2, 1, ...

1st

7th

13th

(a) What is the 51st number?

Ans: (a) _____ [2]

(b) What is the sum of the first 61 numbers?

Ans: (b) _____ [2]

End of Paper

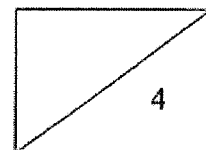

SCHOOL : RED SWASTIKA PRIMARY SCHOOL

LEVEL : PRIMARY 4

SUBJECT : MATH

TERM : SA2 2023

Q1	Q2	Q3	Q4	Q5	Q6	Q7	Q8	Q9	Q10
3	3	4	3	1	4	1	4	2	4
Q11	Q12	Q13	Q14	Q15	Q16	Q17	Q18	Q19	Q20
3	2	2	4	2	1	4	1	1	3

21)	973, 937, 397, 379
22)	12870
23)	$3\frac{3}{6}$
24)	$\frac{3}{6}$
25)	13
26)	50.80
27)	63°
28)	0.33
29)	8 and 16
30)	$145 \times 7 = 1015$ $1015 + 6 = 1021$
31)	$175 - 23 = 152$ $152 \div 2 = 76$

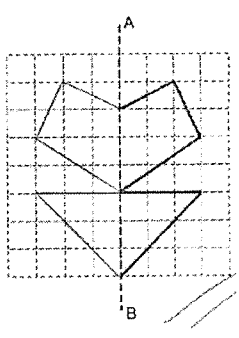
32)	24
33)	$2 \text{ unit} = 20.16$ $1 \text{ unit} = 20.16 \div 2 = 10.08$ $5 \text{ units} = 10.08 \times 5 = 50.4\text{L}$
34)	$9 \times 4 = 36 \text{ cm}$
35)	$6 + 4 = 10$ $10 + 8 = 18$ $18 \times 6 = 108 \text{ cm}^2$
36)	
37)	E
38)	20
39)	$34 - 6 = 28$ $28 \div 2 = 14$ $14 + 6 = 20 \text{ cm}$
40)	$8/8 - 5/8 = 3/8$ $3 \text{ units} = 20 + 7 = 27$ $1 \text{ unit} = 27 \div 3 = 9$ $8 \text{ units} = 8 \times 9 = 72$

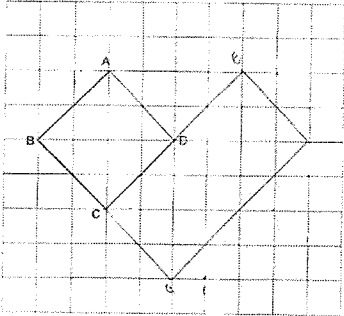
41)	
42)	<p>a) $648\text{cm}^2 \div 8 = 81\text{ cm}^2$ <i>Each square is 81 cm^2</i></p> <p>b) $9\text{cm} \times 9\text{cm} = 81\text{ cm}^2$ <i>1 length of the small square is 9cm</i> $9\text{ cm} \times 6 = 54\text{cm}$</p>
43)	<p>a) $\\$49.80 \div 2 = \\24.90 b) $\\$24.90 + \\$49.80 = \\$74.70$ $\\$74.70 \times 2 = \\149.40</p>
44)	<p>$219 - 39 = 180$ $180 \div 5 = 36$ $36 \times 2 = 72$ $72 + 39 = 111$</p>
45)	<p>a) 5 b) 244 ..</p>

